



QUICKSWITCH® PRODUCTS HIGH-SPEED CMOS 10-BIT BUS EXCHANGE SWITCH

IDTQS3383

FEATURES:

- Enhanced N channel FET with no inherent diode to Vcc
- 5Ω bidirectional switches connect inputs to outputs
- Zero propagation delay, zero added ground bounce
- Undershoot clamp diodes on all switch and control inputs
- Bus exchange allows nibble swap
- Available in QSOP package

APPLICATIONS:

- Hot-swapping, hot-docking
- Voltage translation (5V to 3.3V)
- Resource sharing
- Crossbar switching

DESCRIPTION:

The QS3383 provides ten high-speed CMOS TTL-compatible bus switches. The low ON resistance of the QS3383 allows inputs to be connected to outputs without adding propagation delay and without generating additional ground bounce noise. The Bus Enable (\overline{BE}) signal turns the switches on. The Bus Exchange (BX) signal provides nibble swap of the AB and CD pairs of signals. This exchange configuration allows byte swapping of buses in systems. It can also be used as a 5-wide 2-to-1 multiplexer and to create low delay barrel shifters, etc.

The QS3383 is characterized for operation at -40°C to +85°C.

FUNCTIONAL BLOCK DIAGRAM

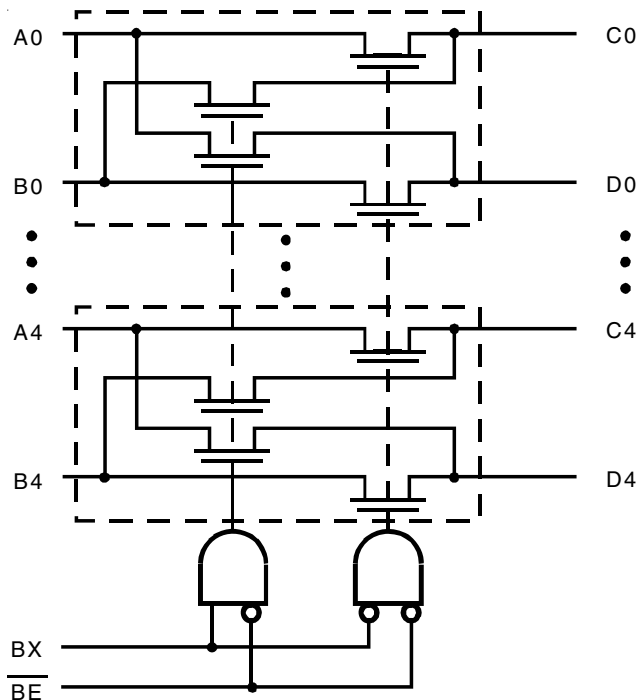

The IDT logo is a registered trademark of Integrated Device Technology, Inc.

INDUSTRIAL TEMPERATURE RANGE

FEBRUARY 2009

PIN CONFIGURATION

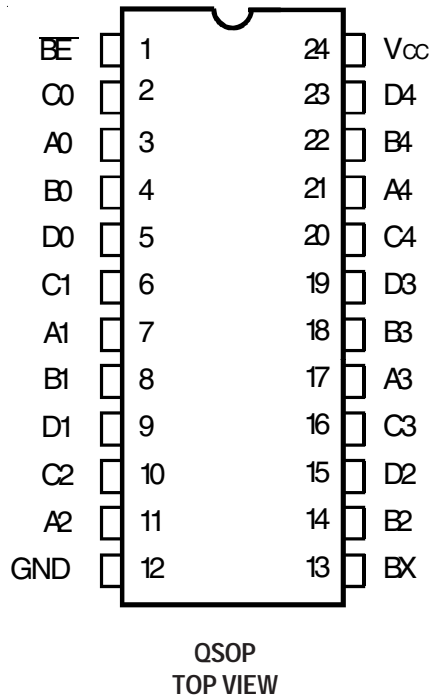

ABSOLUTE MAXIMUM RATINGS⁽¹⁾

Symbol	Description	Max	Unit
VTERM ⁽²⁾	Supply Voltage to Ground	-0.5 to +7	V
VTERM ⁽³⁾	DC Switch Voltage V _s	-0.5 to +7	V
VTERM ⁽³⁾	DC Input Voltage V _{IN}	-0.5 to +7	V
VAC	AC Input Voltage (pulse width ≤20ns)	-3	V
I _{OUT}	DC Output Current	120	mA
P _{MAX}	Maximum Power Dissipation (T _A = 85°C)	0.5	W
T _{STG}	Storage Temperature	-65 to +150	°C

NOTES:

- Stresses greater than those listed under ABSOLUTE MAXIMUM RATINGS may cause permanent damage to the device. This is a stress rating only and functional operation of the device at these or any other conditions above those indicated in the operational sections of this specification is not implied. Exposure to absolute maximum rating conditions for extended periods may affect reliability.
- V_{CC} terminals.
- All terminals except V_{CC}.

CAPACITANCE (T_A = +25°C, f = 1MHz, V_{IN} = 0V, V_{OUT} = 0V)

Pins	Typ.	Max. ⁽¹⁾	Unit
Control Inputs	3	5	pF
Quickswitch Channels (Switch OFF)	5	7	pF

NOTE:

- This parameter is guaranteed but not production tested.

PIN DESCRIPTION

Pin Names	I/O	Description
A0 - A4, B0 - B4	I/O	A and B Buses
C0 - C4, D0 - D4	I/O	C and D Buses
\overline{BE}	I	Bus Switch Enable
BX	I	Bus Exchange

FUNCTION TABLE⁽¹⁾

\overline{BE}	BX	A0 - A4	B0 - B4	Function
H	X	Hi-Z	Hi-Z	Disconnect
L	L	C0 - C4	D0 - D4	Connect
L	H	D0 - D4	C0 - C4	Exchange

NOTE:

- H = HIGH Voltage Level
L = LOW Voltage Level
X = Don't Care
Z = High-Impedance

DC ELECTRICAL CHARACTERISTICS OVER OPERATING RANGE

Following Conditions Apply Unless Otherwise Specified:

Industrial: $T_A = -40^{\circ}\text{C}$ to $+85^{\circ}\text{C}$, $V_{CC} = 5\text{V} \pm 5\%$

Symbol	Parameter	Test Conditions	Min.	Typ. ⁽¹⁾	Max.	Unit
V_{IH}	Input HIGH Voltage	Guaranteed Logic HIGH for Control Pins	2	—	—	V
V_{IL}	Input LOW Voltage	Guaranteed Logic LOW for Control Pins	—	—	0.8	V
I_{IN}	Input Leakage Current (Control Inputs)	$0\text{V} \leq V_{IN} \leq V_{CC}$	—	0.01	± 1	μA
I_{OZ}	Off-State Current (Hi-Z)	$0\text{V} \leq V_{OUT} \leq V_{CC}$, Switches OFF	—	0.01	± 1	μA
RON	Switch ON Resistance ⁽²⁾	$V_{CC} = \text{Min.}, V_{IN} = 0\text{V}, I_{ON} = 30\text{mA}$	—	6	8	Ω
		$V_{CC} = \text{Min.}, V_{IN} = 2.4\text{V}, I_{ON} = 15\text{mA}$	—	12	17	
V_P	Pass Voltage ⁽³⁾	$V_{IN} = V_{CC} = 5\text{V}, I_{OUT} = -5\mu\text{A}$	3.7	4	4.2	V

NOTES:

1. Typical values are at $V_{CC} = 5\text{V}$ and $T_A = 25^{\circ}\text{C}$.
2. R_{ON} is guaranteed but not production tested.
3. Pass voltage is guaranteed but not production tested.

TYPICAL ON RESISTANCE vs V_{IN} AT $V_{CC} = 5\text{V}$

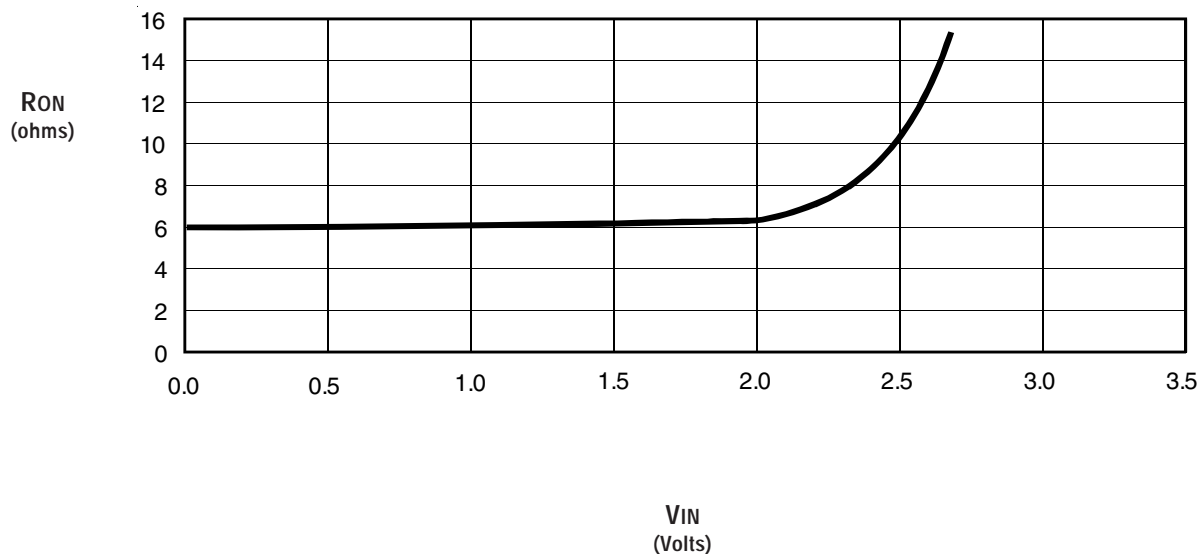

POWER SUPPLY CHARACTERISTICS

Symbol	Parameter	Test Conditions ⁽¹⁾	Max.	Unit
I _{CCQ}	Quiescent Power Supply Current	V _{CC} = Max., V _{IN} = GND or V _{CC} , f = 0	1.5	mA
ΔI _{CC}	Power Supply Current per Input HIGH ⁽²⁾	V _{CC} = Max., V _{IN} = 3.4V, f = 0	2.5	mA
I _{CCD}	Dynamic Power Supply Current per MHz ⁽³⁾	V _{CC} = Max., A and B Pins Open, Control Inputs Toggling @ 50% Duty Cycle	0.25	mA/MHz

NOTES:

- For conditions shown as Min. or Max., use the appropriate values specified under DC Electrical Characteristics.
- Per TTL-driven input (V_{IN} = 3.4V, control inputs only). A, B, C, and D pins do not contribute to ΔI_{CC}.
- This current applies to the control inputs only and represents the current required to switch internal capacitance at the specified frequency. The A and B inputs generate no significant AC or DC currents as they transition. This parameter is guaranteed but not production tested.

SWITCHING CHARACTERISTICS OVER OPERATING RANGE

T_A = -40°C to +85°C, V_{CC} = 5V ± 5%

C_{LOAD} = 50pF, R_{LOAD} = 500Ω unless otherwise noted.

Symbol	Parameter	Min. ⁽¹⁾	Typ.	Max.	Unit
t _{PLH} t _{PHL}	Data Propagation Delay ⁽²⁾ AxBx to CxDx, CxDx to AxBx	—	—	0.25 ⁽³⁾	ns
t _{PZL} t _{PZH}	Switch Turn-On Delay B _E to Ax, Bx, Cx, Dx	1.5	—	6.5	ns
t _{PLZ} t _{PHZ}	Switch Turn-Off Delay ⁽²⁾ B _E to Ax, Bx, Cx, Dx	1.5	—	5.5	ns
t _{BX}	Switch Multiplex Delay Bx to Ax, Bx, Cx, Dx	1.5	—	6.5	ns

NOTES:

- Minimums are guaranteed but not production tested.
- This parameter is guaranteed but not production tested.
- The bus switch contributes no propagation delay other than the RC delay of the ON resistance of the switch and the load capacitance. The time constant for the switch alone is of the order of 0.25ns at C_L = 50pF. Since this time constant is much smaller than the rise and fall times of typical driving signals, it adds very little propagation delay to the system. Propagation delay of the bus switch, when used in a system, is determined by the driving circuit on the driving side of the switch and its interaction with the load on the driven side.

ORDERING INFORMATION

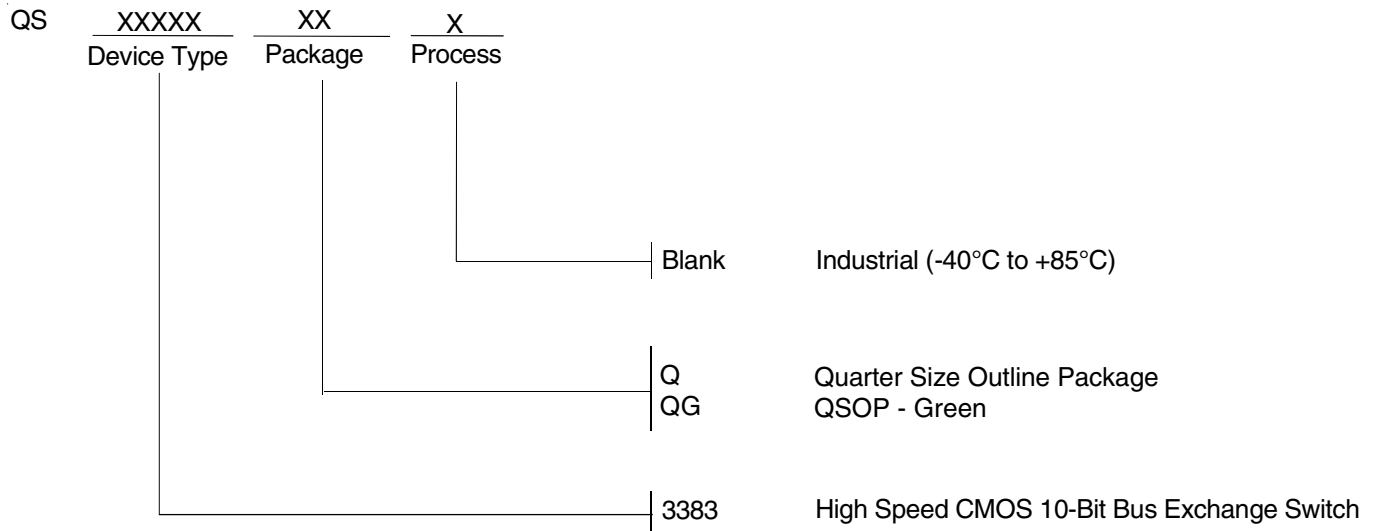

CORPORATE HEADQUARTERS
6024 Silver Creek Valley Road
San Jose, CA 95138

for SALES:
800-345-7015 or 408-284-8200
fax: 408-284-2775
www.idt.com

for Tech Support:
logichelp@idt.com