



TDA2030A

18W Hi-Fi AMPLIFIER AND 35W DRIVER

DESCRIPTION

The TDA2030A is a monolithic IC in Pentawatt[®] package intended for use as low frequency class AB amplifier.

With $V_{S \max} = 44V$ it is particularly suited for more reliable applications without regulated supply and for 35W driver circuits using low-cost complementary pairs.

The TDA2030A provides high output current and has very low harmonic and cross-over distortion.

Further the device incorporates a short circuit protection system comprising an arrangement for automatically limiting the dissipated power so as to keep the working point of the output transistors within their safe operating area. A conventional thermal shut-down system is also included.

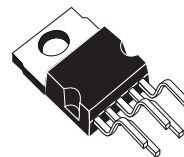

PENTAWATT

ORDERING NUMBERS : TDA2030AH
TDA2030AV

TYPICAL APPLICATION

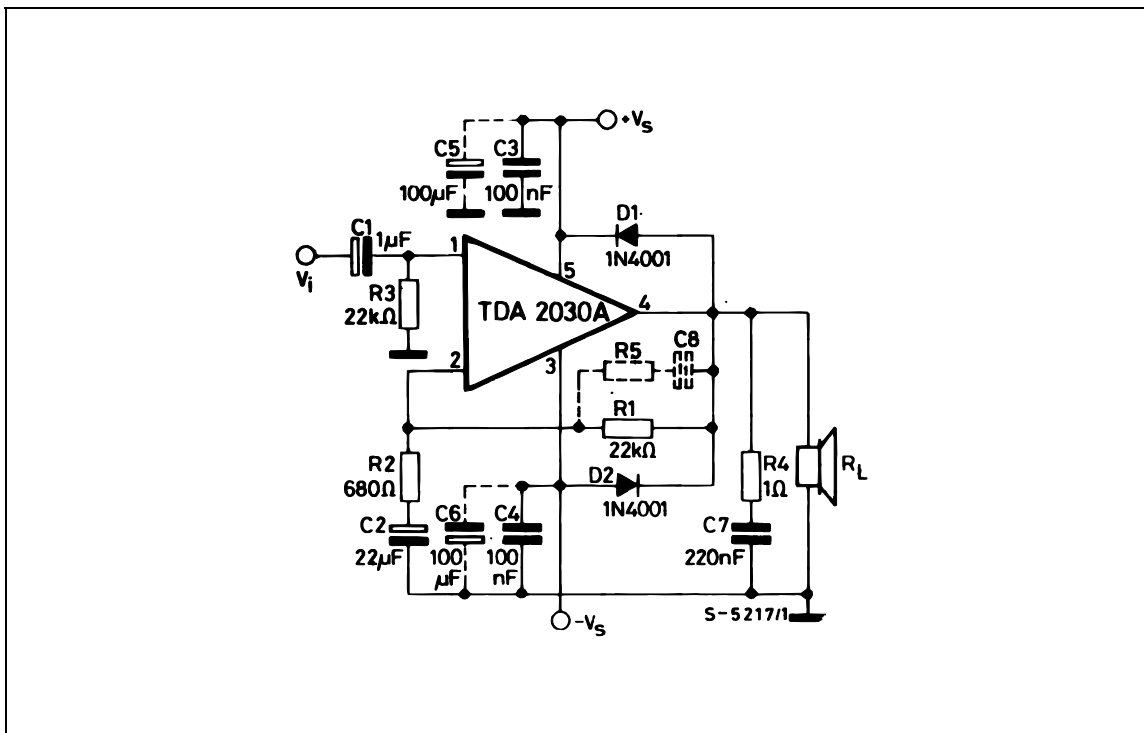

TDA2030A

PIN CONNECTION (Top view)

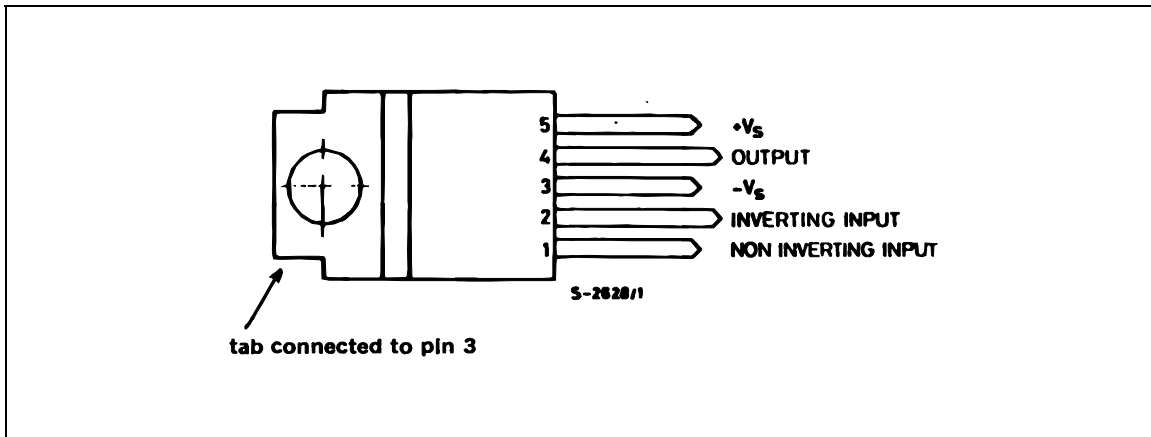

TEST CIRCUIT

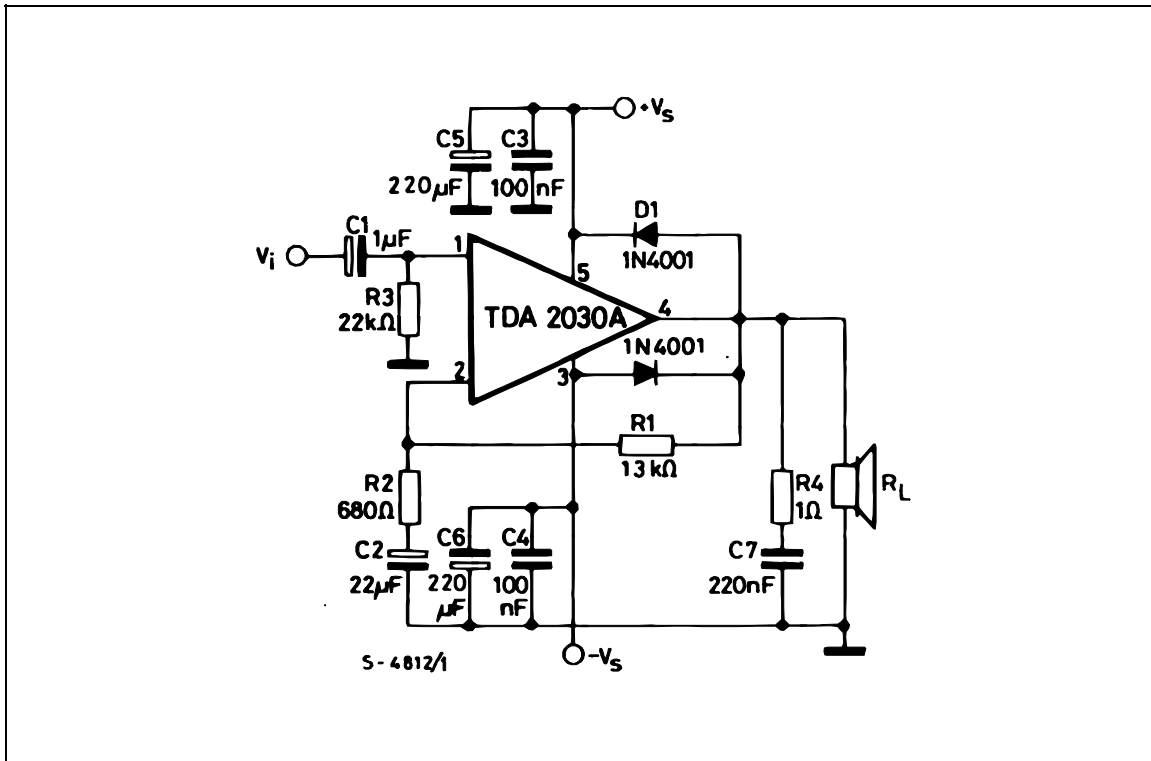

THERMAL DATA

Symbol	Parameter	Value	Unit
$R_{th(j-case)}$	Thermal Resistance Junction-case	Max 3	$^{\circ}C/W$

ABSOLUTE MAXIMUM RATINGS

Symbol	Parameter	Value	Unit
V_s	Supply Voltage	± 22	V
V_i	Input Voltage	V_s	
V_i	Differential Input Voltage	± 15	V
I_o	Peak Output Current (internally limited)	3.5	A
P_{tot}	Total Power Dissipation at $T_{case} = 90\text{ }^\circ\text{C}$	20	W
T_{stg}, T_j	Storage and Junction Temperature	- 40 to + 150	$^\circ\text{C}$

ELECTRICAL CHARACTERISTICS(Refer to the test circuit, $V_s = \pm 16\text{V}$, $T_{amb} = 25\text{ }^\circ\text{C}$ unless otherwise specified)

Symbol	Parameter	Test Conditions	Min.	Typ.	Max.	Unit
V_s	Supply Voltage		± 6		± 22	V
I_d	Quiescent Drain Current			50	80	mA
I_b	Input Bias Current	$V_s = \pm 22\text{V}$		0.2	2	μA
V_{os}	Input Offset Voltage	$V_s = \pm 22\text{V}$		± 2	± 20	mV
I_{os}	Input Offset Current			± 20	± 200	nA
P_O	Output Power	$d = 0.5\%$, $G_v = 26\text{dB}$ $f = 40$ to 15000Hz $R_L = 4\Omega$ $R_L = 8\Omega$ $V_s = \pm 19\text{V}$ $R_L = 8\Omega$	15 10 13	18 12 16		W
BW	Power Bandwidth	$P_o = 15\text{W}$ $R_L = 4\Omega$		100		kHz
SR	Slew Rate			8		V/ μsec
G_v	Open Loop Voltage Gain	$f = 1\text{kHz}$		80		dB
G_v	Closed Loop Voltage Gain	$f = 1\text{kHz}$	25.5	26	26.5	dB
d	Total Harmonic Distortion	$P_o = 0.1$ to 14W $R_L = 4\Omega$ $f = 40$ to $15\text{ }000\text{Hz}$ $f = 1\text{kHz}$ $P_o = 0.1$ to 9W , $f = 40$ to $15\text{ }000\text{Hz}$ $R_L = 8\Omega$		0.08 0.03 0.5		% % %
d_2	Second Order CCIF Intermodulation Distortion	$P_o = 4\text{W}$, $f_2 - f_1 = 1\text{kHz}$, $R_L = 4\Omega$		0.03		%
d_3	Third Order CCIF Intermodulation Distortion	$f_1 = 14\text{kHz}$, $f_2 = 15\text{kHz}$ $2f_1 - f_2 = 13\text{kHz}$		0.08		%
e_N	Input Noise Voltage	B = Curve A B = 22Hz to 22kHz		2 3	10	μV μV
i_N	Input Noise Current	B = Curve A B = 22Hz to 22kHz		50 80	200	pA pA
S/N	Signal to Noise Ratio	$R_L = 4\Omega$, $R_g = 10\text{k}\Omega$, B = Curve A $P_o = 15\text{W}$ $P_o = 1\text{W}$		106 94		dB dB
R_i	Input Resistance (pin 1)	(open loop) $f = 1\text{kHz}$	0.5	5		M Ω
SVR	Supply Voltage Rejection	$R_L = 4\Omega$, $R_g = 22\text{k}\Omega$ $G_v = 26\text{dB}$, $f = 100\text{ Hz}$		54		dB
T_j	Thermal Shut-down Junction Temperature			145		$^\circ\text{C}$

TYPICAL PERFORMANCE OF THE CIRCUIT OF FIGURE 12

Symbol	Parameter	Test Conditions	Min.	Typ.	Max.	Unit
V_s	Supply Voltage			36	44	V
I_d	Quiescent Drain Current	$V_s = 36V$		50		mA
P_o	Output Power	$d = 0.5\%$, $R_L = 4\Omega$, $f = 40$ z to 15Hz $V_s = 39V$ $V_s = 36V$ $d = 10\%$, $R_L = 4\Omega$, $f = 1kHz$ $V_s = 39V$ $V_s = 36V$		35 28		W W
G_v	Voltage Gain	$f = 1kHz$	19.5	20	20.5	dB
SR	Slew Rate			8		V/ μ sec
d	Total Harmonic Distortion	$P_o = 20W$ $f = 1kHz$ $f = 40Hz$ to 15kHz		0.02 0.05		% %
V_i	Input Sensitivity	$G_v = 20dB$, $f = 1kHz$, $P_o = 20W$, $R_L = 4\Omega$		890		mV
S/N	Signal to Noise Ratio	$R_L = 4\Omega$, $R_g = 10k\Omega$, B = Curve A $P_o = 25W$ $P_o = 4W$		108 100		dB

Figure 14 : Typical Amplifier with Spilt Power Supply

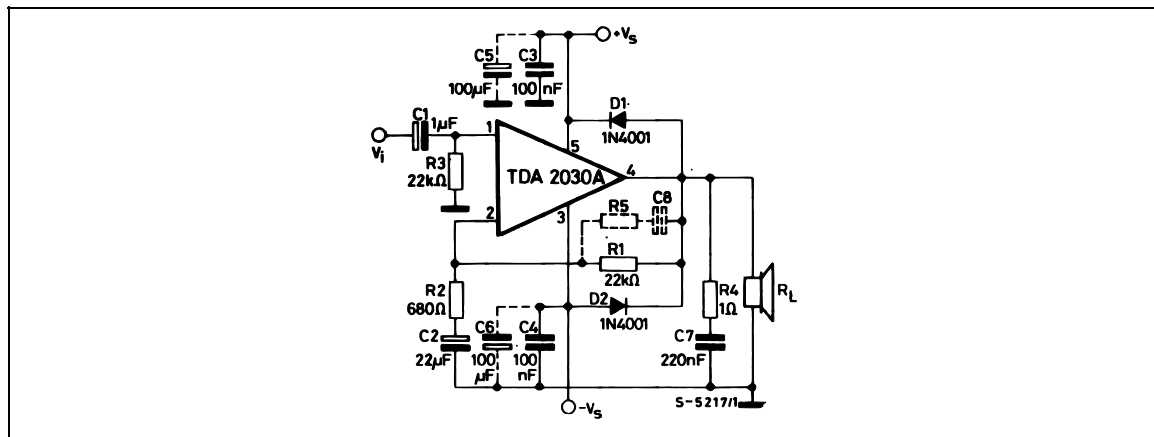
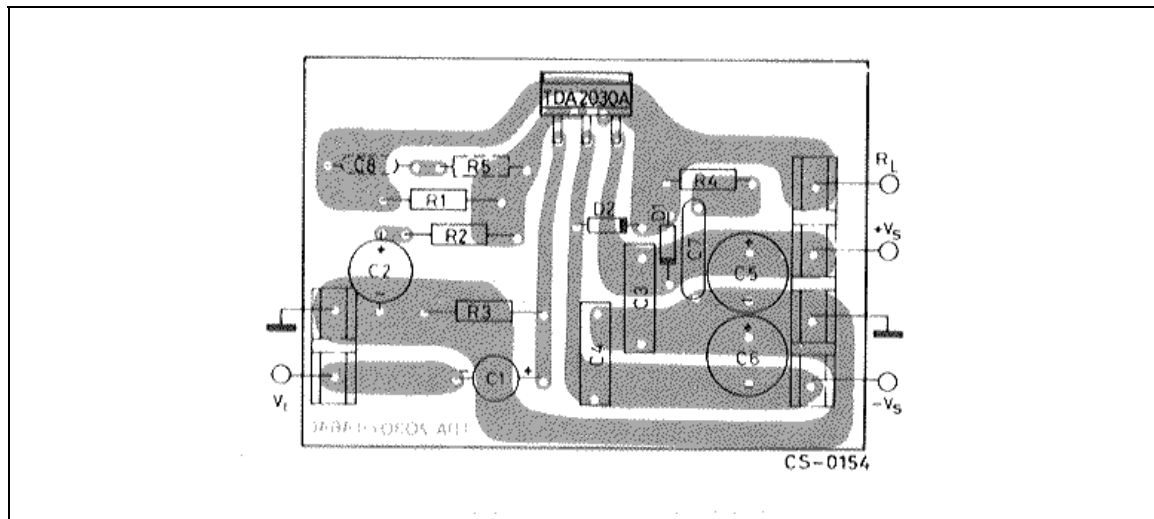

Figure 15 : P.C. Board and Component Layout for the Circuit of Figure 14 (1:1 scale)



DIM.	mm			inch		
	MIN.	TYP.	MAX.	MIN.	TYP.	MAX.
A			4.8			0.189
C			1.37			0.054
D	2.4		2.8	0.094		0.110
D1	1.2		1.35	0.047		0.053
E	0.35		0.55	0.014		0.022
E1	0.76		1.19	0.030		0.047
F	0.8		1.05	0.031		0.041
F1	1.0		1.4	0.039		0.055
G	3.2	3.4	3.6	0.126	0.134	0.142
G1	6.6	6.8	7.0	0.260	0.268	0.276
H2			10.4			0.409
H3	10.05		10.4	0.396		0.409
L	17.55	17.85	18.15	0.691	0.703	0.715
L1	15.55	15.75	15.95	0.612	0.620	0.628
L2	21.2	21.4	21.6	0.831	0.843	0.850
L3	22.3	22.5	22.7	0.878	0.886	0.894
L4			1.29			0.051
L5	2.6		3.0	0.102		0.118
L6	15.1		15.8	0.594		0.622
L7	6.0		6.6	0.236		0.260
L9	2.1		2.7	0.008		0.106
L10	4.3		4.8	0.17		0.189
M	4.23	4.5	4.75	0.167	0.178	0.187
M1	3.75	4.0	4.25	0.148	0.157	0.167
V4	40° (typ.)					
V5	90° (typ.)					
Dia	3.65		3.85	0.144		0.152

OUTLINE AND MECHANICAL DATA

Weight: 2.00gr

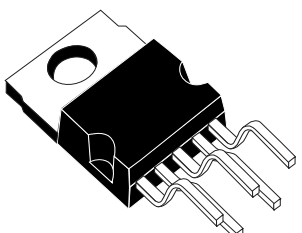

Pentawatt V

