

# Using the High Input Voltage Charger for Single Cell Li-Ion Batteries (KIT34676EPEVBE)

## 1 Purpose

This User Guide helps the Lithium-Ion (Li-Ion) battery charger designer understand the MC34676B and its evaluation board. It illustrates the design procedure when using the MC34676B to design a Li-Ion battery charger, and the way to get the best performance from the MC34676B.

## 2 Scope

The 34676 is a dual 28V input voltage and fully-integrated single cell Li-Ion battery charger, targeting smart handheld applications. One of the inputs is optimized for charging with a USB port, and the second is optimized for an AC/DC adapter power source. The charger has two 28V power devices, to eliminate the need of any external power source selection and input over-voltage protection circuitry. Each of the power devices independently controls the charge current from the input, and performs as an independent charger. Only one of the two chargers operate at a time. The AC charger current and the USB charger current are programmable, up to 1.2A and 400mA, with an external resistor respectively. The voltage across the two external resistors is also used to monitor the actual charge current through each charger respectively. The EOC current of both chargers is the same, and programmable by an external resistor. The 4.85V regulator can be used to power a sub-system directly.

The 34676 has a 5% constant current accuracy for the AC Charger over -40 to 85°C, and a 1.0% constant voltage accuracy over -40 to 85°C. A charge current thermal foldback feature, limits the charge current when the IC internal temperature rises to a preset threshold.

## Contents

1 Purpose.....	1
2 Scope .....	1
3 Application Diagram .....	2
4 Evaluation Board Specification .....	3
5 Component Selection .....	4
6 Layout Design .....	6
7 Evaluation Board Configuration .....	9
8 Test Setup with the Evaluation Board .....	11
9 Bill of Material .....	13
10 References .....	13

### 3 Application Diagram

#### 3.1 Dual-Input Standalone Charger

The MC34676B can be used as a dual-input standalone Li-Ion charger. **Figure 1** is the typical application circuit. Two LEDs indicate the charge status.

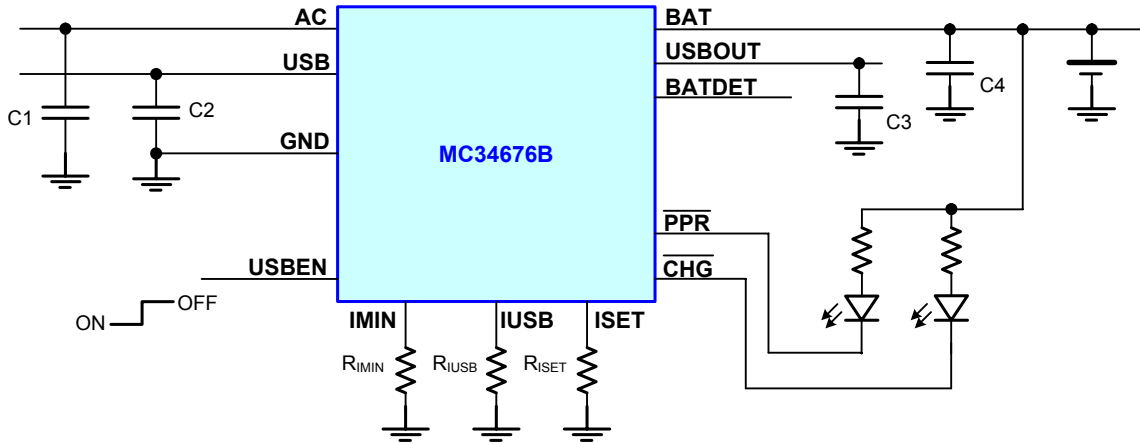

**Figure 1. The dual-input Li-Ion Charger**

#### 3.2 Embedded Charger

When the MC34676B is embedded in the system, the system MCU can control the charger through the USBEN pin and get the charge status through PPR and CHG pins. **Figure 2** is the typical application circuit.

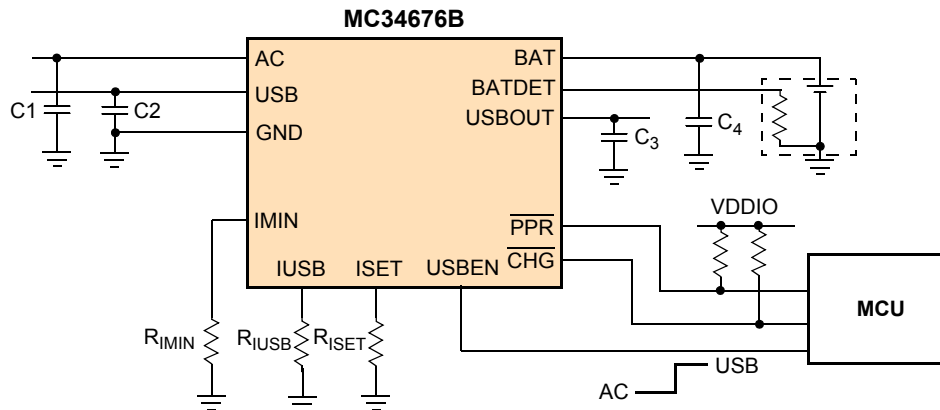

**Figure 2. The Li-Ion Charger Embedded in the Hand Held System**

## 4 Evaluation Board Specification

The evaluation board is designed to work as a standalone charger, or as an embedded charger in a handheld system. **Figure 3** shows its schematic circuit. The normal operation range of the evaluation board is:

For AC charger:

$$V_{AC\_MIN} = 4.3V, V_{AC\_MAX} = 6.8V$$

$$I_{AC\_MAX} = 1200mA$$

For USB charger:

$$V_{USB\_MIN} = 4.3V, V_{USB\_MAX} = 5.85V$$

$$I_{USB\_MAX} = 400mA$$

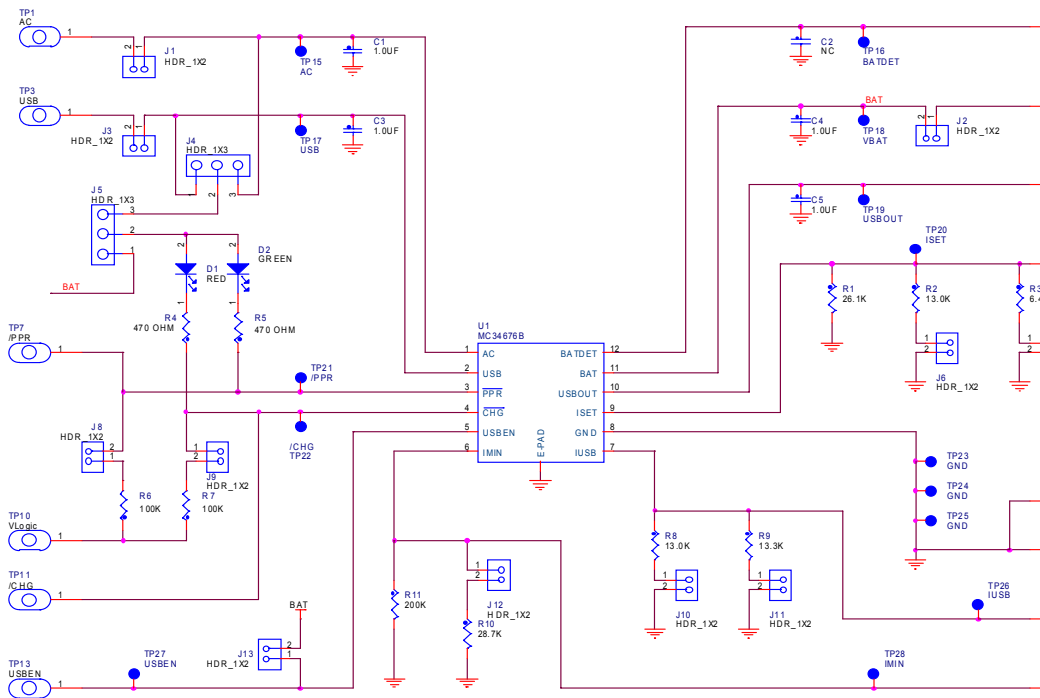

**Figure 3. The Schematic Circuit of the Evaluation Board**

## 5 Component Selection

### 5.1 Input capacitors C1 and C3

The input capacitor is used to minimize the input voltage transient that may cause instability. A ceramic capacitor of 1.0 $\mu$ F or above is required for most applications. X5R and X7R dielectrics have better temperature stability. The evaluation board uses 1.0 $\mu$ F X5R ceramic capacitors. Considering the maximum input voltage rating of the MC34676B is 28V, the input capacitor must have 16V DC rated voltage.

### 5.2 Output capacitors C4 and C5

The charger output capacitor is used for stable operation. An X5R ceramic capacitor minimum of a 1.0 $\mu$ F is required for the charger output. Depending on the load transient current, a larger capacitance may be required. Because the highest output voltage of the MC34676B is 4.2V, a 6.3V DC rated voltage is high enough for the output capacitor.

The regulator output capacitor is used for stable operation, too. An X5R ceramic capacitor minimum of a 1.0 $\mu$ F is required for the regulator output. A 6.3V DC rated voltage is high enough for the regulator output capacitor because the highest output voltage of the output regulator is 5V.

### 5.3 AC CC-mode charge current setting resistors R1, R2, and R3

The resistor between the ISET pin and GND sets the AC CC-mode charge current by the following equation:

$$I_{AC} = \frac{3950}{R_{ISET}} \quad \text{Eqn. 1}$$

where  $R_{ISET}$  is in units of  $\Omega$ ,  $I_{AC}$  is in units of amps. A metal film with a 1% tolerance resistor should be used for temperature stability. As a result, the charge current will be accurate over the whole temperature range.

On the evaluation board, three resistors with two pin header jumpers are used for the user to conveniently configure different charge current values. [Table 1](#) shows the charge current with the different settings of pin headers J6 and J7.

**Table 1. The AC CC-mode Charge Current Settings**

J6	J7	Charge Current
Open	Open	150mA
Short	Open	450mA
Open	Short	750mA
Short	Short	1050mA

### 5.4 USB CC-mode charge current setting resistors R8 and R9

The resistor between the IUSB pin and GND sets the USB CC-mode charge current by the following equation:

$$I_{USB} = \frac{1975}{R_{IUSB}} \quad \text{Eqn. 2}$$

where  $R_{IUSB}$  is in units of  $\Omega$ ,  $I_{USB}$  is in units of amps. A metal film with a 1% tolerance resistor should be used for temperature stability. As a result, the charge current will be accurate over the whole temperature range.

On the evaluation board, two resistors with two pin header jumpers are used for the user to conveniently configure different charge current values. [Table 2](#) shows the charge current with the different settings of pin headers J10 and J11.

**Table 2. The USB CC-mode Charge Current Settings**

J10	J11	Charge Current
-----	-----	----------------

**Table 2. The USB CC-mode Charge Current Settings**

Open	Open	400mA
Short	Open	150mA
Open	Short	150mA
Short	Short	300mA

## 5.5 End-of-charge current setting resistors R10 and R11

The end-of-charge (EOC) current for both the AC charger and the USB charger can be set by the resistors R10 and R11.

On the evaluation board, two resistors with one pin header jumper are used for the user to conveniently configure different EOC current values. **Table 3** shows the EOC current with the different settings of pin header J12.

**Table 3. The EOC Current Settings**

J12	Charge Current
Open	10mA
Short	80mA

## 6 Layout Design

### 6.1 Layout

The KIT34676EPEVBE PCB board has two copper layers. The component side of the KIT34676EPEVBE is provided to locate all components. **Figure 4** is an overview of the board, followed by the layout of each layer.

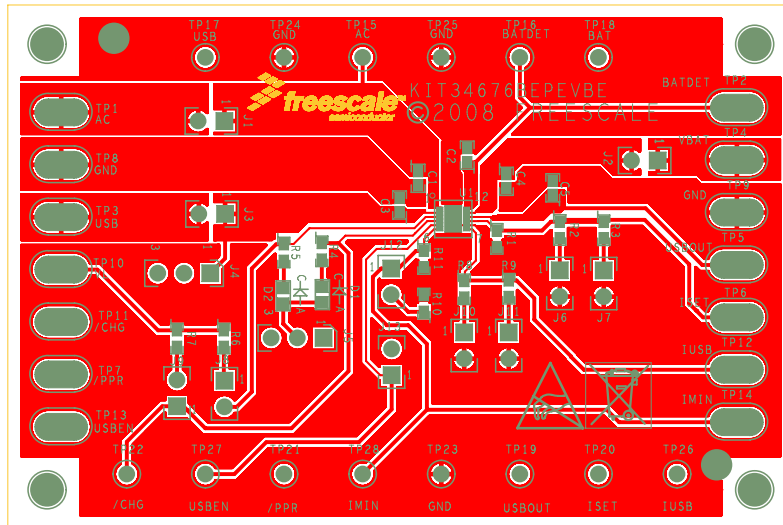

**Figure 4. The Overview of the Evaluation Board**

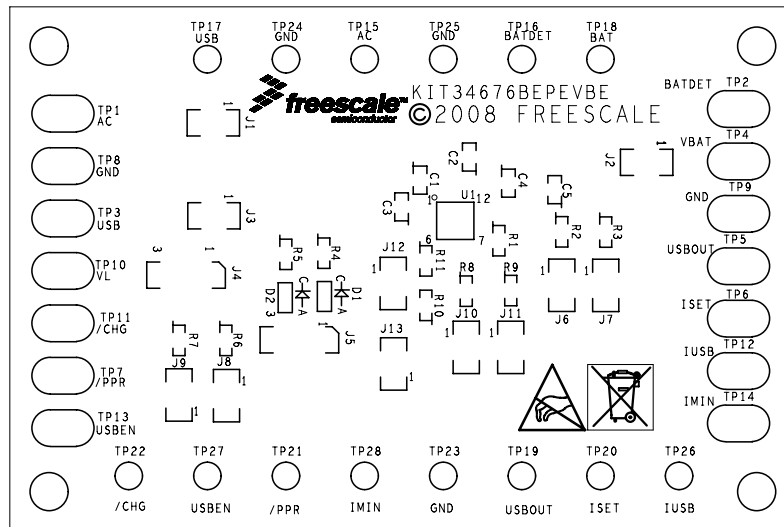

**Figure 5. The Component Side Silkscreen Layer of the Evaluation Board**

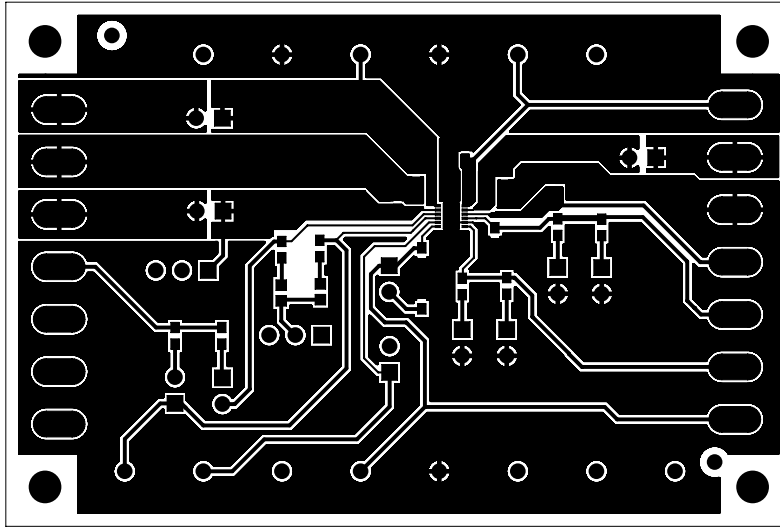

Figure 6. The Component Side Layer of the Evaluation Board

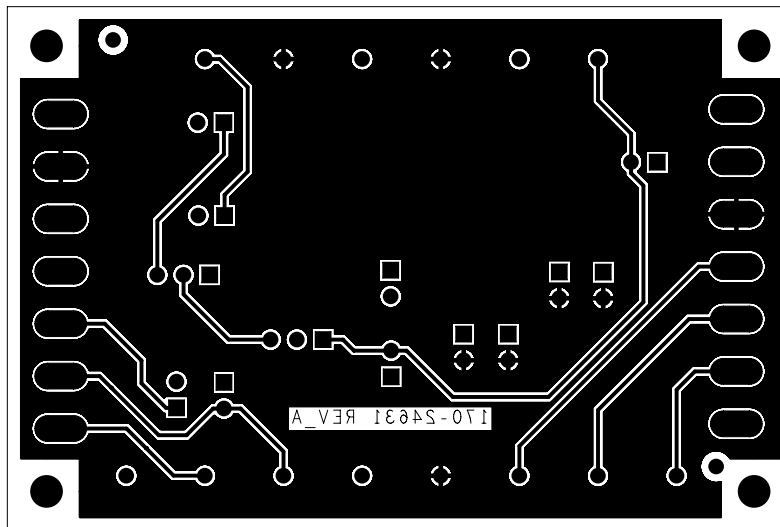

Figure 7. The Solder Side Layer of the Evaluation Board

### 6.2 Layout considerations

- Place decoupling capacitors C1, C3 and C4 as close as possible to the AC pin, USB pin and BAT pin respectively.
- Place the charge current setting resistor as close as possible to the current setting pin to minimize the parasitic capacitance between the current setting pin and ground.
- Use wide traces to connect input power source to the AC pin and USB pin, and BAT pin to the battery.
- To get better thermal performance, put the EPAD pin of the MC34676B on a large ground plane on the component side, and use a via array to connect the EPAD pin to the ground layer, or the large ground plane on the other layer.



## 7 Evaluation Board Configuration

### 7.1 Pin Headers

The J1 and J3 pin headers link the external power source to the AC pin or USB pin of the MC34676B respectively. It allows the user to measure the current from the power source to the evaluation board when using a current meter between pin 1 and pin 2 of J1 or J3. The default setting of the two pin headers is to short pins 1 and 2 of J1, and open pins 1 and 2 of J3.

The J2 pin header links the BAT pin and the external battery connector. It allows the user to measure the charging current from the MC34676B into the battery with a current meter between pin 1 and pin 2. The default setting is to short pins 1 and 2.

The J4 and J5 pin headers select the voltage to supply the D1 and D2 LED indicator. Shorting pins 2 and 3 of J4 and pins 2 and 3 of J5 select AC to power the LEDs. Shorting pins 1 and 2 of J4 and pins 2 and 3 of J5 select USB to power the LEDs. Shorting pins 1 and 2 of J5 and let all pins of J4 open select BAT to power the LEDs. The default settings of J4 and J5 are to short pins 2 and 3 of J4 and pins 2 and 3 of J5.

**IMPORTANT: DO NOT APPLY HIGHER THAN A 12V DC INPUT VOLTAGE TO AC OR USB WHEN AC OR USB IS SELECTED TO POWER THE LEDS.**

The absolute maximum voltage at the  $\overline{\text{PPR}}$  pin and  $\overline{\text{CHG}}$  pin is 12V. When applying higher than a 12V input voltage, select BAT to power the LEDs.

J6 and J7 set the AC CC-mode charge current. The current values related to J6 and J7 settings are shown in [Table 1](#).

J8 and J9 are used to let the user supply an I/O logic voltage to the  $\overline{\text{PPR}}$  pin and the  $\overline{\text{CHG}}$  pin, so the system can interface the  $\overline{\text{PPR}}$  and  $\overline{\text{CHG}}$  signals with the same voltage level. When using LEDs to indicate the charging status, leave J8 and J9 open. When interfacing the  $\overline{\text{PPR}}$  and  $\overline{\text{CHG}}$  signals to the system, short pins 1 and 2 of J8 and J9 and leave J5 open.

J10 and J11 set the USB CC-mode charge current. The current values related to J10 and J11 settings are shown in [Table 2](#).

J12 sets the end-of-charge (EOC) current. The current values related to J12 settings are shown in [Table 3](#).

The J13 pin header allows the user to choose the AC charger when leaving it open, the USB charger is chosen when shorting pins 1 and 2.

The default settings of the evaluation board are shown in [Table 4](#), which selects the AC charger of MC34676B.

**Table 4. The Default Settings of the Pin Headers**

Pin Header Jumpers	Default Setting
J1	Shorted
J2	Shorted
J3	Open
J4	2-3 shorted
J5	2-3 shorted
J6	Shorted
J7	Shorted
J8	Open
J9	Open
J10	Open

**Table 4. The Default Settings of the Pin Headers**

J11	Open
J12	Shorted
J13	Open

## 7.2 Connector Pads

There are 14 connecting pads (TP1 to TP14 with corresponding names) on the evaluation board to let the user simply connect the board to their system. The GND pads link power ground of the MC34676B. The AC pad or USB pad connect an external power source to the evaluation board. The PPR, CHG, USBEN, BATDET, USBOUT, ISET, IUSB and the IMIN pads link to the corresponding pins of the MC34676B. The VL pad is for the user to supply a logic I/O voltage to the evaluation board, if that application system needs a logic voltage level to interface to the PPR and CHG pins of the MC34676B. The VBAT pad connects the positive pole of the Li+ battery being charged.

## 7.3 Test Points

The KIT34676EPEVBE evaluation board provides 11 signal test points and 3 ground test points for users to conveniently hook up multi-meters and oscilloscope probes to evaluate the MC34676B. The test points connect the pins of the MC34676B with the same names directly.

## 8 Test Setup with the Evaluation Board

The test setup is shown in **Figure 8** and **Figure 9**. Connect a DC power source with a larger than 2.0A current limit to the AC pad or a USB power port to the USB pad on the evaluation board. Connect the positive and negative polarities of the Li+ battery to the VBAT pad and the GND pad on the evaluation board respectively. Use a current meter and a voltage meter to measure the charge current and the voltage respectively. Turn on the power supply and let the  $V_{BATDET}$  is less than 1.75V to enable the MC34676B, then the evaluation board starts charging the battery.

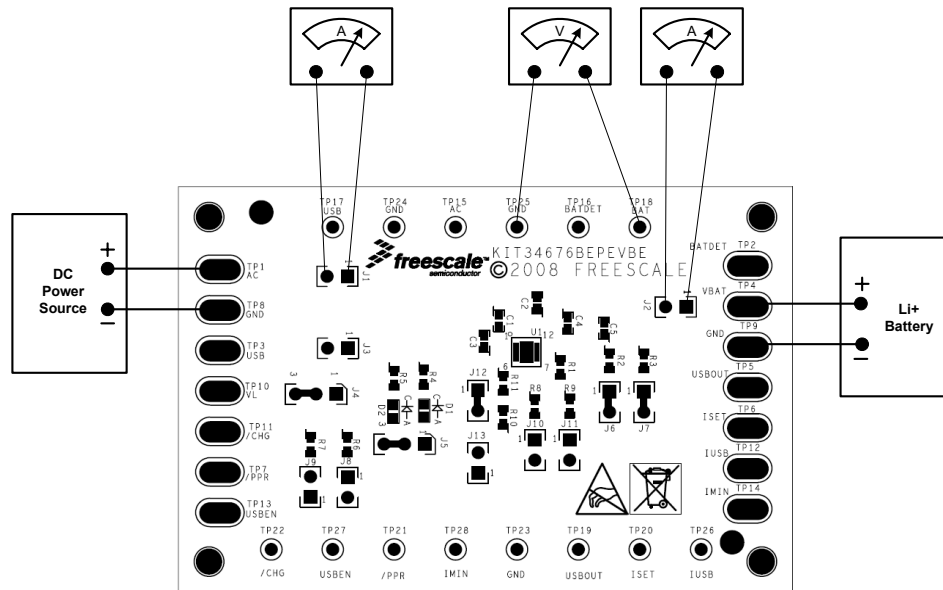

Figure 8. The AC Charger Set Up for the Evaluation Board

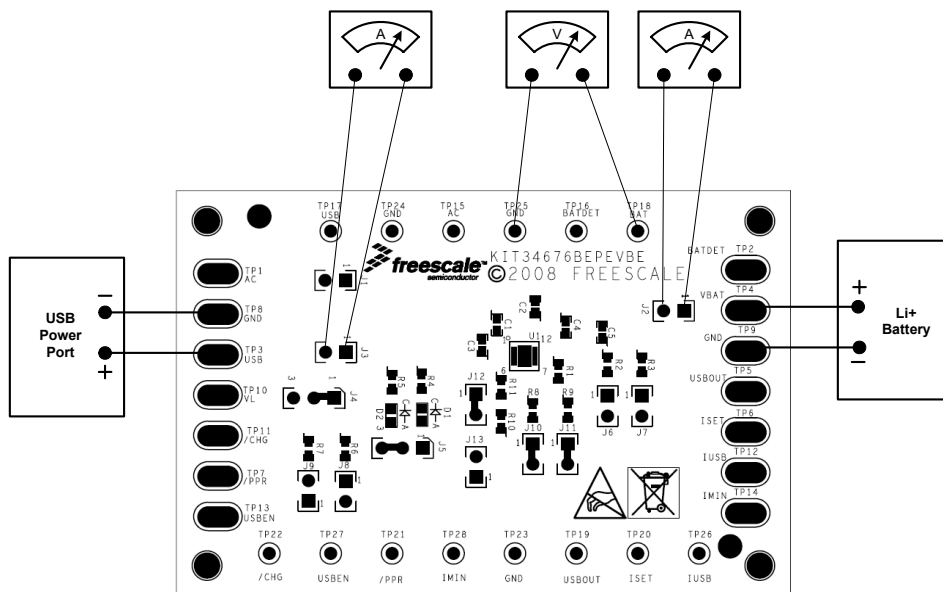

Figure 9. The USB Charger Set Up for the Evaluation Board

## 9 Bill of Material

Item	Qty	Part Reference	Value	DESCRIPTION	Footprint	Mfr	PN
1	2	C1,C3	1.0UF	CAP CER 1.0UF 16V 10% X5R 0603	CC0603	MURATA TDK	GRM188R61C105KA93 C1608X5R1C105K
2	1	C2	NC	No Connection	CC0603	N/A	N/A
3	2	C4,C5	1.0UF	CAP CER 1.0UF 10V 10% X5R 0603 CAP CER 1.0UF 6.3V 10% X5R 0603	CC0603	MURATA TDK	GRM188R61C105KA61 C1608X5R0J105K
4	1	D1	RED	LED ULTA BRIGHT RED 30MA 5V SMT 0603	LED_0603_ C1	LITE ON	LTST-C190KRKT
5	1	D2	GREEN	LED ULTRA-BRIGHT GREEN SMT 0603	LED_0603_ C1	LITE ON	LTST-C190KGKT
6	11	J1,J2,J3,J6, J7,J8,J9,J10 ,J11,J12,J13	HDR_1X2	HDR 1X2 TH 100MIL SP 375H AU	HDR102	TYCO ELEC- TRONICS	826629-2
7	2	J4,J5	HDR_1X3	HDR 1X3 TH 100MIL SP 374.01H AU	HDR103	TYCO ELEC- TRONICS	826629-3
8	1	R1	26.1K	RES MF 26.1K 1/10W 1% 0603	RC0603	KOA SPEER	RK73H1JTDD2612F
9	2	R2,R8	13.0K	RES MF 13.0K 1/10W 1% 0603	RC0603	KOA SPEER	RK73H1JTDD1302F
10	1	R3	6.49K	RES MF 6.49K 1/10W 1% 0603	RC0603	KOA SPEER	RK73H1JTDD6491F
11	2	R4,R5	470 OHM	RES TF 470 1/10W 5% RC0603	RC0603	BOURNS	CR0603JW471E
12	2	R6,R7	100K	RES MF 100K 1/10W 5% 0603	RC0603	BOURNS	CR0603-JW-104ELF
13	1	R9	13.3K	RES MF 13.3K 1/10W 1% 0603	RC0603	KOA SPEER	RK73H1JTDD1332F
14	1	R10	28.7K	RES MF 28.7K 1/10W 1% 0603	RC0603	KOA SPEER	RK73H1JTDD2872F
15	1	R11	200K	RES MF 200K 1/10W 1% 0603	RC0603	KOA SPEER	RK73H1JTDD2003F
16	14	TP1,TP2,TP 3,TP4,TP5,T P6,TP7,TP8, TP9,TP10,T P11,TP12,T P13,TP14	TEST PAD	PCB PAD OVAL DOUBLE SIDE WITH THRU HOLE	200x1000ov	N/A	N/A
17	14	TP15,TP16, TP17,TP18, TP19,TP20, TP21,TP22, TP23,TP24, TP25,TP26, TP27,TP28	TEST POINT	TEST POINT PIN .109 X .087 TH YEL- LOW	TEST_LOO P	COMPONENTS CORPORATION	TP-105-01-00
18	1	U1	MC34676B		3x3 UDFN-12	Freescale	

**\* These are pads only. No component is populated**

Freescale does not assume liability, endorse, or warrant components from external manufacturers that are referenced in circuit drawings or tables. While Freescale offers component recommendations in this configuration, it is the customer's responsibility to validate their application.

## 10 References

Following are URLs where you can obtain information on other Freescale products and application solutions:

Products	Links
Data Sheet MC34676	<a href="http://www.freescale.com/files/analog/doc/data_sheet/MC34676.pdf">www.freescale.com/files/analog/doc/data_sheet/MC34676.pdf</a>
Freescale's Web Site	<a href="http://www.freescale.com">www.freescale.com</a>
Freescale's Analog Web Site	<a href="http://www.freescale.com/analog">www.freescale.com/analog</a>
Freescale's Power Management	<a href="http://www.freescale.com/powermanagement">www.freescale.com/powermanagement</a>

## **How to Reach Us:**

### **Home Page:**

[www.freescale.com](http://www.freescale.com)

### **E-mail:**

[support@freescale.com](mailto:support@freescale.com)

### **USA/Europe or Locations Not Listed:**

Freescale Semiconductor  
Technical Information Center, CH370  
1300 N. Alma School Road  
Chandler, Arizona 85224  
+1-800-521-6274 or +1-480-768-2130  
[support@freescale.com](mailto:support@freescale.com)

### **Europe, Middle East, and Africa:**

Freescale Halbleiter Deutschland GmbH  
Technical Information Center  
Schatzbogen 7  
81829 Muenchen, Germany  
+44 1296 380 456 (English)  
+46 8 52200080 (English)  
+49 89 92103 559 (German)  
+33 1 69 35 48 48 (French)  
[support@freescale.com](mailto:support@freescale.com)

### **Japan:**

Freescale Semiconductor Japan Ltd.  
Headquarters  
ARCO Tower 15F  
1-8-1, Shimo-Meguro, Meguro-ku,  
Tokyo 153-0064  
Japan  
0120 191014 or +81 3 5437 9125  
[support.japan@freescale.com](mailto:support.japan@freescale.com)

### **Asia/Pacific:**

Freescale Semiconductor Hong Kong Ltd.  
Technical Information Center  
2 Dai King Street  
Tai Po Industrial Estate  
Tai Po, N.T., Hong Kong  
+800 2666 8080  
[support.asia@freescale.com](mailto:support.asia@freescale.com)

### **For Literature Requests Only:**

Freescale Semiconductor Literature Distribution Center  
P.O. Box 5405  
Denver, Colorado 80217  
1-800-441-2447 or 303-675-2140  
Fax: 303-675-2150  
[LDCForFreescaleSemiconductor@hibbertgroup.com](mailto:LDCForFreescaleSemiconductor@hibbertgroup.com)

Information in this document is provided solely to enable system and software implementers to use Freescale Semiconductor products. There are no express or implied copyright licenses granted hereunder to design or fabricate any integrated circuits or integrated circuits based on the information in this document.

Freescale Semiconductor reserves the right to make changes without further notice to any products herein. Freescale Semiconductor makes no warranty, representation or guarantee regarding the suitability of its products for any particular purpose, nor does Freescale Semiconductor assume any liability arising out of the application or use of any product or circuit, and specifically disclaims any and all liability, including without limitation consequential or incidental damages. "Typical" parameters that may be provided in Freescale Semiconductor data sheets and/or specifications can and do vary in different applications and actual performance may vary over time. All operating parameters, including "Typicals", must be validated for each customer application by customer's technical experts. Freescale Semiconductor does not convey any license under its patent rights nor the rights of others. Freescale Semiconductor products are not designed, intended, or authorized for use as components in systems intended for surgical implant into the body, or other applications intended to support or sustain life, or for any other application in which the failure of the Freescale Semiconductor product could create a situation where personal injury or death may occur. Should Buyer purchase or use Freescale Semiconductor products for any such unintended or unauthorized application, Buyer shall indemnify and hold Freescale Semiconductor and its officers, employees, subsidiaries, affiliates, and distributors harmless against all claims, costs, damages, and expenses, and reasonable attorney fees arising out of, directly or indirectly, any claim of personal injury or death associated with such unintended or unauthorized use, even if such claim alleges that Freescale Semiconductor was negligent regarding the design or manufacture of the part.

Freescale™ and the Freescale logo are trademarks of Freescale Semiconductor, Inc. All other product or service names are the property of their respective owners.

© Freescale Semiconductor, Inc., 2009. All rights reserved.

KT34676BUG  
Rev. 1.0  
2/2009

