

PRODUCT NUMBER
SEE TABLE

SIDES OF SPRING MAY NOT
EXTEND BEYOND SIDE OF
TERMINAL MORE THAN .004/.10

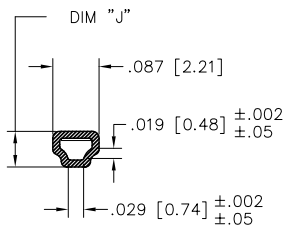

SECTION A-A

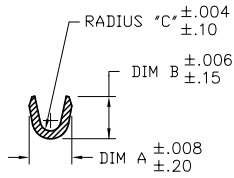

SECTION B-B
(N.T.S.)

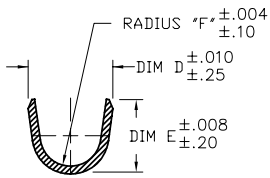

SECTION C-C
(N.T.S.)

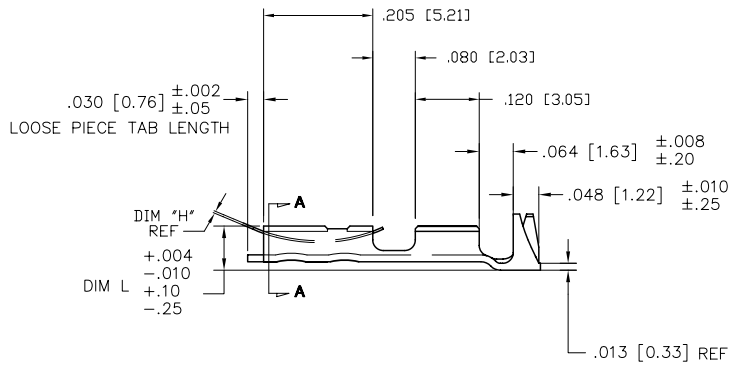
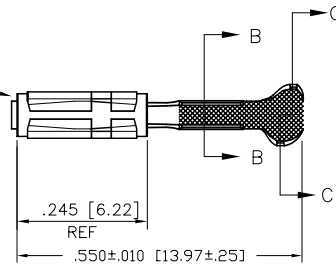

mat'l code SEE TABLE		surface	tolerance	projection	product family	
tolerances unless otherwise specified		angles	linear	INCH/MM	PV TERMINALS	
AA	v08-0113	HTB	2008-03-28	XXX±.01/XX±.3	MAXI PV™ RECEPTACLE CRIMP TO WIRE	
AB	v08-0510	HTB	2008-12-02	XXX±.005/XX±.15 XXXX±.0020/XXX±.051		
V	v05-0468	HTB	2005-05-27	dr	T. BREWBAKER	2006-04-18
W	v06-0218	HTB	2006-03-07	engr	T. BREWBAKER	2006-04-18
X	v06-0303	HTB	2006-04-18	chr	T. BREWBAKER	2006-04-18
Y	v07-0218	HTB	2007-03-16	appd	T. BREWBAKER	2006-04-18
sheet index	revision	AB	AB	AB	FCJ	
	sheet	1	2	3	dwg no	sheet 1 of 3
					46220	A3
					type	Product Customer Drawing

PDM: Rev:AB

STATUS: Released

Printed: Apr 01, 2009

PRODUCT NUMBER			AWG RANGE	MATERIAL AND PLATING		SPRING THICKNESS		BODY			
REEL	LOOSE PC.			BODY : 1/4 HD BRASS	SPRING : BE-CU HEAT TREATED	DIM H		DIM J		DIM L	
						ENGLISH	METRIC	ENGLISH	METRIC	ENGLISH	METRIC
46220-000	46224-000	18-20	OBS.								
46230-000	46234-000	22-26	OBS.	OBSOLETE		OBSOLETE					
46240-000	46244-000	28-32	OBS.	OBSOLETE		OBSOLETE					
46221-000LF	46225-000LF	18-20		40µ"/1.02µm MIN GOLD OVER		0.0058	0.147	0.067	1.70	0.083	2.11
46231-000LF	46235-000LF	22-26		50µ"/1.27µm MIN NICKLE IN		0.0058	0.147	0.067	1.70	0.083	2.11
46241-000	46245-000	28-32	OBS.	OBS. CONTACT AREA (NOTE 4)		OBSOLETE					
46222-000LF	47418-000LF	18-20		75µ"/1.91µm MIN GOLD OVER		0.0075	0.191	0.067	1.70	0.083	2.11
46232-000LF	47419-000LF	22-26		50µ"/1.27µm MIN NICKLE IN		0.0075	0.191	0.067	1.70	0.083	2.11
46242-000	47420-000	28-32	OBS.	OBS. CONTACT AREA (NOTE 4)		OBSOLETE					
46223-000LF	47387-000LF	18-20		40µ"/1.02µm MIN GOLD OVER		0.0075	0.191	0.067	1.70	0.083	2.11
46233-000LF	47384-000LF	22-26		50µ"/1.27µm MIN NICKLE IN		0.0075	0.191	0.067	1.70	0.083	2.11
46243-000	47403-000	28-32	OBS.	OBS. CONTACT AREA (NOTE 4)		OBSOLETE					
46226-000LF	46227-000LF	18-20		40µ"/1.02µm MIN GOLD OVER		0.0048	0.122	0.067	1.70	0.083	2.11
46236-000LF	46237-000LF	22-26		50µ"/1.27µm MIN NICKLE IN		0.0048	0.122	0.067	1.70	0.083	2.11
46246-000	46247-000	28-32	OBS.	OBS. CONTACT AREA (NOTE 4)		OBSOLETE					
46228-000	46229-000	18-20	OBS.	OBSOLETE		OBSOLETE					
46238-000	46239-000	22-26	OBS.	OBSOLETE		OBSOLETE					
46248-000	46249-000	28-32	OBS.	OBSOLETE		OBSOLETE					
46580-000	46581-000	18-20	OBS.	OBSOLETE		OBSOLETE					
46590-000	46591-000	22-26	OBS.	OBSOLETE		OBSOLETE					
46600-000	46601-000	28-32	OBS.	OBSOLETE		OBSOLETE					
47388-000	47391-000	18-20	OBS.	OBSOLETE		OBSOLETE					
47389-000	47392-000	22-26	OBS.	OBSOLETE		OBSOLETE					
47390-000	47393-000	28-32	OBS.	OBSOLETE		OBSOLETE					
47612-000			OBS.	OBSOLETE		OBSOLETE					
47613-000			OBS.	OBSOLETE		OBSOLETE					
47614-000			OBS.	OBSOLETE		OBSOLETE					
47621-000			OBS.	OBSOLETE		OBSOLETE					
47622-000			OBS.	OBSOLETE		OBSOLETE					
47653-000			OBS.	OBSOLETE		OBSOLETE					
47733-000			OBS.	OBSOLETE		OBSOLETE					
47734-000			OBS.	OBSOLETE		OBSOLETE					
47735-000			OBS.	OBSOLETE		OBSOLETE					
47736-000	46582-000	18-20	OBS.	OBSOLETE		OBSOLETE					
47737-000	46592-000	22-26	OBS.	OBSOLETE		OBSOLETE					
47738-000	46602-000	28-32	OBS.	OBSOLETE		OBSOLETE					
48188-000	48189-000	22-26	OBS.	OBSOLETE		OBSOLETE					

SEE SHEET 3 FOR PRODUCTS WITH LEAD-FREE TIN PLATING.

mat'l. code	SEE TABLE	surface	tolerance	projection	product family
tr. ecn no	dr. date	tolerances unless otherwise specified			PV TERMINALS
AB		angles	linear	INCH/MM	title
				scale 1:1	MAXI PV™ RECEPTACLE CRIMP TO WIRE
		dr. T. BREWBAKER 2006-04-18			dwg no
		engr. T. BREWBAKER 2006-04-18			sheet 2 of 3
		chr. T. BREWBAKER 2006-04-18			size
		appd. T. BREWBAKER 2006-04-18			46220
sheet index	revision sheet				A3
					type Product Customer Drawing

PRODUCT NUMBER		AWG RANGE	MATERIAL AND PLATING		SPRING THICKNESS		BODY			
REELED	LOOSE PC.				DIM H		DIM J		DIM L	
			BODY : 1/4 HD BRASS	SPRING : BE-CU HEAT TREATED	ENGLISH	METRIC	ENGLISH	METRIC	ENGLISH	METRIC
46580-000LF	46581-000LF	18-20	HOT DIPPED TIN (NOTE 7)	TIN PLATED	0.0075	0.191	0.067	1.70	0.083	2.11
46590-000LF	46591-000LF	22-26			0.0075	0.191	0.067	1.70	0.083	2.11
46600-000LF	46601-000LF	28-32			0.0075	0.191	0.067	1.70	0.083	2.11
47388-000LF	47391-000LF	18-20	HOT DIPPED TIN (NOTE 7)	TIN PLATED	0.0058	0.147	0.067	1.70	0.083	2.11
47389-000LF	47392-000LF	22-26			0.0058	0.147	0.067	1.70	0.083	2.11
47390-000LF	47393-000LF	28-32			0.0058	0.147	0.067	1.70	0.083	2.11
47736-000LF	46582-000LF	18-20	HOT DIPPED TIN (NOTE 7)	TIN PLATED	0.0048	0.122	0.067	1.70	0.083	2.11
47737-000LF	46592-000LF	22-26			0.0048	0.122	0.067	1.70	0.083	2.11
47738-000LF	46602-000LF	28-32			0.0048	0.122	0.067	1.70	0.083	2.11

AWG RANGE	WIRE BARREL						INSULATION BARREL									
	DIM A		DIM B		DIM C		INSULATION DIA. RANGE FOR DISCRETE TERMINALS		INSULATION DIA. RANGE WHEN USED WITH MAXI LATCH HSG.		DIM D		DIM E		DIM F	
	ENGLISH	METRIC	ENGLISH	METRIC	ENGLISH	METRIC	ENGLISH	METRIC	ENGLISH	METRIC	ENGLISH	METRIC	ENGLISH	METRIC	ENGLISH	METRIC
18-20	0.110	2.79	0.110	2.79	0.021	0.53	0.042 - 0.103	1.07 - 2.62	0.042 - 0.060	1.07 - 1.52	0.139	3.53	0.123	3.12	0.050	1.27
22-26	0.070	1.78	0.070	1.78	0.017	0.43	0.036 - 0.103	0.91 - 2.62	0.036 - 0.060	0.91 - 1.52	0.139	3.53	0.123	3.12	0.050	1.27
28-30	0.054	1.37	0.058	1.47	0.011	0.28	0.028 - 0.054	0.71 - 1.37	0.028 - 0.054	0.71 - 1.37	0.115	2.92	0.110	2.79	0.040	1.02

NOTES:

- FOR DIMENSIONS OF WIRE BARREL AND INSULATION BARREL SEE TABLE.
- PART TO MATE WITH .025±.002 [0.64±0.05] SQ. PIN.
- APPLICABLE SPECIFICATIONS:
 - BUS-12-096 : PRODUCT SPECIFICATION
 - TA-213 : CRIMP SPECIFICATION FOR TERMINALS USED WITH MAXI-LATCH HOUSINGS.
 - TA-356 : CRIMP SPECIFICATION FOR CONTACTS NOT USED IN HOUSINGS.
- FINISH TO BE AS SPECIFIED IN CONTACT AREA. REMAINDER OF TOP OF PART TO BE GOLD FLASH OVER 50µ"/1.27µm NICKEL. BACKSIDE OF TERMINALS PLATED WITH 30µ"/0.76µm NICKEL ONLY.
- PRODUCT MEETS EUROPEAN UNION DIRECTIVES AND OTHER COUNTRY REGULATIONS AS DESCRIBED IN GS-22-008.
- THIS PRODUCT IS NOT INTENDED TO BE EXPOSED TO MANUFACTURING SOLDER PROCESSES.
- THIS PRODUCT HAS 100% TIN PLATING IN THE INTERFACE AND HAS NOT BEEN TESTED FOR WHISKER GROWTH IN ALL INTERCONNECT ENVIRONMENTS.

mat'l. code	surface	tolerance	projection	product family
SEE TABLE	✓			PV TERMINALS
tr. ecn no. dr. date	tolerances unless otherwise specified	angles	linear	title
AB				MAXI PV™ RECEPTACLE CRIMP TO WIRE
				dwg no. sheet 3 of 3 size
				46220 A3
				type Product Customer Drawing
sheet index	revision sheet			