

NUMBER C-1734144

3RD ANGLE PROJECTION

METRIC

PRINT DIST DW DIMENSIONS IN MILLIMETERS. DO NOT SCALE PRINT.

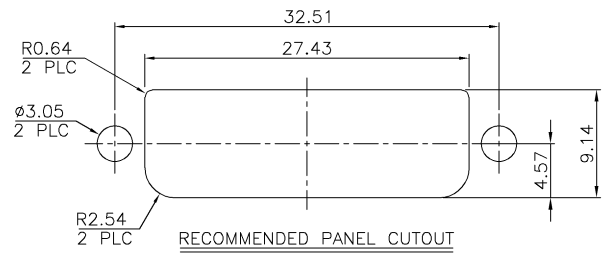
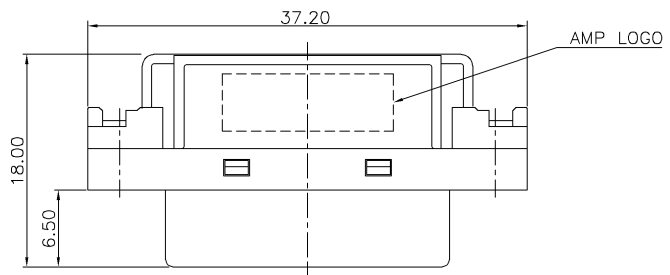

RECOMMENDED PANEL CUTOUT

- NOTES:
- MATERIAL:
HOUSING: THERMOPLASTIC, UL 94V-0 RATED, COLOR: IVORY.
CONTACT: PHOSPHOR BRONZE, THICKNESS=0.3mm.
SHELL: SPOC-SD, THICKNESS=0.5mm.
HOOK: BRASS, THICKNESS=0.5mm.
NUT: BRASS.
 - FINISH:
CONTACT: GOLD PLATED(SEE TABLE) ON CONTACT AREA, 100µ" MIN. BRIGHT TIN PLATED ON SOLDERTAILS, 50µ" MIN. NICKEL UNDERPLATED OVERALL.
SHIELD: 50µ" MIN. NICKEL PLATED.
HOOK: TIN PLATED.
NUT: NICKEL PLATED.
 - #4-40 UNC SCREW, SCREW HEAD LENGTH: 6.0±0.5mm.
SCREW SEPARATELY PACKED.
 - WAVE SOLDER CAPABLE TO 240°C PER TE Connectivity SPEC109-202, CONDITION A.
 - OBsolete PARTS: OBSOLETE CIS STREAMLINING PER D.RENAUD/D.SINISI

W/	GOLD FLASH	2-1734144-1
OBsolete	W/	30u"
W/	10u"	1-1734144-2
W/O	GOLD FLASH	1-1734144-1
W/O	30u"	1734144-3
W/O	10u"	1734144-2
W/O	GOLD FLASH	1734144-1
SCREW	GOLD PLATED	PART NUMBER

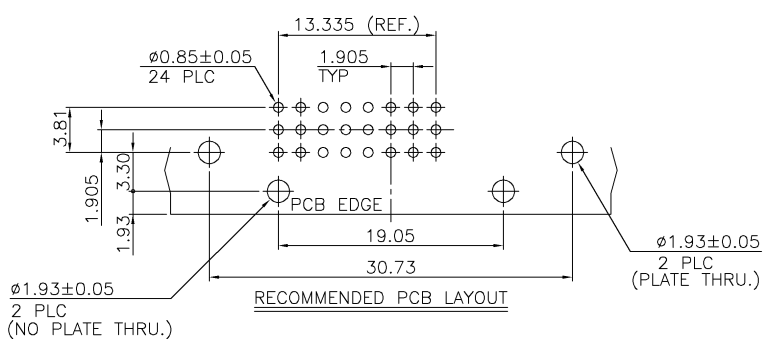
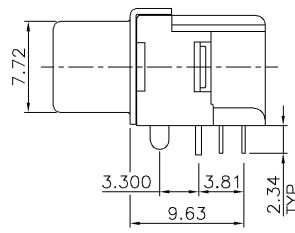
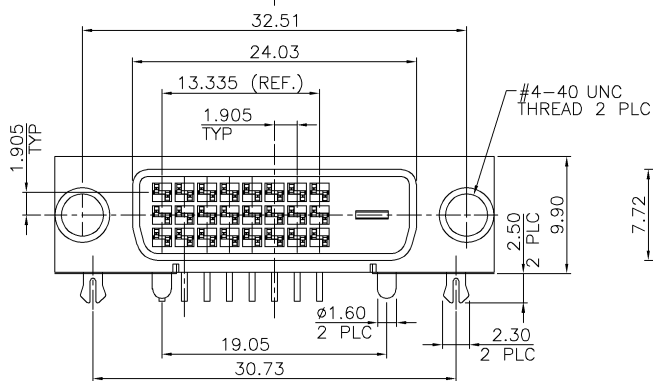

RECOMMENDED PCB LAYOUT

TOLERANCES UNLESS OTHERWISE SPECIFIED:		DWN	O. HU	TE Connectivity
0 PLC ±		08-JUL-2005	S. HOU	NAME
1 PLC ± 0.20		08-JUL-2005	W.J. KE	DVI-D DIGITAL, RCPT. CONN., RIGHT ANGLE
2 PLC ± 0.20		08-JUL-2005	APVD	LOC
3 PLC ± 0.10		08-JUL-2005	PRODUCT SPEC	SIZE
ANGLES ± 3°			108-1941	DRAWING NO
MATERIAL	SEE NOTE			C-1734144
FINISH	SEE NOTE			REV
				P
				SCALE
				1 OF 2

P	REVISION RECORD	REVISED PER ECO-11-005301	RK HMR	DATE
LTR		ECO	DWN	

8 7 6 5 4 3 2 1 CUSTOMER DRAWING

NUMBER
C-1734144

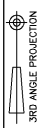

METRIC

PRINT DIST
DW
DIMENSIONS IN MILLIMETERS. DO NOT SCALE PRINT.

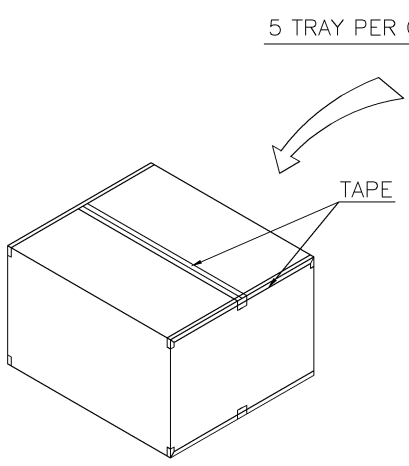
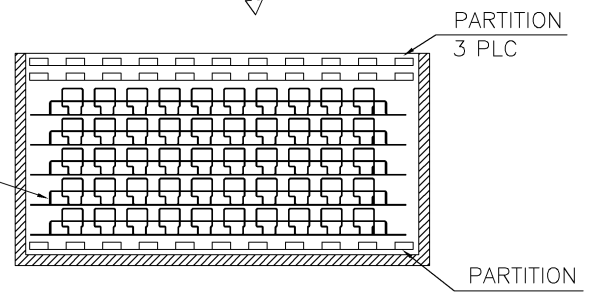
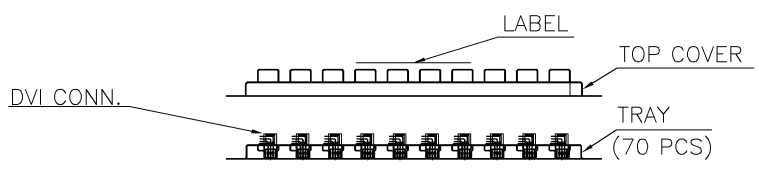

3.55	2.63	340X278X146	340X275X19.6	350
G.W./CARTON	N.W./CARTON	CARTON SIZE	TRAY SIZE	QUANTITY

TOLERANCES UNLESS OTHERWISE SPECIFIED: 0 PLC ± 1 PLC ± 2 PLC ± 3 PLC ± ANGLES ±	DWN	O. HU	STE TE Connectivity
	CHK	S. HOU	
MATERIAL SEE NOTE	APVD	W.J. KE	NAME
	PRODUCT SPEC	08-JUL-2005	DVI-D DIGITAL, RCPT. CONN., RIGHT ANGLE
FINISH SEE NOTE	APPLICATION SPEC	-	LOC
	WEIGHT	-	SIZE
			DRAWING NO
			C-1734144
			REV
			P
			SCALE
			2 OF 2

LTR	REVISION RECORD	SEE SHEET 1.	DWN	CHK	DATE
		ECO			

CUSTOMER DRAWING