

THIS DOCUMENT IS THE PROPERTY OF KEYSTONE ELECTRONICS CORP. AND SHALL NOT BE REPRODUCED, DISTRIBUTED OR USED AS A BASIS FOR MANUFACTURE WITHOUT PRIOR WRITTEN PERMISSION FROM KEYSTONE ELECTRONICS CORP.

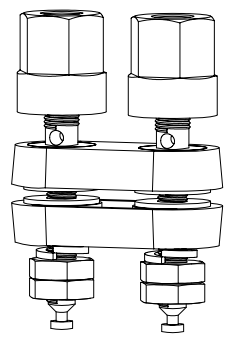
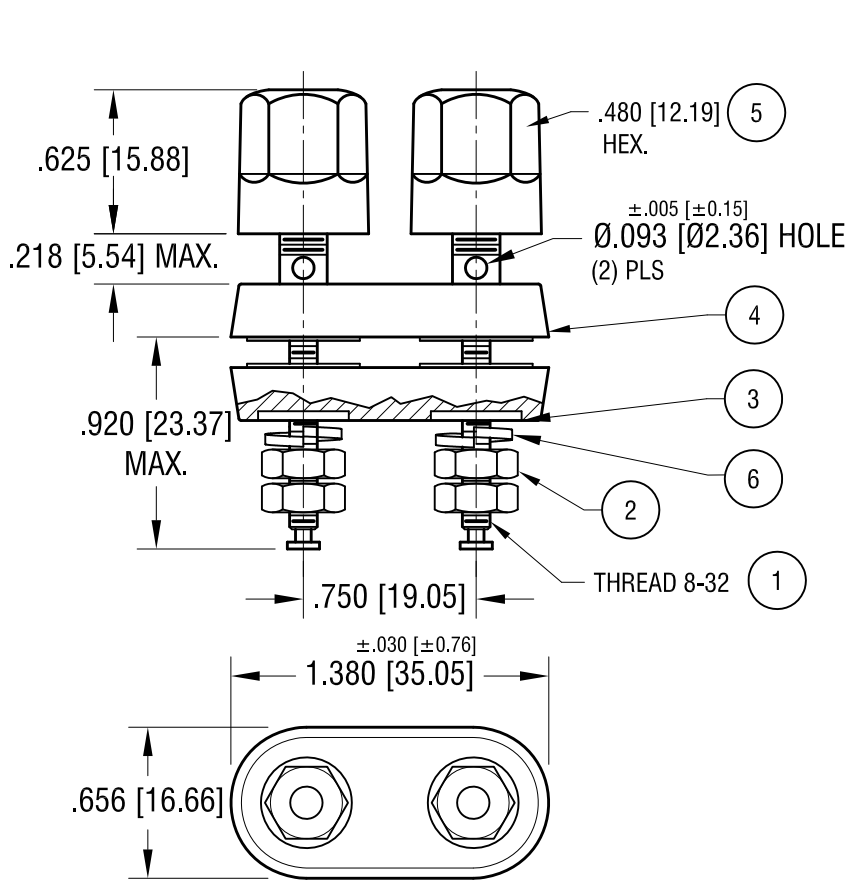

6	2	WASHER, SPLIT	STEEL	GOLD PL.
5	2	HEAD, (1) RED, (1) BLK	NYLON	-
4	2	WASHER, INSULATOR	NYLON	-
3	2	WASHER, INSERT	STEEL	GOLD PL.
2	4	NUT	BRASS	GOLD PL.
1	2	SHAFT	BRASS	GOLD PL.
NO.	QTY	DESCRIPTION	MAT'L	FINISH

KEYSTONE ELECTRONICS CORP.
 www.keyelco.com • ASTORIA, N.Y. 11105-2017 • Tel (718) 956-8900

PART NAME
 STANDARD 'DUAL' BINDING POST

MATERIAL
 AS NOTED

FINISH AS NOTED	DRN BY NT	DATE 2.11.09
	APP'D	SCALE 1.2X

TOLERANCES INCH [MM]
 DECIMAL ±.010 [±0.25]
 ANGULAR ± 1°
 UNLESS OTHERWISE SPECIFIED

CODE
 C/M

DRN BY
 DATE
 SCALE
 DWG NO.

4108

2.11.09	CHANGE AS PER ECN 09-010	B
DATE	DESCRIPTION	REV.