



We Tame Photons to Work for You!



Products > LEDs > Thru-Hole > Round > 3mm > Electrical Features > Low Current



Features / Options

- ▶ State-of-the-Art, High Brightness Chip Technology
- ▶ Choice of Colors and Lens Finishes
- ▶ Lead Frame / Lens Casting Reliability
- ▶ Easy-to-Solder Leads, Tin Finish
- ▶ Available Bulk or on Tape and Reel
- ▶ Lead Trimming and Forming Available
- ▶ Custom Shapes, Easily Tooled, Low Minimum

Applications / Uses

- ▶ Board or Panel Indication or Illumination
- ▶ Annunciator and Control Panels
- ▶ Telecom Switches and Central Station Equipment
- ▶ Large Panel Indicators

Part Number:	Brightness	Dice Material	Emitted Color	Peak Wavelength	Epoxy Lens	Operating Typ Vf (V)	Intensity Typ, mcd @ 20 mA	View Angle 2x Theta		
SSL-LX3044LGD	STANDARD	GaP	Green	565	Diffused	2.1	30	60		—
SSL-LX3044LID	STANDARD	GaAsP	Red	635	Diffused	2	30	60		—
SSL-LX3044LYD	STANDARD	GaAsP	Yellow	585	Diffused	2.1	30	60		—
SSL-LX3054LGD	STANDARD	GaP	Green	565	Diffused	2.1	30	60		—
SSL-LX3054LID	STANDARD	GaAsP	Red	635	Diffused	2	40	60		—
SSL-LX3054LYD	STANDARD	GaAsP	Yellow	585	Diffused	2.1	30	60		—
SSL-LX3064LGD	STANDARD	GaP	Green	565	Diffused	2.1	30	60		—
SSL-LX3064LID	STANDARD	GaAsP	Red	635	Diffused	2	40	60		—
SSL-LX3064LYD	STANDARD	GaAsP	Yellow	585	Diffused	2.1	30	60		—

UNCONTROLLED DOCUMENT

PART NUMBER		REV.
SSL-LX3044LGD		C
REV.	E.C.N. NUMBER AND REVISION COMMENTS	DATE
A	REMOVED FLAT EDGE FROM FLANGE.	4.28.92
B	UPDATED SPECS.	11.28.94
C	E.C.N. #10BRDR. & REDRAWN IN 3D.	4.9.01

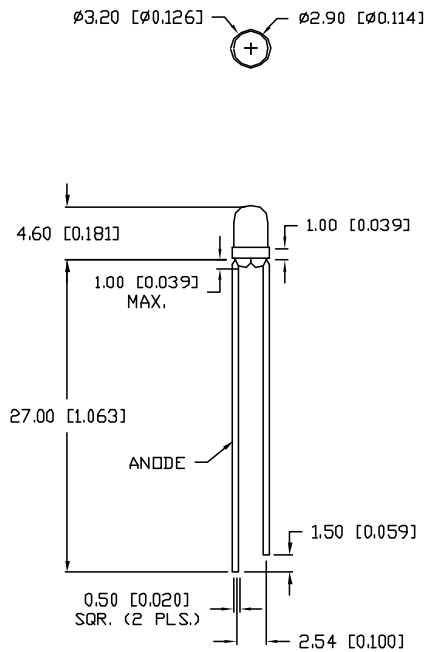

ELECTRO-OPTICAL CHARACTERISTICS $T_A=25^\circ\text{C}$ $I_f=20\text{mA}$

PARAMETER	MIN	TYP	MAX	UNITS	TEST COND
PEAK WAVELENGTH		565		nm	
FORWARD VOLTAGE		2.2	2.6	V_f	
REVERSE VOLTAGE	5.0			V_r	$I_f=100\mu\text{A}$
AXIAL INTENSITY		30		md	$I_f=20\text{mA}$
	1.0			md	$I_f=2\text{mA}$
VIEWING ANGLE		60		2x theta	
EMITTED COLOR:	GREEN				
EPOXY LENS FINISH:	GREEN DIFFUSED				

LIMITS OF SAFE OPERATION AT 25°C

PARAMETER	MAX	UNITS
PEAK FORWARD CURRENT*	150	mA
STEADY CURRENT	25	mA
POWER DISSIPATION	105	mW
DERATE FROM 25°C	-1.6	$\text{mW}/^\circ\text{C}$
OPERATING, STORAGE TEMP.	-40 TO +85	$^\circ\text{C}$
SOLDERING TEMP.	+260	$^\circ\text{C}$
2.0mm FROM BODY		3 SEC. MAX

* $t < 10\mu\text{s}$

UNCONTROLLED DOCUMENT

*UNLESS OTHERWISE SPECIFIED TOLERANCES PER DECIMAL PRECISION ARE: X=±1 (±0.039), XI=±0.5 (±0.020), XIX=±0.25 (±0.010), XXX=±0.127 (±0.005). LEAD SIZE=±0.05 (±0.002), LEAD LENGTH=±0.75 (±0.030). MIN= +DECIMAL PRECISION -0.00 MAX.= +0.00 -DECIMAL PRECISION

REV.	PART NUMBER
C	SSL-LX3044LGD
T-3mm (T-1) 565nm GREEN LED, GREEN DIFFUSED LENS, LOW CURRENT OPERATION.	

CONFIDENTIAL INFORMATION
THE INFORMATION CONTAINED IN THIS DOCUMENT IS THE PROPERTY OF LUMEX INC. EXCEPT AS SPECIFICALLY AUTHORIZED IN WRITING BY LUMEX INC., THE HOLDER OF THIS DOCUMENT SHALL KEEP ALL INFORMATION CONTAINED HEREIN CONFIDENTIAL AND SHALL PROTECT SAME IN WHOLE OR IN PART FROM DISCLOSURE AND DISSEMINATION TO ALL THIRD PARTIES.

RELIABILITY NOTE
OUR MANY YEARS OF EXPERIENCE DATA ACCUMULATION INDICATE THAT SOLDER HEAT IS A MAJOR CAUSE OF EARLY AND FUTURE FAILURE. PLEASE PAY ATTENTION TO YOUR SOLDERING PROCESS.



DRAWN BY:	CHECKED BY:	APPROVED BY:	DATE:
BC			5.2.90
			PAGE: 1 OF 1
			SCALE: N/A