



We Tame Photons to Work for You!



Products > LEDs > Thru-Hole > Round > 5mm > Standard > Standard Intensity



### Features / Options

- ▶ State-of-the-Art, High Brightness Chip Technology
- ▶ Choice of Colors and Lens Finishes
- ▶ Lead Frame / Lens Casting Reliability
- ▶ Easy-to-Solder Leads, Tin Finish
- ▶ Available Bulk or on Tape and Reel
- ▶ Lead Trimming and Forming Available
- ▶ Custom Shapes, Easily Tooled, Low Minimum

### Applications / Uses

- ▶ Board or Panel Indication or Illumination
- ▶ Annunciator and Control Panels
- ▶ Telecom Switches and Central Station Equipment
- ▶ Large Panel Indicators

Part Number:	Brightness	Dice Material	Emitted Color	Peak Wavelength	Epoxy Lens	Operating Typ Vf (V)	Intensity Typ, mcd @ 20 mA	View Angle 2x Theta		
SSL-LX5093AD	STANDARD	GaAsP	Amber	605	Diffused	2.1	30	60		—
SSL-LX5093AT	STANDARD	GaAsP	Amber	605	Color Tinted	2.1	80	30		—
SSL-LX5093GD	STANDARD	GaP	Green	565	Diffused	2.0	30	60		—
SSL-LX5093HD	STANDARD	GaP	Red	700	Diffused	2.1	30	60		—
SSL-LX5093ID	STANDARD	GaAsP	Red	635	Diffused	2.0	40	60		—
SSL-LX5093IGW	STANDARD	GaAsP	Red/Green	635	White Diffused	2.1	30	60		—
SSL-LX5093IT	STANDARD	GaAsP	Red	635	Color Tinted	2	80	30		—
SSL-LX5093SBC/A	STANDARD	SiC	Blue	430	Clear	3.5	100	30		—
SSL-LX5093SBD	STANDARD	SiC	Blue	430	Diffused	4.5	25	20		—
SSL-LX5093SGC/B	STANDARD	GaP	Green	565	Clear	2.1	300	30		—

UNCONTROLLED DOCUMENT

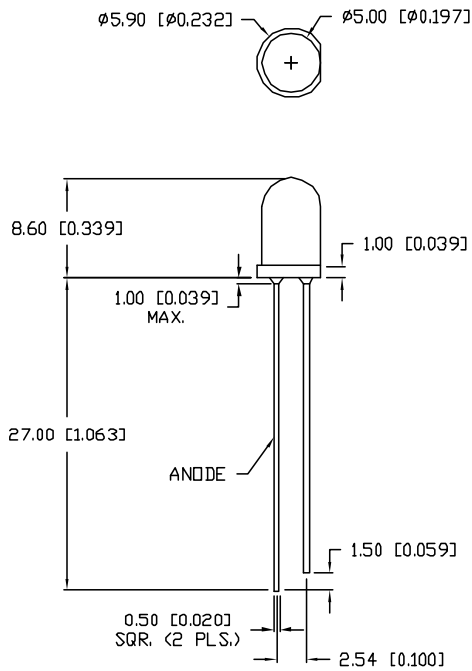

PART NUMBER  
SSL-LX50931D

REV.  
D

REV.	E.C.N. NUMBER AND REVISION COMMENTS	DATE
A	CHG'D AXIAL INTENSITY.	5.15.90
B	REDRAWN, UPDATED SPECS.	1.6.95
C	E.C.N. #10BRDR. & REDRAWN IN 3D.	5.24.01
D	E.C.N. #1114B	10.19.06

ELECTRO-OPTICAL CHARACTERISTICS  $T_A=25^\circ\text{C}$   $I_f=20\text{mA}$

PARAMETER	MIN	TYP	MAX	UNITS	TEST COND
PEAK WAVELENGTH		635		nm	
FORWARD VOLTAGE		2.0	2.5	$V_f$	
REVERSE VOLTAGE	5.0			$V_r$	$I_f=100\mu\text{A}$
AXIAL INTENSITY		40		mcd	$I_f=20\text{mA}$
VIEWING ANGLE		60		2x theta	
EMITTED COLOR:	RED				
EPOXY LENS FINISH:	RED DIFFUSED				

LIMITS OF SAFE OPERATION AT  $25^\circ\text{C}$

PARAMETER	MAX	UNITS
PEAK FORWARD CURRENT*	150	mA
STEADY CURRENT	30	mA
POWER DISSIPATION	105	mW
DERATE FROM $25^\circ\text{C}$	-1.2	$\text{mW}/^\circ\text{C}$
OPERATING, STORAGE TEMP.	-40 TO +85	$^\circ\text{C}$
SOLDERING TEMP.	+260	$^\circ\text{C}$
2.0mm FROM BODY		3 SEC. MAX

\*  $t < 10\mu\text{s}$



UNCONTROLLED DOCUMENT

\*UNLESS OTHERWISE SPECIFIED TOLERANCES PER DECIMAL PRECISION ARE: X=±1 (±0.039), XI=±0.5 (±0.020), XIX=±0.25 (±0.010), XXX=±0.127 (±0.005). LEAD SIZE=±0.05 (±0.002), LEAD LENGTH=±0.75 (±0.030). MIN= -0.00 DECIMAL PRECISION MAX.= +0.00 DECIMAL PRECISION

REV. D	PART NUMBER SSL-LX50931D
-----------	-----------------------------

**CONFIDENTIAL INFORMATION**  
THE INFORMATION CONTAINED IN THIS DOCUMENT IS THE PROPERTY OF LUMEX INC. EXCEPT AS SPECIFICALLY AUTHORIZED IN WRITING BY LUMEX INC., THE HOLDER OF THIS DOCUMENT SHALL KEEP ALL INFORMATION CONTAINED HEREIN CONFIDENTIAL AND SHALL PROTECT SAME IN WHOLE OR IN PART FROM DISCLOSURE AND DISSEMINATION TO ALL THIRD PARTIES.



T-5mm (T-1 3/4) 635nm RED LED,  
RED DIFFUSED LENS.

**RELIABILITY NOTE**  
OUR MANY YEARS OF EXPERIENCE DATA ACCUMULATION INDICATE THAT SOLDER HEAT IS A MAJOR CAUSE OF EARLY AND FUTURE FAILURE. PLEASE PAY ATTENTION TO YOUR SOLDERING PROCESS.

DRAWN BY: JC	CHECKED BY:	APPROVED BY:	DATE: 10.19.06 PAGE: 1 OF 1 SCALE: N/A
-----------------	-------------	--------------	--