



We Tame Photons to Work for You!



Products > LEDs > Surface Mount > 2mm X 3mm Molded Package

Features / Options

Applications / Uses



- ▶ State-of-the-Art, High Brightness Chip Technology
- ▶ Choice of Colors and Lens Finishes
- ▶ Lead Frame / Lens Casting Reliability
- ▶ Easy-to-Solder Leads, Tin Finish
- ▶ Available Bulk or on Tape and Reel
- ▶ Lead Trimming and Forming Available
- ▶ Custom Shapes, Easily Tooled, Low Minimum

- ▶ Board or Panel Indication or Illumination
- ▶ Annunciator and Control Panels
- ▶ Telecom Switches and Central Station Equipment
- ▶ Large Panel Indicators

Part Number:	Brightness	Dice Material	Emitted Color	Peak Wavelength	Epoxy Lens	Operating Typ Vf (V)	Intensity Typ, mcd @ 20 mA	View Angle 2x Theta		
SML-LX23AC-TR	HIGH	AlInGaP	Amber	610	Clear	2.1	30	90		—
SML-LX23GC-TR	STANDARD	GaP	Green	565	Clear	2.1	20	90		—
SML-LX23IC-TR	STANDARD	GaAsP	Red	635	Clear	2	20	90		—
SML-LX23SIC-TR	HIGH	AlInGaP	Red	636	Clear	2.0	300	90		—
SML-LX23SOC-TR	HIGH	AlInGaP	Orange	610	Clear	1.95	300	90		—
SML-LX23SRC-TR	STANDARD	GaAlAs	Red	660	Clear	1.8	150	90		—
SML-LX23SUGC-TR	HIGH	AlInGaP	Green	574	Clear	2.25	80	90		—
SML-LX23SYC-TR	HIGH	AlInGaP	Yellow	590	Clear	2.0	200	90		—
SML-LX23UPGC-TR	HIGH	InGaN	Green	525	Clear	3.5	150	90		—
SML-LX23USBC-TR	HIGH	InGaN	Blue	470	Clear	3.5	60	90		—

UNCONTROLLED DOCUMENT

PART NUMBER
SML-LX23SIC-TR

REV.
A

REV.	E.C.N. NUMBER AND REVISION COMMENTS	DATE
A	E.C.N. #11148.	2.8.05

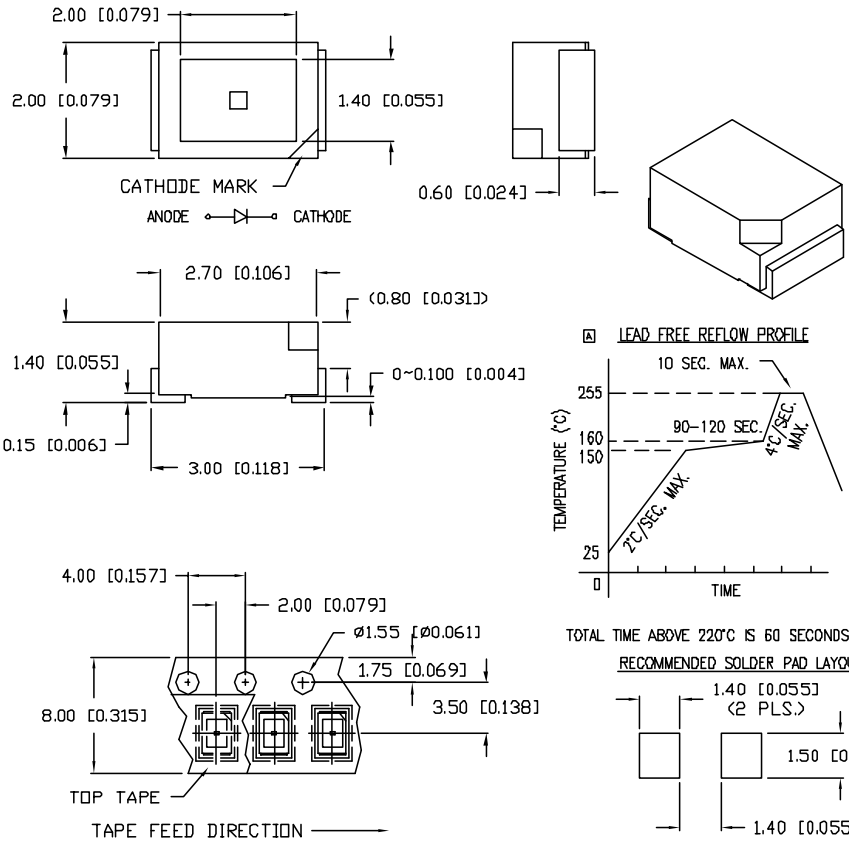

ELECTRO-OPTICAL CHARACTERISTICS $T_A=25^\circ\text{C}$ $I_f=20\text{mA}$

PARAMETER	MIN	TYP	MAX	UNITS	TEST COND
PEAK WAVELENGTH		638		nm	
FORWARD VOLTAGE		2.0	2.6	V_f	
REVERSE VOLTAGE	5.0			V_r	$I_f=100\mu\text{A}$
AXIAL INTENSITY		300		md	$I_f=20\text{mA}$
VIEWING ANGLE		90		2x theta	
EMITTED COLOR:	RED				
EPOXY LENS FINISH:	WATER CLEAR				

LIMITS OF SAFE OPERATION AT 25°C PER CHIP

PARAMETER	MAX	UNITS
PEAK FORWARD CURRENT*	160	mA
STEADY CURRENT	30	mA
POWER DISSIPATION	100	mW
DERATE FROM 25°C	-1.2	mW/°C
OPERATING TEMP.	-25 TO +80	°C
STORAGE TEMP.	-30 TO +85	°C

* $t < 10\mu\text{s}$

NOTES:
1. THE CATHODE IS ORIENTED TOWARDS THE TAPE SPROCKET HOLE.

CAUTION: MOISTURE SENSITIVE DEVICE
PER JEDEC LEVEL 4 STANDARDS

UNCONTROLLED DOCUMENT

*UNLESS OTHERWISE SPECIFIED TOLERANCES PER DECIMAL PRECISION ARE: X=±1 (±0.039), XX=±0.5 (±0.020), XXX=±0.25 (±0.010), XXXX=±0.127 (±0.005). LEAD SIZE=±0.05 (0.002), LEAD LENGTH=±0.75 (±0.030). MIN= ^{+0.00} DECIMAL PRECISION MAX= ^{+0.00} DECIMAL PRECISION

REV.	PART NUMBER
A	SML-LX23SIC-TR

CONFIDENTIAL INFORMATION
THE INFORMATION CONTAINED IN THIS DOCUMENT IS THE PROPERTY OF LUMEX INC. EXCEPT AS SPECIFICALLY AUTHORIZED IN WRITING BY LUMEX INC., THE HOLDER OF THIS DOCUMENT SHALL KEEP ALL INFORMATION CONTAINED HEREIN CONFIDENTIAL AND SHALL PROTECT SAME IN WHOLE OR IN PART FROM DISCLOSURE AND DISSEMINATION TO ALL THIRD PARTIES.

RELIABILITY NOTE
OUR MANY YEARS OF EXPERIENCE DATA ACCUMULATION INDICATE THAT SOLDER HEAT IS A MAJOR CAUSE OF EARLY AND FUTURE FAILURE. PLEASE PAY ATTENTION TO YOUR SOLDERING PROCESS.



2mm x 3mm SURFACE MOUNT WITH REFLECTOR, 638nm SUPER INTENSITY RED LED, WATER CLEAR LENS.		DRAWN BY: BC	CHECKED BY:	APPROVED BY:	DATE: 12.21.00 PAGE: 1 OF 1 SCALE: N/A
---	--	-----------------	-------------	--------------	--