



We Tame Photons to Work for You!



Products > LEDs > Surface Mount > 2832 Package



Features / Options

- ▶ State-of-the-Art, High Brightness Chip Technology
- ▶ Choice of Colors and Lens Finishes
- ▶ Lead Frame / Lens Casting Reliability
- ▶ Easy-to-Solder Leads, Tin Finish
- ▶ Available Bulk or on Tape and Reel
- ▶ Lead Trimming and Forming Available
- ▶ Custom Shapes, Easily Tooled, Low Minimum

Applications / Uses

- ▶ Board or Panel Indication or Illumination
- ▶ Annunciator and Control Panels
- ▶ Telecom Switches and Central Station Equipment
- ▶ Large Panel Indicators

Part Number:	Brightness	Dice Material	Emitted Color	Peak Wavelength	Epoxy Lens	Operating Typ Vf (V)	Intensity Typ, mcd @ 20 mA	View Angle 2x Theta		
SML-LX2832DRC-TR	STANDARD	GaAlAs	Red	660	Clear	2.0	40	120		—
SML-LX2832GC-TR	STANDARD	GaP	Green	565	Clear	2.1	25	120		—
SML-LX2832GYC-TR	STANDARD	GaP	Green/Yellow	565	Clear	2.2/2.1	15	120		—
SML-LX2832IC-TR	STANDARD	GaAsP	Red	635	Clear	2	25	120		—
SML-LX2832IGC-TR	STANDARD	GaAsP / GaP	Red/Green	635	Clear	2.0/2.1	25	120		—
SML-LX2832IYC-TR	STANDARD	GaAsP / GaAsP	Red/Yellow	635	Clear	2.0/2.1	25	120		—
SML-LX2832LGC-TR	STANDARD	GaP	Green	565	Clear	2.1	25	120		—
SML-LX2832LIC-TR	STANDARD	GaAsP	Red	635	Clear	2.0	25	120		—
SML-LX2832LYC-TR	STANDARD	GaAsP	Yellow	585	Clear	2.1	15	120		—
SML-LX2832PGC-TR	STANDARD	GaP	Green	555	Clear	2.1	15	120		—

SML-LX2832SGC-TR		STANDARD	GaP	Green	565	Clear	2.1	28	120		—
SML-LX2832SIC-TR		HIGH	AlInGaP	Red	636	Clear	2.0	250	120		—
SML-LX2832SISUGCTR		HIGH	AlInGaP	Red/Green	636	Clear	2.0	60	120		—
SML-LX2832SISUGSBC		HIGH	AlInGaP	Red/Green	636	Clear	2.0/2.2/3.5	80	120		—
SML-LX2832SOC-TR		HIGH	AlInGaP	Orange	610	Clear	2.0	300	120		—
SML-LX2832SRC-TR		STANDARD	GaAlAsP	Red	660	Clear	1.8	100	120		—
SML-LX2832SRC/B-TR		STANDARD	GaAlAs	Red	660	Clear	1.7	65	120		—
SML-LX2832SRC/C-TR		STANDARD	GaAlAs	Red	660	Clear	1.7	100	120		—
SML-LX2832SRGSBTR		STANDARD	GaAlAs / GaP / InGaN/SiC	RGB	660	Clear	1.8/2.2/3.5	110	120		—
SML-LX2832SRUGUSB		STANDARD	GaAlAs	Red/Green	660	Clear	1.7/2.2/3.5	110	120		—
SML-LX2832SUGC-TR		HIGH	AlInGaP	Green	574	Clear	2.2	150	120		—
SML-LX2832SUGSICTR		HIGH	AlInGaP	Green/Red	574	Clear	2.0	25	120		—
SML-LX2832SYC-TR		HIGH	AlInGaP	Yellow	590	Clear	2.0	140	120		—
SML-LX2832SYSUGCTR		HIGH	AlInGaP	Yellow/Green	590	Clear	2.0	60	120		—
SML-LX2832UPGC-TR		HIGH	InGaN	Green	525	Clear	3.5	170	120		—
SML-LX2832USBC-TR		HIGH	InGaN	Blue	470	Clear	3.5	60	120		—
SML-LX2832UWC-TR		HIGH	InGaN	White	-	Clear	3.5	150	120		—
SML-LX2832YC-TR		STANDARD	GaAsP	Yellow	585	Clear	2.1	15	120		—
SML-LX2832YGC-TR		STANDARD	GaAsP / GaP	Yellow/Green	585	Clear	2.1	15	120		—
SML-LX2832ZIC-TR		HIGH	AlInGaP	Red	630	Clear	2.4	800	120		—

UNCONTROLLED DOCUMENT

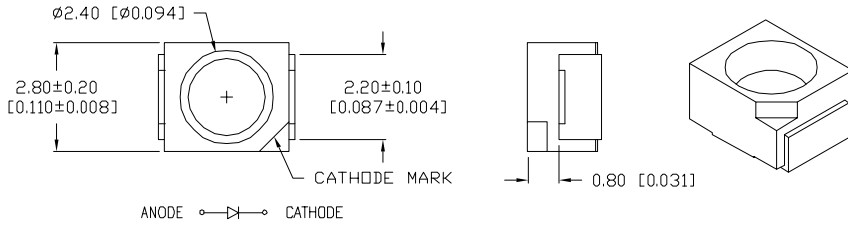

ANODE CATHODE

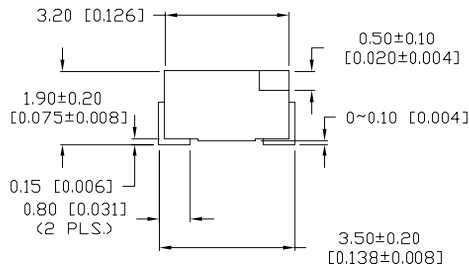

LEAD FREE REFLOW PROFILE

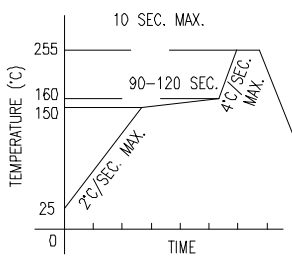

TOTAL TIME ABOVE 220°C IS 60 SECONDS MAX.

RECOMMENDED SOLDER PAD LAYOUT

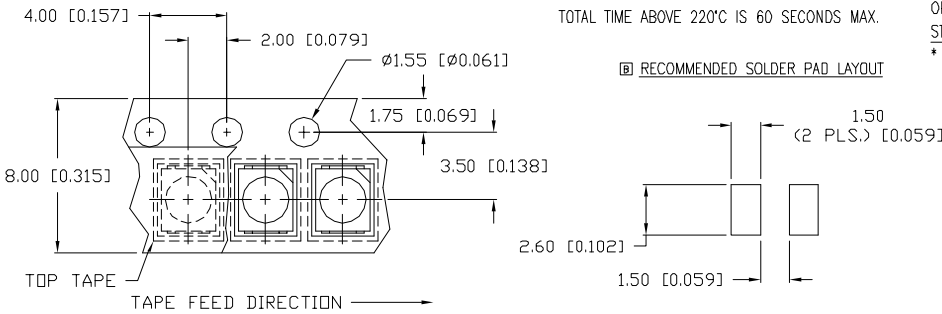

*UNLESS OTHERWISE SPECIFIED TOLERANCES PER DECIMAL PRECISION ARE: X=±1 (±0.039), X.X=±0.5 (±0.020), X.XX=±0.25 (±0.010), X.XXX=±0.127 (±0.005). LEAD SIZE=±0.05 (±0.002), LEAD LENGTH=±0.75 (±0.030). MIN=+DECIMAL PRECISION -0.00 MAX.=+0.00 -DECIMAL PRECISION

PART NUMBER		REV.
SML-LX2832SIC-TR		B
REV.	E.C.N. NUMBER AND REVISION COMMENTS	DATE
A	E.C.N. #10967.	3.14.03
B	E.C.N. #11450.	10.17.07

ELECTRO-OPTICAL CHARACTERISTICS T _A =25°C I _f =20mA					
PARAMETER	MIN	TYP	MAX	UNITS	TEST COND
PEAK WAVELENGTH		636		nm	
FORWARD VOLTAGE		2.0	2.6	V _f	
REVERSE VOLTAGE	5.0			V _r	I _r =100µA
AXIAL INTENSITY		250		mcd	I _f =20mA
VIEWING ANGLE		120		2x theta	
EMITTED COLOR:	RED				
EPOXY LENS FINISH:	WATER CLEAR				

LIMITS OF SAFE OPERATION AT 25°C		
PARAMETER	MAX	UNITS
PEAK FORWARD CURRENT*	160	mA
STEADY CURRENT	30	mA
POWER DISSIPATION	100	mW
DERATE FROM 25°C	-1.2	mW/°C
OPERATING TEMP.	-30 TO +85	°C
STORAGE TEMP.	-40 TO +85	°C

* t<10µs

NOTES:

- THE POLARITY MARK IS ORIENTED TOWARDS THE TAPE SPROCKET HOLE.

CAUTION: MOISTURE SENSITIVE DEVICE
PER JEDEC LEVEL 4 STANDARDS



UNCONTROLLED DOCUMENT

REV.	PART NUMBER
B	SML-LX2832SIC-TR
2.8mm x 3.2mm SURFACE MOUNT LED WIT REFLECTOR, 636nm SUPER HIGH INTENSITY RED LED, WATER CLEAR LENS, 2,000 PIECES PER TAPE AND REEL.	

CONFIDENTIAL INFORMATION
THE INFORMATION CONTAINED IN THIS DOCUMENT IS THE PROPERTY OF LUMEX INC. EXCEPT AS SPECIFICALLY AUTHORIZED IN WRITING BY LUMEX INC., THE HOLDER OF THIS DOCUMENT SHALL KEEP ALL INFORMATION CONTAINED HEREIN CONFIDENTIAL AND SHALL PROTECT SAME IN WHOLE OR IN PART FROM DISCLOSURE AND DISSEMINATION TO ALL THIRD PARTIES.

RELIABILITY NOTE
OUR MANY YEARS OF EXPERIENCE DATA ACCUMULATION INDICATE THAT SOLDER HEAT IS A MAJOR CAUSE OF EARLY AND FUTURE FAILURE. PLEASE PAY ATTENTION TO YOUR SOLDERING PROCESS.



DRAWN BY:	CHECKED BY:	APPROVED BY:	DATE:
BC			1.11.01
			PAGE: 1 OF 1
			SCALE: N/A