

HFBR-0500Z Series

Versatile Link

The Versatile Fiber Optic Connection



Data Sheet

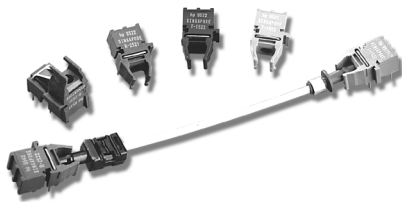

Description

The Versatile Link series is a complete family of fiber optic link components for applications requiring a low cost solution. The HFBR-0500Z series includes transmitters, receivers, connectors and cable specified for easy design. This series of components is ideal for solving problems with voltage isolation/insulation, EMI/RFI immunity or data security. The optical link design is simplified by the logic compatible receivers and complete specifications for each component. The key optical and electrical parameters of links configured with the HFBR-0500Z family are fully guaranteed from 0° to 70°C.

A wide variety of package configurations and connectors provide the designer with numerous mechanical solutions to meet application requirements. The transmitter and receiver compo-

nents have been designed for use in high volume/low cost assembly processes such as auto insertion and wave soldering.

Transmitters incorporate a 660 nm LED. Receivers include a monolithic dc coupled, digital IC receiver with open collector Schottky output transistor. An internal pullup resistor is available for use in the HFBR-25X1Z/2Z/4Z receivers. A shield has been integrated into the receiver IC to provide additional, localized noise immunity.

Internal optics have been optimized for use with 1 mm diameter plastic optical fiber. Versatile Link specifications incorporate all connector interface losses. Therefore, optical calculations for common link applications are simplified.

Features

- RoHS-compliant
- Low cost fiber optic components
- Enhanced digital links: dc-5 MBd
- Extended distance links up to 120 m at 40 kBd
- Low current link: 6 mA peak supply current
- Horizontal and vertical mounting
- Interlocking feature
- High noise immunity
- Easy connecting: simplex, duplex, and latching connectors
- Flame retardant
- Transmitters incorporate a 660 nm red LED for easy visibility
- Compatible with standard TTL circuitry

Applications

- Reduction of lightning/voltage transient susceptibility
- Motor controller triggering
- Data communications and local area networks
- Electromagnetic Compatibility (EMC) for regulated systems: FCC, VDE, CSA, etc.
- Tempest-secure data processing equipment
- Isolation in test and measurement instruments
- Error free signalling for industrial and manufacturing equipment
- Automotive communications and control networks
- Noise immune communication in audio and video equipment

HFBR-0500Z Series Part Number Guide

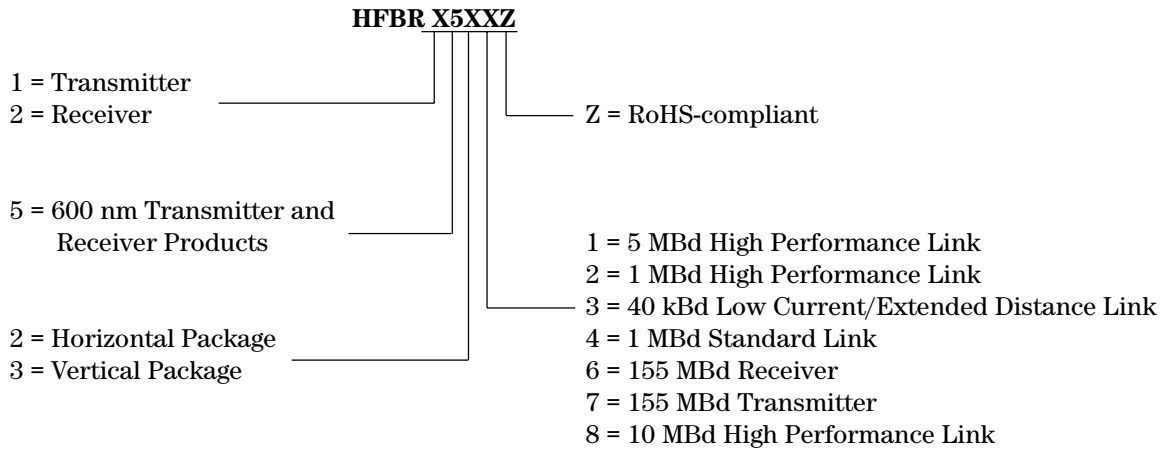

Link Selection Guide

(Links specified from 0 to 70°C, for plastic optical fiber unless specified.)

Signal Rate	Distance (m) 25°C	Distance (m)	Transmitter	Receiver
40 kBd	120	110	HFBR-1523Z	HFBR-2523Z
1 MBd	20	10	HFBR-1524Z	HFBR-2524Z
1 MBd	55	45	HFBR-1522Z	HFBR-2522Z
5 Mbd	30	20	HFBR-1521Z	HFBR-2521Z

Evaluation Kit

HFBR-0500Z 1 MBd Versatile Link:

This kit contains: HFBR-1524Z Tx, HFBR-2524Z Rx, polishing kit, 3 styles of plastic connectors, Bulkhead feedthrough, 5 meters of 1 mm diameter plastic cable, lapping film and grit paper, and HFBR-0500Z data sheet.

Application Literature

Application Note 1035 (Versatile Link)

Package and Handling Information

The compact Versatile Link package is made of a flame retardant VALOX® UL 94 V-0 material (UL file # E121562) and uses the same pad layout as a standard, eight pin dual-in-line package. Vertical and horizontal mountable parts are available. These low profile Versatile Link packages are stackable and are enclosed to provide a dust resistant seal. Snap

action simplex, simplex latching, duplex, and duplex latching connectors are offered with simplex or duplex cables.

Package Orientation

Performance and pinouts for the vertical and horizontal packages are identical. To provide additional attachment support for the vertical Versatile Link housing,

the designer has the option of using a self-tapping screw through a printed circuit board into a mounting hole at the bottom of the package. For most applications this is not necessary.

Package Housing Color

Versatile Link components and simplex connectors are color coded to eliminate confusion

VALOX® is a registered trademark of the General Electric Corporation.

when making connections. Receivers are blue and transmitters are gray, except for the HFBR-15X3Z transmitter, which is black.

Handling

Versatile Link components are auto-insertable. When wave soldering is performed with Versatile Link components, the optical port plug should be left in to prevent contamination of the port. Do not use reflow solder processes (i.e., infrared reflow or vapor-phase reflow). Nonhalogenated water soluble fluxes (i.e., 0% chloride), not rosin based fluxes, are recommended for use with Versatile Link components.

Versatile Link components are moisture sensitive devices and are shipped in a moisture sealed bag. If the components are exposed to air for an extended period of time, they may require a baking step before the soldering process. Refer to the special labeling on the shipping tube for details.

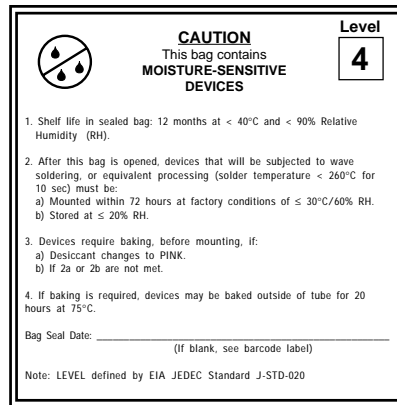

Recommended Chemicals for Cleaning/Degreasing

Alcohols: methyl, isopropyl, isobutyl. *Aliphatics:* hexane, heptane. *Other:* soap solution, naphtha.

Do not use partially halogenated hydrocarbons such as 1,1,1 trichloroethane, ketones such as MEK, acetone, chloroform, ethyl acetate, methylene dichloride, phenol, methylene chloride, or N-methylpyrrolidone. Also, Avago does not recommend the use of cleaners that use halogenated hydrocarbons because of their potential environmental harm.

Mechanical Dimensions Horizontal Modules

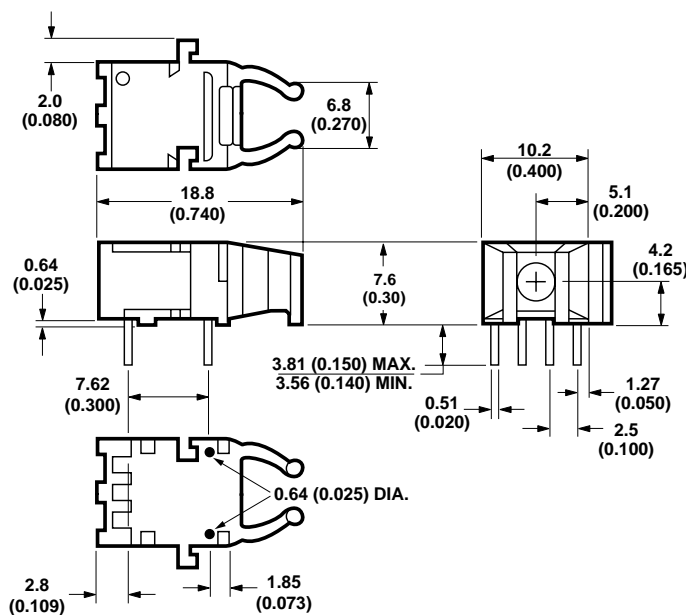

Vertical Modules

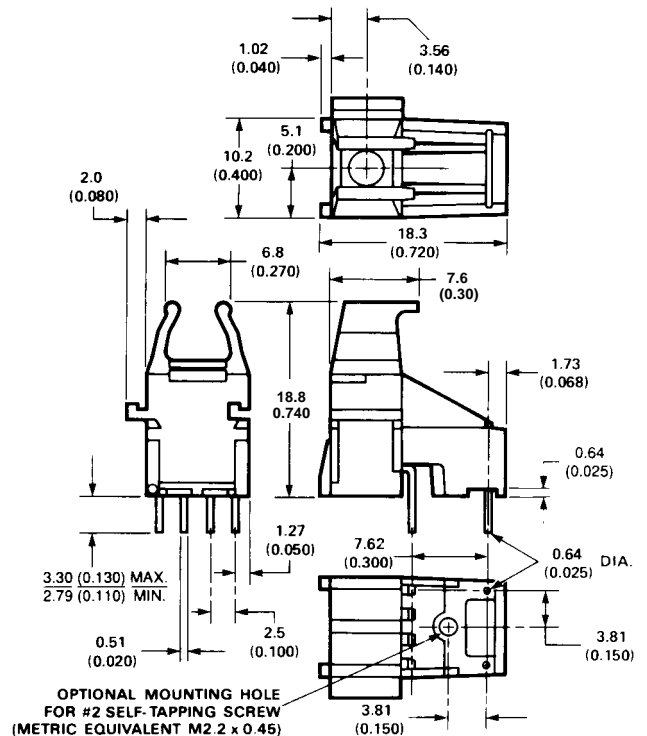

Versatile Link Printed Board Layout Dimensions
Horizontal Module

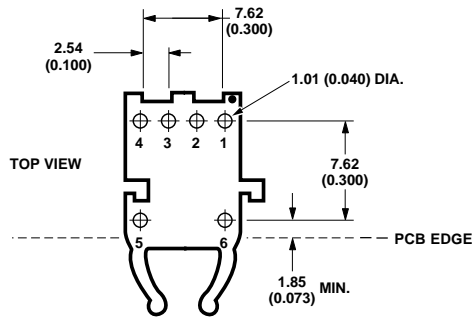

DIMENSIONS IN MILLIMETERS (INCHES).

Vertical Module

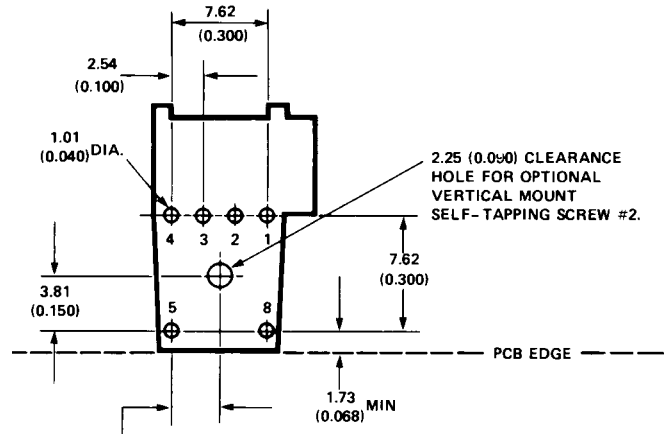

DIMENSIONS IN MILLIMETERS AND (INCHES)

Interlocked (Stacked) Assemblies
(refer to Figure 1)

Horizontal packages may be stacked by placing units with pins facing upward. Initially engage the interlocking mechanism by sliding the L bracket body from above into the L slot body of the lower package. Use a straight edge, such as a ruler, to bring all

stacked units into uniform alignment. This technique prevents potential harm that could occur to fingers and hands of assemblers from the package pins. Stacked horizontal packages can be disengaged if necessary. Repeated stacking and unstacking causes no damage to individual units.

Stacking Horizontal Modules

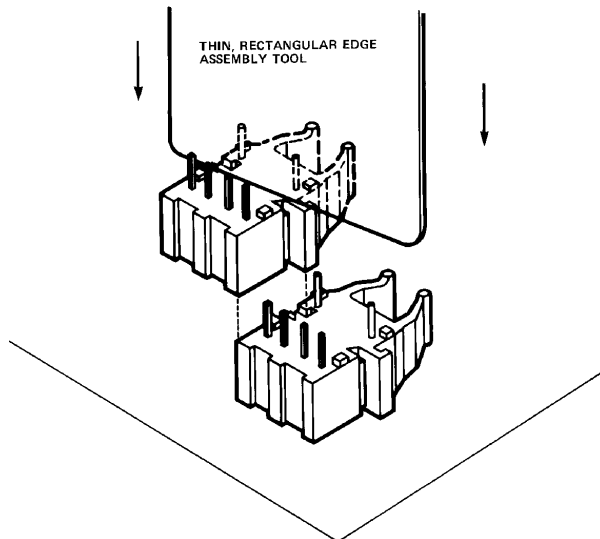

Stacking Vertical Modules

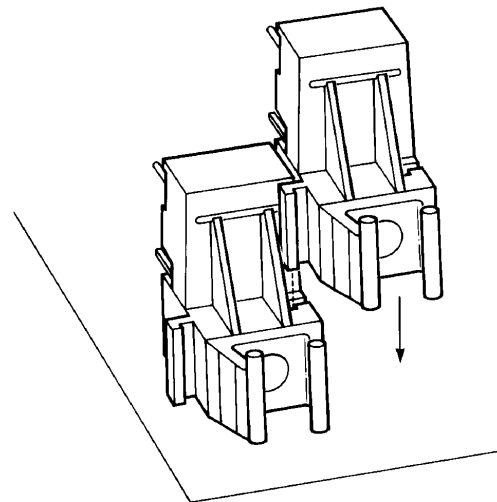

Figure 1. Interlocked (stacked) horizontal or vertical packages.

5 MBd Link (HFBR-15X1Z/25X1Z)

System Performance 0 to 70°C unless otherwise specified.

	Parameter	Symbol	Min.	Typ.	Max.	Units	Conditions	Ref.
High Performance 5 MBd	Data Rate		dc		5	MBd	BER $\leq 10^{-9}$, PRBS:27-1	
	Link Distance (Standard Cable)	ℓ	19 27	48		m m	$I_{Fdc} = 60 \text{ mA}$ $I_{Fdc} = 60 \text{ mA}, 25^\circ\text{C}$	Fig. 3 Note 3
	Link Distance (Improved Cable)	ℓ	22 27	53		m m	$I_{Fdc} = 60 \text{ mA}$ $I_{Fdc} = 60 \text{ mA}, 25^\circ\text{C}$	Fig. 4 Note 3
	Propagation Delay	t_{PLH} t_{PHL}		80 50	140 140	ns ns	$R_L = 560 \Omega, C_L = 30 \text{ pF}$ fiber length = 0.5 m $-21.6 \leq P_R \leq -9.5 \text{ dBm}$	Fig. 5, 8 Notes 1, 2
	Pulse Width Distortion $t_{PLH}-t_{PHL}$	t_D		30		ns	$P_R = -15 \text{ dBm}$ $R_L = 560 \Omega, C_L = 30 \text{ pF}$	Fig. 5, 7

Notes:

1. The propagation delay for one metre of cable is typically 5 ns.
2. Typical propagation delay is measured at $P_R = -15 \text{ dBm}$.
3. Estimated typical link life expectancy at 40°C exceeds 10 years at 60 mA.

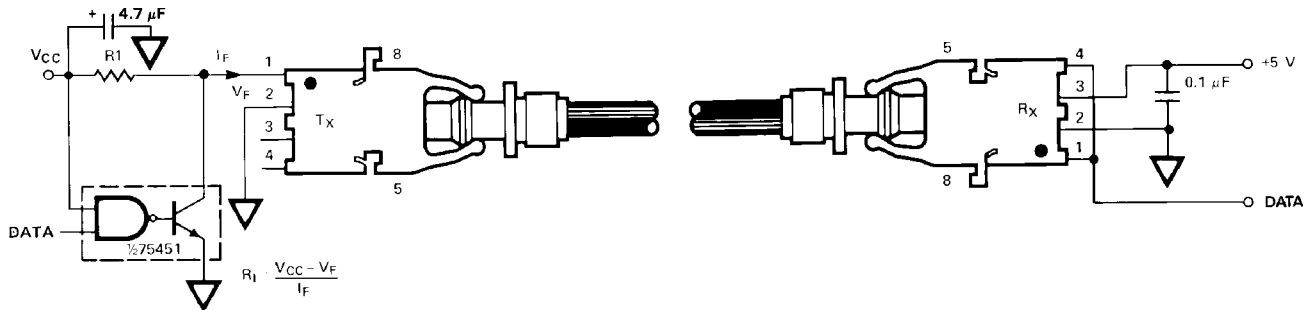

Figure 2. Typical 5 MBd interface circuit.

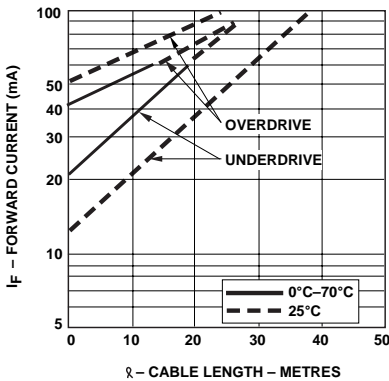

Figure 3. Guaranteed system performance with standard cable (HFBR-15X1Z/25X1Z).

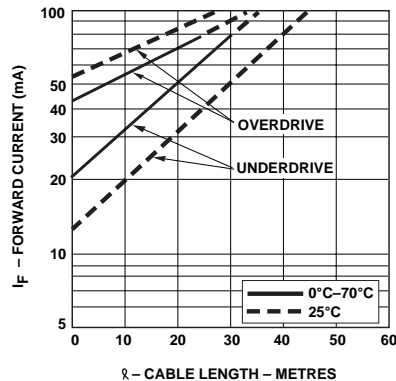

Figure 4. Guaranteed system performance with improved cable (HFBR-15X1Z/25X1Z).

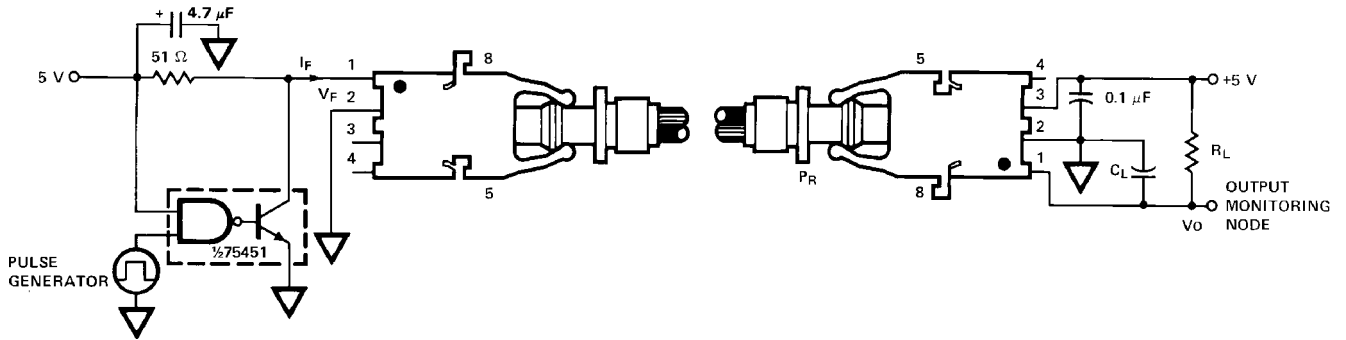

Figure 5. 5 MBd propagation delay test circuit.

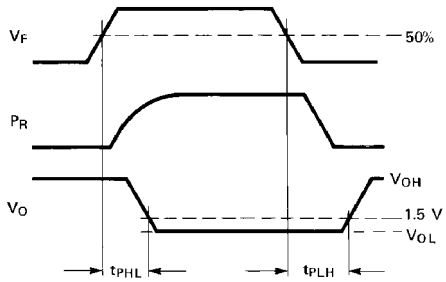

Figure 6. Propagation delay test waveforms.

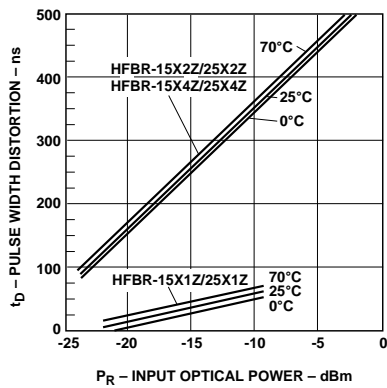

Figure 7. Typical link pulse width distortion vs. optical power.

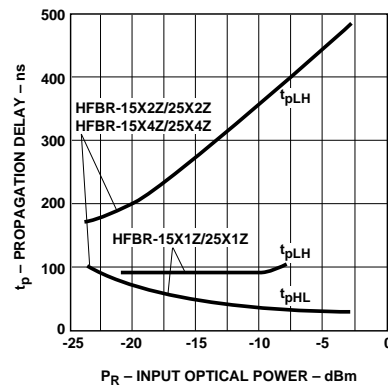
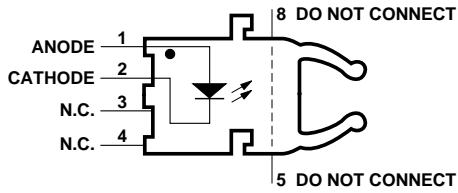

Figure 8. Typical link propagation delay vs. optical power.

HFBR-15X1Z Transmitter



Pin #	Function
1	Anode
2	Cathode
3	Open
4	Open
5	Do not connect
8	Do not connect

Note: Pins 5 and 8 are for mounting and retaining purposes only. Do not electrically connect these pins.

Absolute Maximum Ratings

Parameter	Symbol	Min.	Max.	Units	Reference
Storage Temperature	T_S	-40	+85	°C	
Operating Temperature	T_A	-40	+85	°C	
Lead Soldering Cycle	Temp.		260	°C	Note 1
	Time		10	sec	
Forward Input Current	I_{FPK}		1000	mA	Note 2, 3
	I_{Fdc}		80		
Reverse Input Voltage	V_{BR}		5	V	

Notes:

- 1.6 mm below seating plane.
- Recommended operating range between 10 and 750 mA.
- 1 μ s pulse, 20 μ s period.

All HFBR-15XXZ LED transmitters are classified as IEC 825-1 Accessible Emission Limit (AEL) Class 1 based upon the current proposed draft scheduled to go into effect on January 1, 1997. AEL Class 1 LED devices are considered eye safe. Contact your local Avago sales representative for more information.

Transmitter Electrical/Optical Characteristics 0°C to 70°C unless otherwise specified.

Parameter	Symbol	Min.	Typ. ^[5]	Max.	Units	Conditions	Ref.
Transmitter Output Optical Power	P_T	-16.5		-7.6	dBm	$I_{Fdc} = 60 \text{ mA}$	Notes 1, 2
		-14.3		-8.0	dBm	$I_{Fdc} = 60 \text{ mA}, 25^\circ\text{C}$	
Output Optical Power Temperature Coefficient	$\Delta P_T / \Delta T$		-0.85		%/°C		
Peak Emission Wavelength	λ_{PK}		660		nm		
Forward Voltage	V_F	1.45	1.67	2.02	V	$I_{Fdc} = 60 \text{ mA}$	
Forward Voltage Temperature Coefficient	$\Delta V_F / \Delta T$		-1.37		mV/°C		Fig. 9
Effective Diameter	D		1		mm		
Numerical Aperture	NA		0.5				
Reverse Input Breakdown Voltage	V_{BR}	5.0	11.0		V	$I_{Fdc} = 10 \mu\text{A}, T_A = 25^\circ\text{C}$	
Diode Capacitance	C_O		86		pF	$V_F = 0, f = \text{MHz}$	
Rise Time	t_r		80		ns	10% to 90%,	Note 3
Fall Time	t_f		40		ns	$I_F = 60 \text{ mA}$	

Notes:

1. Measured at the end of 0.5 m standard fiber optic cable with large area detector.
2. Optical power, P (dBm) = 10 Log [P(μW)/1000 μW].
3. Rise and fall times are measured with a voltage pulse driving the transmitter and a series connected 50 Ω load. A wide bandwidth optical to electrical waveform analyzer, terminated to a 50 Ω input of a wide bandwidth oscilloscope, is used for this response time measurement.

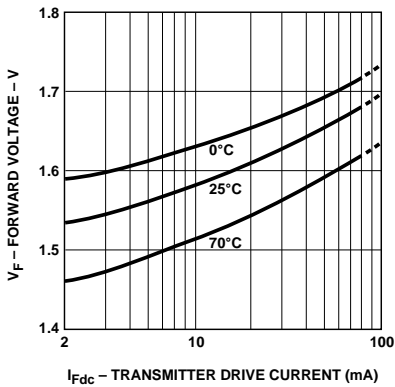

Figure 9. Typical forward voltage vs. drive current.

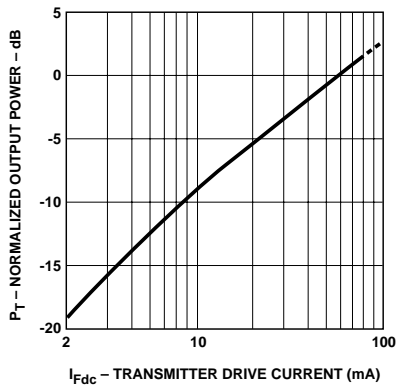
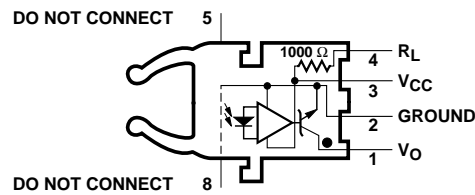

Figure 10. Normalized typical output power vs. drive current.

HFBR-25X1Z Receiver



Pin #	Function
1	V_O
2	Ground
3	V_{CC}
4	R_L
5	Do not connect
8	Do not connect

Note: Pins 5 and 8 are for mounting and retaining purposes only. Do not electrically connect these pins.

Absolute Maximum Ratings

Parameter	Symbol	Min.	Max.	Units	Reference
Storage Temperature	T_S	-40	+85	°C	
Operating Temperature	T_A	-40	+85	°C	
Lead Soldering Cycle	Temp.		260	°C	Note 1
	Time		10	sec	
Supply Voltage	V_{CC}	-0.5	7	V	Note 2
Output Collector Current	I_{OAV}		25	mA	
Output Collector Power Dissipation	P_{OD}		40	mW	
Output Voltage	V_O	-0.5	18	V	
Pull-up Voltage	V_P	-5	V_{CC}	V	
Fan Out (TTL)	N		5		

Notes:

- 1.6 mm below seating plane.
- It is essential that a bypass capacitor 0.01 μF be connected from pin 2 to pin 3 of the receiver. Total lead length between both ends of the capacitor and the pins should not exceed 20 mm.

Receiver Electrical/Optical Characteristics

0°C to 70°C, 4.75 V $\leq V_{CC} \leq 5.25$ V unless otherwise specified

Parameter	Symbol	Min.	Typ.	Max.	Units	Conditions	Ref.
Input Optical Power Level for Logic "0"	$P_{R(L)}$	-21.6		-9.5	dBm	$V_{OL} = 0.5$ V $I_{OL} = 8$ mA	Notes 1, 2, 4
		-21.6		-8.7		$V_{OL} = 0.5$ V $I_{OL} = 8$ mA, 25°C	
Input Optical Power Level for Logic "1"	$P_{R(H)}$			-43	dBm	$V_{OL} = 5.25$ V $I_{OH} \leq 250$ μA	Note 1
High Level Output Current	I_{OH}		5	250	μA	$V_O = 18$ V, $P_R = 0$	Note 3
Low Level Output Current	V_{OL}		0.4	0.5	V	$I_{OL} = 8$ mA, $P_R = P_{R(L)MIN}$	Note 3
High Level Supply Current	I_{CCH}		3.5	6.3	mA	$V_{CC} = 5.25$ V, $P_R = 0$	Note 3
Low Level Supply Current	I_{CCL}		6.2	10	mA	$V_{CC} = 5.25$ V $P_R = -12.5$ dBm	Note 3
Effective Diameter	D		1		mm		
Numerical Aperture	NA		0.5				
Internal Pull-up Resistor	R_L	680	1000	1700	Ω		

Notes:

- Optical flux, P (dBm) = 10 Log [P (μW)/1000 μW].
- Measured at the end of the fiber optic cable with large area detector.
- R_L is open.
- Pulsed LED operation at $I_F > 80$ mA will cause increased link t_{PLH} propagation delay time. This extended t_{PLH} time contributes to increased pulse width distortion of the receiver output signal.

1 MBd Link

(High Performance HFBR-15X2Z/25X2Z, Standard HFBR-15X4Z/25X4Z)

System Performance Under recommended operating conditions unless otherwise specified.

	Parameter	Symbol	Min.	Typ.	Max.	Units	Conditions	Ref.
High Performance 1 MBd	Data Rate		dc		1	MBd	$BER \leq 10^{-9}$, PRBS:2 ⁷ -1	
	Link Distance (Standard Cable)	ℓ	39 47	70		m m	$I_{Fdc} = 60$ mA $I_{Fdc} = 60$ mA, 25°C	Fig. 14 Notes 1, 3, 4
	Link Distance (Improved Cable)	ℓ	45 56	78		m m	$I_{Fdc} = 60$ mA $I_{Fdc} = 60$ mA, 25°C	Fig. 15 Notes 1, 3, 4
	Propagation Delay	t_{PLH} t_{PHL}		180 100	250 140	ns ns	$R_L = 560 \Omega$, $C_L = 30$ pF $I = 0.5$ metre $P_R = -24$ dBm	Fig. 16, 18 Notes 2, 4
	Pulse Width Distortion $t_{PLH} - t_{PHL}$	t_D		80		ns	$P_R = -24$ dBm $R_L = 560 \Omega$, $C_L = 30$ pF	Fig. 16, 17 Note 4

	Parameter	Symbol	Min.	Typ.	Max.	Units	Conditions	Ref.
Standard 1 MBd	Data Rate		dc		1	MBd	$BER \leq 10^{-9}$, PRBS:2 ⁷ -1	
	Link Distance (Standard Cable)	ℓ	8 17	43		m m	$I_{Fdc} = 60$ mA $I_{Fdc} = 60$ mA, 25°C	Fig. 12 Notes 1, 3, 4
	Link Distance (Improved Cable)	ℓ	10 19	48		m m	$I_{Fdc} = 60$ mA $I_{Fdc} = 60$ mA, 25°C	Fig. 13 Notes 1, 3, 4
	Propagation Delay	t_{PLH} t_{PHL}		180 100	250 140	ns ns	$R_L = 560 \Omega$, $C_L = 30$ pF $I = 0.5$ metre $P_R = -20$ dBm	Fig. 16, 18 Notes 2, 4
	Pulse Width Distortion $t_{PLH} - t_{PHL}$	t_D		80		ns	$P_R = -20$ dBm $R_L = 560 \Omega$, $C_L = 30$ pF	Fig. 16, 17 Note 4

Notes:

- For $I_{FPK} > 80$ mA, the duty factor must be such as to keep $I_{Fdc} \leq 80$ mA. In addition, for $I_{FPK} > 80$ mA, the following rules for pulse width apply:
 $I_{FPK} \leq 160$ mA: Pulse width ≤ 1 ms
 $I_{FPK} > 160$ mA: Pulse width ≤ 1 μ S, period ≥ 20 μ S.
- The propagation delay for one meter of cable is typically 5 ns.
- Estimated typical link life expectancy at 40°C exceeds 10 years at 60 mA.
- Pulsed LED operation at $I_{FPK} > 80$ mA will cause increased link t_{PLH} propagation delay time. This extended t_{PLH} time contributes to increased pulse width distortion of the receiver output signal.

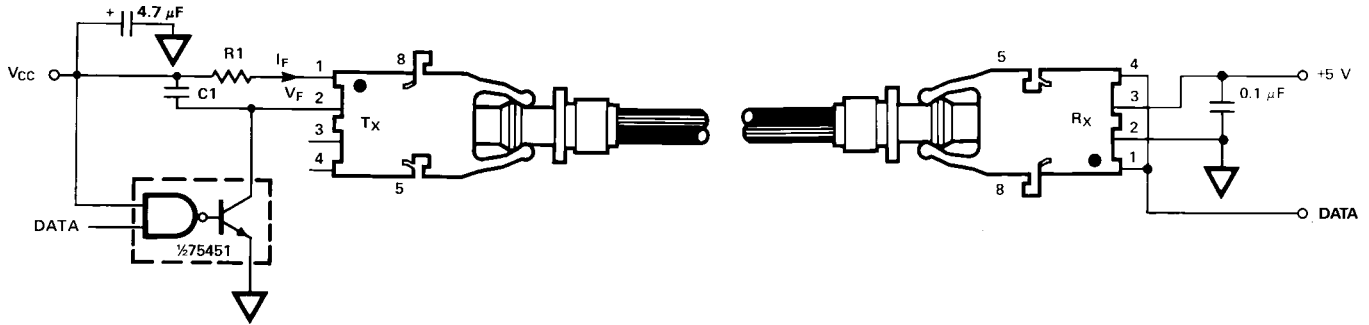

Figure 11. Required 1 MbD interface circuit

The HFBR-25X2Z receiver can not be overdriven when using the required interface circuit shown in Figure 11.

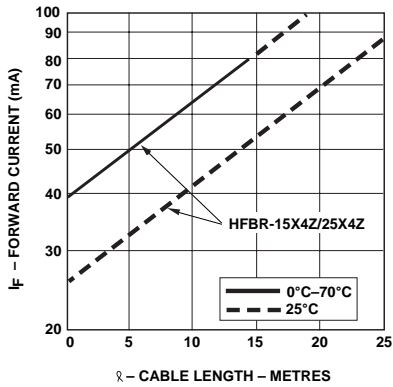

Figure 12. Guaranteed system performance for the HFBR-15X4Z/25X4Z link with standard cable.

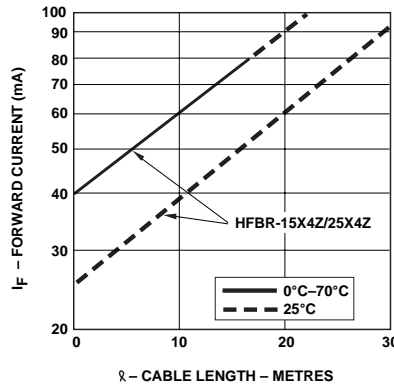

Figure 13. Guaranteed system performance for the HFBR-15X4Z/25X4Z link with improved cable.

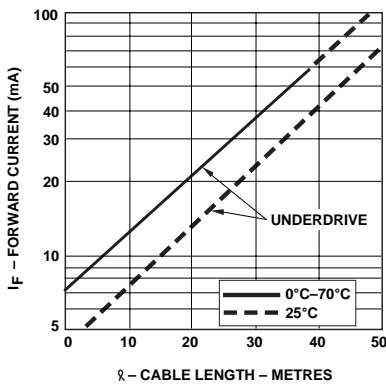

Figure 14. Guaranteed system performance for the HFBR-15X2Z/25X2Z link with standard cable.

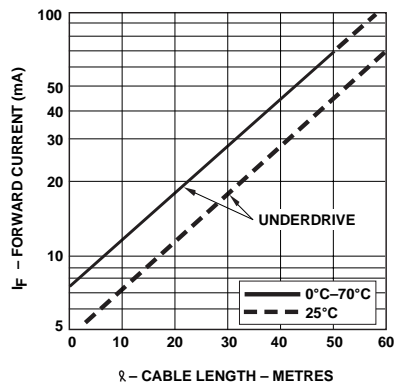

Figure 15. Guaranteed system performance for the HFBR-15X2Z/25X2Z link with improved cable.

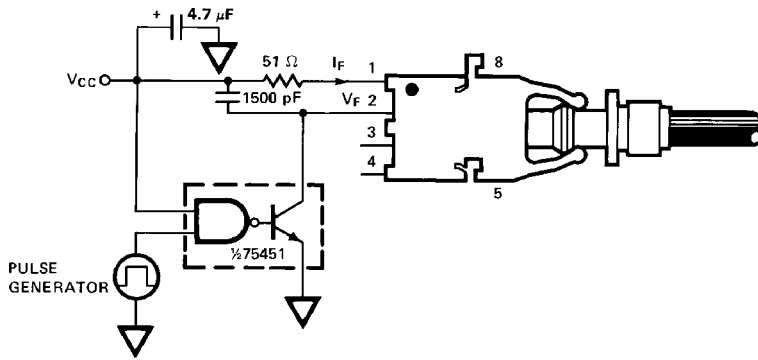

Figure 16. 1 Mb/s propagation delay test circuit.

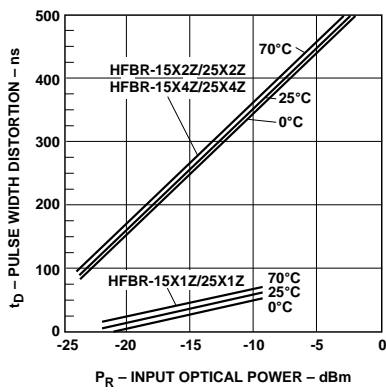

Figure 17. Pulse width distortion vs. optical power.

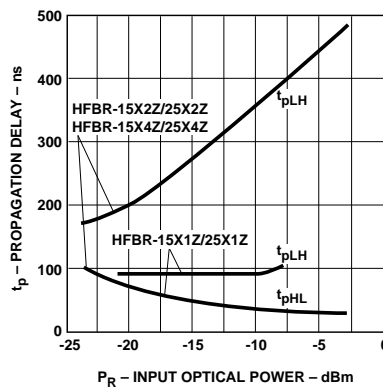

Figure 18. Typical link propagation delay vs. optical power.

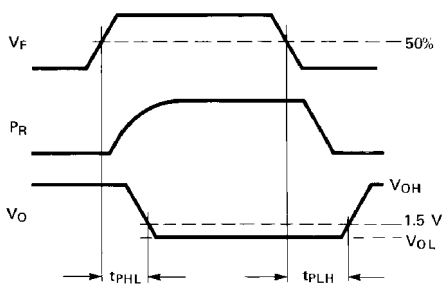
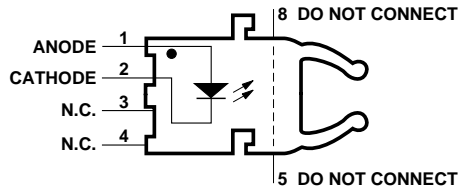

Figure 19. Propagation delay test waveforms.

HFBR-15X2Z/15X4Z Transmitters



Pin #	Function
1	Anode
2	Cathode
3	Open
4	Open
5	Do not connect
8	Do not connect

Note: Pins 5 and 8 are for mounting and retaining purposes only. Do not electrically connect these pins.

Absolute Maximum Ratings

Parameter	Symbol	Min.	Max.	Units	Reference
Storage Temperature	T_S	-40	+85	°C	
Operating Temperature	T_A	-40	+85	°C	
Lead Soldering Cycle	Temp.		260	°C	Note 1
	Time		10	sec	
Forward Input Current	I_{FPK}		1000	mA	Note 2, 3
	I_{Fdc}		80		
Reverse Input Voltage	V_{BR}		5	V	

Notes:

- 1.6 mm below seating plane.
- Recommended operating range between 10 and 750 mA.
- 1 μ s pulse, 20 μ s period.

All HFBR-15XXZ LED transmitters are classified as IEC 825-1 Accessible Emission Limit (AEL) Class 1 based upon the current proposed draft scheduled to go into effect on January 1, 1997. AEL Class 1 LED devices are considered eye safe. Contact your Avago sales representative for more information.

Transmitter Electrical/Optical Characteristics 0°C to 70°C unless otherwise specified.

For forward voltage and output power vs. drive current graphs.

Parameter	Symbol	Min.	Typ.	Max.	Units	Conditions	Ref.
Transmitter Output	HFBR-15X2Z	P_T	-13.6	-4.5	dBm	$I_{Fdc} = 60$ mA $I_{Fdc} = 60$ mA, 25°C	
			-11.2	-5.1			
Optical Power	HFBR-15X4Z	P_T	-17.8	-4.5	dBm	$I_{Fdc} = 60$ mA $I_{Fdc} = 60$ mA, 25°C	
			-15.5	-5.1			
Output Optical Power Temperature Coefficient	$\Delta P_T / \Delta T$		-0.85		%/°C		
Peak Emission Wavelength	λ_{PK}		660		nm		
Forward Voltage	V_F	1.45	1.67	2.02	V	$I_{Fdc} = 60$ mA	
Forward Voltage Temperature Coefficient	$\Delta V_F / \Delta T$		-1.37		mV/°C		Fig. 11
Effective Diameter	D_T		1		mm		
Numerical Aperture	NA		0.5				
Reverse Input Breakdown Voltage	V_{BR}	5.0	11.0		V	$I_{Fdc} = 10$ μ A, $T_A = 25$ °C	
Diode Capacitance	C_O		86		pF	$V_F = 0$, $f = 1$ MHz	
Rise Time	t_r		80		ns	10% to 90%, $I_F = 60$ mA	Note 1
Fall Time	t_f		40		ns		

Note:

- Rise and fall times are measured with a voltage pulse driving the transmitter and a series connected 50 Ω load. A wide bandwidth optical to electrical waveform analyzer, terminated to a 50 Ω input of a wide bandwidth oscilloscope, is used for this response time measurement.

HFBR-25X2Z/25X4Z Receivers

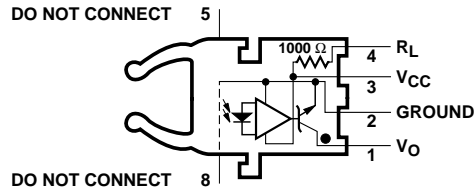

Pin #	Function
1	V_O
2	Ground
3	V_{CC}
4	R_L
5	Do not connect
8	Do not connect

Note: Pins 5 and 8 are for mounting and retaining purposes only. Do not electrically connect these pins.

Absolute Maximum Ratings

Parameter	Symbol	Min.	Max.	Units	Reference
Storage Temperature	T_S	-40	+85	°C	
Operating Temperature	T_A	-40	+85	°C	
Lead Soldering Cycle	Temp.		260	°C	Note 1
	Time		10	sec	
Supply Voltage	V_{CC}	-0.5	7	V	Note 2
Output Collector Current	I_{OAV}		25	mA	
Output Collector Power Dissipation	P_{OD}		40	mW	
Output Voltage	V_O	-0.5	18	V	
Pull-up Voltage	V_P	-5	V_{CC}	V	
Fan Out (TTL)	N		5		

Notes:

- 1.6 mm below seating plane.
- It is essential that a bypass capacitor 0.01 μ F be connected from pin 2 to pin 3 of the receiver. Total lead length between both ends of the capacitor and the pins should not exceed 20 mm.

Receiver Electrical/Optical Characteristics 0°C to 70°C, 4.75 V $\leq V_{CC} \leq 5.25$ V unless otherwise specified.

Parameter	Symbol	Min.	Typ.	Max.	Units	Conditions	Ref.
Receiver Optical Input Power Level Logic 0	HFBR-2522Z	$P_{R(L)}$	-24			$V_{OL} = 0$ V $I_{OL} = 8$ mA	Notes 1, 2, 3 Note 4
	HFBR-2524Z		-20				
Optical Input Power Level Logic 1	$P_{R(H)}$			-43	dBm	$V_{OH} = 5.25$ V $I_{OH} = \leq 250$ μ A	
High Level Output Current	I_{OH}		5	250	μ A	$V_O = 18$ V, $P_R = 0$	Note 5
Low Level Output Voltage	V_{OL}		0.4	0.5	V	$I_{OL} = 8$ mA $P_R = P_{R(L)MIN}$	Note 5
High Level Supply Current	I_{CCH}		3.5	6.3	mA	$V_{CC} = 5.25$ V, $P_R = 0$	Note 5
Low Level Supply Current	I_{CCL}		6.2	10	mA	$V_{CC} = 5.25$ V, $P_R = -12.5$ dBm	Note 5
Effective Diameter	D		1		mm		
Numerical Aperture	NA		0.5				
Internal Pull-up Resistor	R_L	680	1000	1700	Ω		

Notes:

- Measured at the end of the fiber optic cable with large area detector.
- Pulsed LED operation at $I_F > 80$ mA will cause increased link t_{PLH} propagation delay time. This extended t_{PLH} time contributes to increased pulse width distortion of the receiver output signal.
- The LED drive circuit of Figure 11 is required for 1 MBd operation of the HFBR-25X2Z/25X4Z.
- Optical flux, P (dBm) = 10 Log [P(μ W)/1000 μ W].
- R_L is open.

40 kBd Link

System Performance Under recommended operating conditions unless otherwise specified.

Parameter	Symbol	Min.	Typ.	Max.	Units	Conditions	Ref.
Data Rate		dc		40	kBd	BER $\leq 10^{-9}$, PRBS: $2^7 - 1$	
Link Distance (Standard Cable)	l	13 94	41 138		m m	$I_{Fdc} = 2 \text{ mA}$ $I_{Fdc} = 60 \text{ mA}$	Fig. 21 Note 1
Link Distance (Improved Cable)	l	15 111	45 154		m m	$I_{Fdc} = 2 \text{ mA}$ $I_{Fdc} = 60 \text{ mA}$	Fig. 22 Note 1
Propagation Delay	t_{PLH} t_{PHL}		4 2.5		μs μs	$R_L = 3.3 \text{ k}\Omega$, $C_L = 30 \text{ pF}$ $P_R = -25 \text{ dBm}$, 1 m fiber	Fig. 22, 25 Note 2
Pulse Width Distortion $t_{PLH} - t_{PHL}$	t_D			7	μs	$-39 \leq P_R \leq -14 \text{ dBm}$ $R_L = 3.3 \text{ k}\Omega$, $C_L = 30 \text{ pF}$	Fig. 23, 24

Notes:

1. Estimated typical link life expectancy at 40°C exceeds 10 years at 60 mA.
2. The propagation delay for one metre of cable is typically 5 ns.

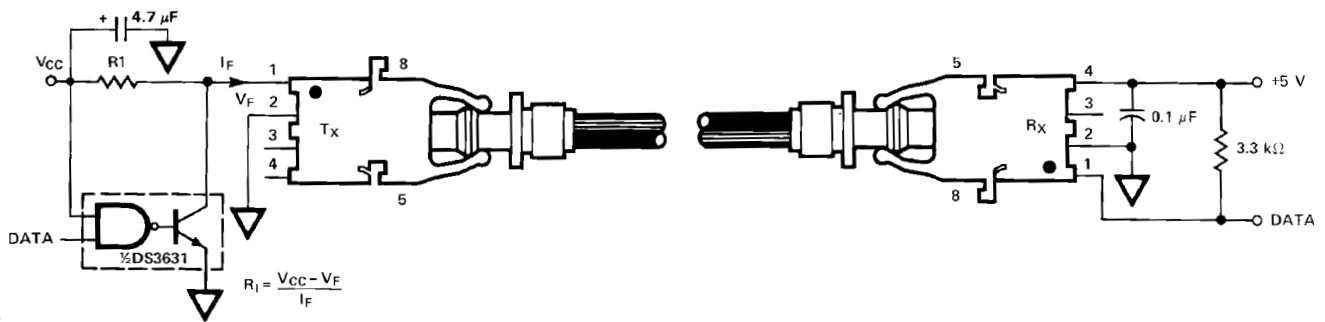

Figure 20. Typical 40 kBd interface circuit.

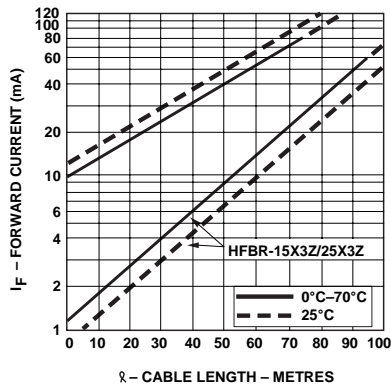

Figure 21. Guaranteed system performance with standard cable.

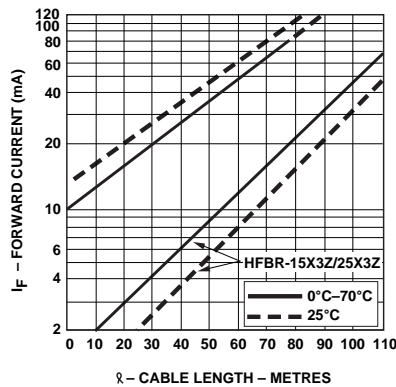

Figure 22. Guaranteed system performance with improved cable.

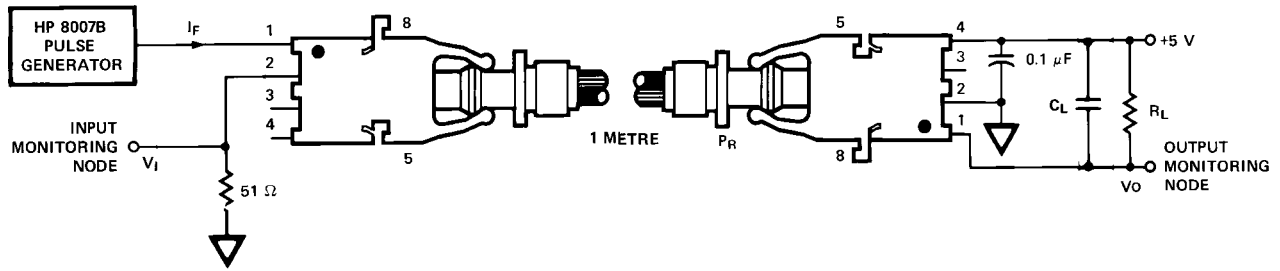

Figure 23. 40 kBd propagation delay test circuit.

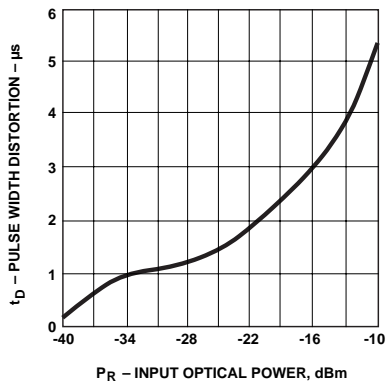

Figure 24. Typical link pulse width distortion vs. optical power.

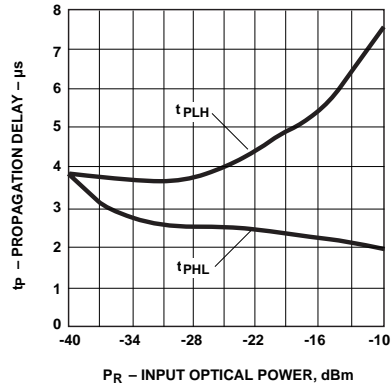

Figure 25. Typical link propagation delay vs. optical power.

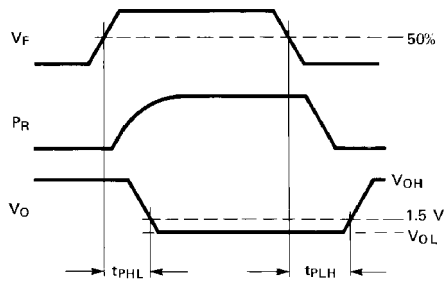
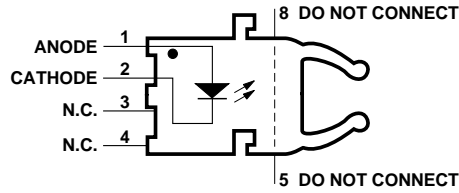

Figure 26. Propagation delay test waveforms.

HFBR-15X3Z Transmitter



Pin #	Function
1	Anode
2	Cathode
3	Open
4	Open
5	Do not connect
8	Do not connect

Note: Pins 5 and 8 are for mounting and retaining purposes only. Do not electrically connect these pins.

Absolute Maximum Ratings

Parameter	Symbol	Min.	Max.	Units	Reference
Storage Temperature	T_S	-40	+85	°C	
Operating Temperature	T_A	-40	+85	°C	
Lead Soldering Cycle	Temp.		260	°C	Note 1
	Time		10	sec	
Forward Input Current	I_{FPK}		1000	mA	Note 2, 3
	I_{Fdc}		80		
Reverse Input Voltage	V_{BR}		5	V	

Notes:

- 1.6 mm below seating plane.
- Recommended operating range between 10 and 750 mA.
- 1 μ s pulse, 20 μ s period.

All HFBR-15XXZ LED transmitters are classified as IEC 825-1 Accessible Emission Limit (AEL) Class 1 based upon the current proposed draft scheduled to go into effect on January 1, 1997. AEL Class 1 LED devices are considered eye safe. Contact your Avago sales representative for more information.

Transmitter Electrical/Optical Characteristics 0°C to 70°C unless otherwise specified.

For forward voltage and output power vs. drive current graphs.

Parameter	Symbol	Min.	Typ.	Max.	Units	Conditions	Ref.
Transmitter Output Optical Power	P_T	-11.2 -13.6 -35.5		-5.1 -4.5	dBm	$I_{Fdc} = 60$ mA, 25°C	Notes 3, 4 Fig. 9, 10
						$I_{Fdc} = 60$ mA	
						$I_{Fdc} = 2$ mA, 0-70°C	
Output Optical Power Temperature Coefficient	$\Delta P_T / \Delta T$		-0.85		%/°C		
Peak Emission Wavelength	λ_{PK}		660		nm		
Forward Voltage	V_F	1.45	1.67	2.02	V	$I_{Fdc} = 60$ mA	
Forward Voltage Temperature Coefficient	$\Delta V_F / \Delta T$		-1.37		mV/°C		Fig. 18
Effective Diameter	D		1		mm		
Numerical Aperture	NA		0.5				
Reverse Input Breakdown Voltage	V_{BR}	5.0	11.0		V	$I_{Fdc} = 10$ μ A, $T_A = 25$ °C	
Diode Capacitance	C_O		86		pF	$V_F = 0$, $f = 1$ MHz	
Rise Time	t_r		80		ns	10% to 90%, $I_F = 60$ mA	Note 1
Fall Time	t_f		40				

Note:

- Rise and fall times are measured with a voltage pulse driving the transmitter and a series connected 50 Ω load. A wide bandwidth optical to electrical waveform analyzer, terminated to a 50 Ω input of a wide bandwidth oscilloscope, is used for this response time measurement.

HFBR-25X3Z Receiver

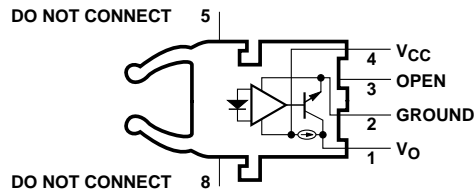

Pin #	Function
1	V ₀
2	Ground
3	Open
4	V _{CC}
5	Do not connect
8	Do not connect

Note: Pins 5 and 8 are for mounting and retaining purposes only. Do not electrically connect these pins.

Absolute Maximum Ratings

Parameter	Symbol	Min.	Max.	Units	Reference
Storage Temperature	T _S	-40	+85	°C	
Operating Temperature	T _A	-40	+85	°C	
Lead Soldering Cycle	Temp.		260	°C	Note 1
	Time		10	sec	
Supply Voltage	V _{CC}	-0.5	7	V	Note 2
Average Output Collector Current	I _O	-1	5	mA	
Output Collector Power Dissipation	P _{OD}		25	mW	
Output Voltage	V ₀	-0.5	7	V	

Notes:

- 1.6 mm below seating plane.
- It is essential that a bypass capacitor 0.01 μF be connected from pin 2 to pin 3 of the receiver.

Receiver Electrical/Optical Characteristics 0°C to 70°C, 4.5 V ≤ V_{CC} ≤ 5.5 V unless otherwise specified.

Parameter	Symbol	Min.	Typ.	Max.	Units	Conditions	Ref.
Input Optical Power Level Logic 0	P _{R(L)}	-39		-13.7	dBm	V ₀ = V _{OL} , I _{OL} = 3.2 mA	Notes 1, 2, 3
		-39		-13.3			
Input Optical Power Level Logic 1	P _{R(H)}			-53	dBm	V _{OH} = 5.5 V I _{OH} = ≤40 μA	Note 3
High Level Output Voltage	V _{OH}	2.4			V	I _O = -40 μA, P _R = 0 μW	
Low Level Output Voltage	V _{OL}			0.4	V	I _{OL} = 3.2 mA P _R = P _{R(L)MIN}	Note 4
High Level Supply Current	I _{CCH}		1.2	1.9	mA	V _{CC} = 5.5 V, P _R = 0 μW	
Low Level Supply Current	I _{CCL}		2.9	3.7	mA	V _{CC} = 5.5 V, P _R = P _{RL} (MIN)	Note 4
Effective Diameter	D		1		mm		
Numerical Aperture	NA		0.5				

Notes:

- Measured at the end of the fiber optic cable with large area detector.
- Optical flux, P (dBm) = 10 Log P(μW)/1000 μW.
- Because of the very high sensitivity of the HFBR-25X3Z, the digital output may switch in response to ambient light levels when a cable is not occupying the receiver optical port. The designer should take care to filter out signals from this source if they pose a hazard to the system.
- Including current in 3.3 k pull-up resistor.

For product information and a complete list of distributors, please go to our website: www.avagotech.com

Avago, Avago Technologies, and the A logo are trademarks of Avago Technologies, Pte. in the United States and other countries.
Data subject to change. Copyright © 2006 Avago Technologies Pte. All rights reserved.
5989-4630EN February 3, 2006

