

Part Number: [0008560108](#)
Status: **Active**
Overview: [KK@](#)
Description: 3.96mm (.156") Pitch KK@ Crimp Terminal 2578, 22-26 AWG, Bag, Brass, 0.51µm (20µ") Selective Gold (Au)

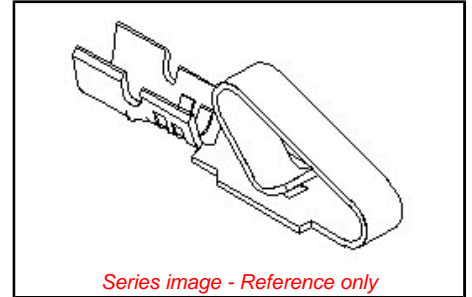

General

Product Family	Crimp Terminals
Series	2578
Overview	KK@
Product Name	KK@

Physical

Gender	Female
Material - Metal	Brass
Material - Plating Mating	Gold
Material - Plating Termination	Gold
Packaging Type	Bag
Plating min: Mating (µin)	15
Plating min: Mating (µm)	0.375
Plating min: Termination (µin)	2
Plating min: Termination (µm)	0.05
Termination Interface: Style	Crimp or Compression
Wire Insulation Diameter	1.65mm (.065") max.
Wire Size AWG	22
Wire Size AWG	24
Wire Size AWG	26
Wire Size mm ²	N/A

Material Info

Old Part Number	2578-(550)L
-----------------	-------------

EU RoHS
ELV and RoHS
Compliant

China RoHS



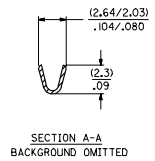
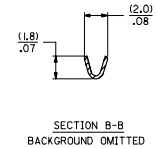
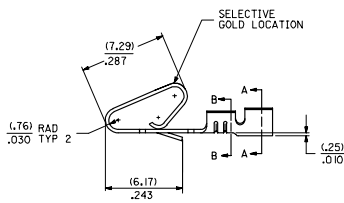
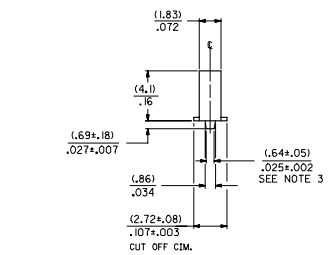
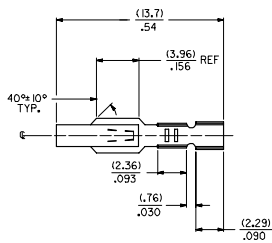
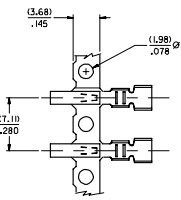
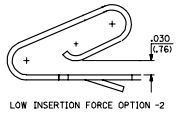
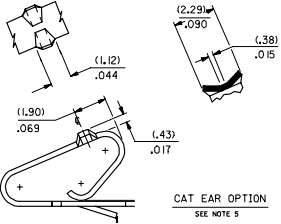

- NOTES:
1. CRIMP ACCEPTS 22 TO 26 GA. WIRE WITH (1.65)±.065 MAX INSULATION DIA.
 2. DIMENSIONS GIVEN ACROSS CENTERLINES ARE SYMMETRICAL ABOUT THOSE CENTERLINES WITHIN HALF THE TOTAL TOLERANCE.
 3. OPTIONAL DESIGN (.86±.05)±.034±.002
 4. TERMINAL CONFORMS TO PRODUCT SPEC. 08-50.
 5. CAT EAR OPTION TO BE USED WITH 41695 HOUSING ONLY.

MATERIAL CODE 2578 * * * * *

WINDING SPEC.
A=PER ES-339-A
BLANK=PER ES-339-B
L=LOOSE

PLATING CODE
(PER SDES-88)
*(P909) OVERALL HOT TIN DIP: 2.54 MICROMETERS MIN
(550) SELECT GOLD: 0.38 MICROMETERS MIN.
OVERALL GOLD FLASH: 0.05 MICROMETERS MIN.
OVERALL NICKEL UNDERPLATE: 0.76 MICROMETERS MIN.
(555) SELECT GOLD: 0.38 MICROMETERS MIN.
OVERALL NICKEL UNDERPLATE: 0.76 MICROMETERS MIN.

OPTIONS
BLANK=AS SHOWN
I=WITH CAT EARS
2=LOW INSERTION FORCE

*THE PRIMARY SHIPPING CARTON WILL BE LABELED "COMPLIANT TO ROHS DIRECTIVE 2002/95/EC AND ELV ANNEX II OF DIRECTIVE 2000/53/EC." CARTONS WITHOUT THIS LABEL MAY CONTAIN PRODUCT WITH TIN-LEAD PLATING.

ENTER DESCRIPTION EC NO. IEP2005-0928 DRN/BR/IN/OL 2004/11/16 CHK/OS/AN/EC 2004/11/02 APPROVED FOR RELEASE W	QUALITY SYMBOLS 	GENERAL TOLERANCES (UNLESS SPECIFIED) mm INCH		DRAWN BY PEREZ/AR	DATE 01/29/87	TITLE CRIMP TERMINAL (3.96)±.156 CENTERS 22 TO 26 GA WIRE	SCALE INCH	DESIGN UNITS INCH	THIRD ANGLE PROJECTION
		4 PLACES ±.005 3 PLACES ±.010 2 PLACES ±.025 1 PLACE ±.036	±.005 ±.010 ±.025 ±.036	APPROVED BY LENZ	DATE 01/29/87	MOLEX INCORPORATED	DOCUMENT NO. SD-2578	SHEET NO. 1 OF 2	
DRAFT WHERE APPLICABLE MUST REMAIN WITHIN DIMENSIONS		SEE CHART		THIS DRAWING CONTAINS INFORMATION THAT IS PROPRIETARY TO MOLEX INCORPORATED AND SHOULD NOT BE USED WITHOUT WRITTEN PERMISSION					

3.96mm (.156") Pitch Double-Sided Edge KK[®] Connector Terminals 4366 PC Crimp and Solder Eyelet

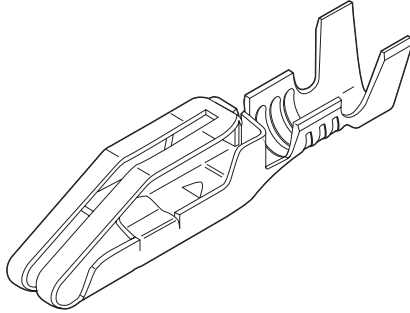

Features and Benefits

- Solder loop version available
- Anti-fishhooking feature prevents terminals from snagging
- Wire barrier prevents stripped wire from entering the contact area
- Coined outside edges prevent excess scoring of the solder pad surfaces
- Patented bifurcated contact area
- Anti-overstress feature

Reference Information

Packaging: Reel or bag
Use With: 4338
Designed In: Inches

Electrical

Voltage: 250V
Current: 5.0A
Contact Resistance: 20 milliohms max.
Dielectric Withstanding Voltage: 1500V
Insulation Resistance: 50,000 Megohms min.

Mechanical

Contact Retention to Housing: 8 lb min.
Wire Pull-Out Force: 20 lb for 18 AWG
(less for smaller wire)

Physical

Contact: Brass
Plating: See Table
Operating Temperature: 0 to +75°C

Order No.		Crimp Wire Size	Maximum Insulation Diameter	Engineering No.	Plating	Lead-free
Reel Form	Bag Form					
08-03-0303	08-03-0304	18-20	2.79 (.110)	4366	Tin	Yes
08-05-0301	08-05-0302			4366	Gold	

L 3.96mm (.156") Pitch KK[®] Crimp Terminal 2478/2578

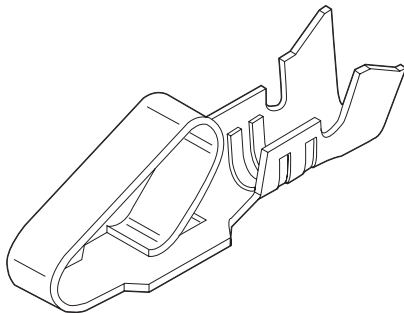

Features and Benefits

- Double cantilever design
- Single beam terminal is available for low insertion force 7821 Series (contact Molex)
- For low-level current and voltage, use Gold plating
- Phosphor Bronze is recommended for rated current
- Complete line of terminal crimping equipment available (see Application Tooling section of this catalog)

Reference Information

Product Specification: PS-08-50
Packaging: Reel or bag
Tooling Information: See crimp tooling section
UL File No.: E29179
CSA File No.: LR19980
Use With: 2139, 3069 and 41695
Designed In: Inches

Electrical

Voltage: 250V AC max.
Current: Max.

AWG	18	20	22	24	26
Phosphor Bronze	7.00A	6.25A	5.50A	5.00A	4.50A
Brass	5.00A	4.75A	4.50A	4.25A	4.00A

Contact Resistance: 6 milliohms max.
Dielectric Withstanding Voltage: 1500V AC
Insulation Resistance: 50K Megohms min.

Mechanical

Contact Insertion Force: 1.8kg (4 lb) max.
Contact Retention to Housing: 3.6kg (8 lb) min.
Wire Pull-Out Force: 20 lb max./18 AWG
Normal Force: 0.75kg (1.65 lb)
Durability: 25 cycles max.

Physical

Contact: Brass or Phosphor Bronze
Plating: See Table
Operating Temperature: Phosphor Bronze—0 to +75°C
Brass—0 to +50°C

Order No.						Wire Size AWG	Insulation OD	Series	Material	Lead-free
Tin Plating		Gold Plating No. 1		Gold Plating No. 2						
Reel	Bag	Reel	Bag	Reel	Bag					
08-52-0071	08-52-0072	08-58-0121	08-58-0122	08-65-0114	08-65-0115	18-20	2.79 (.110)	max. 2478	Phosphor Bronze	Yes
08-50-0105	08-50-0106	08-56-0105	08-56-0106	08-55-0103	08-55-0104	18-20	2.79 (.110)	max. 2478	Brass	
08-50-0133	08-50-0134	08-58-0125	08-58-0126	08-65-0116	08-65-0117	22-26	1.65 (.065)	max. 2578	Phosphor Bronze	
08-50-0107	08-50-0108	08-56-0107	08-56-0108	08-55-0105	08-55-0106	22-26	1.65 (.065)	max. 2578	Brass	

Recommended wire range assumes stranded wire
Plating No. 1: 20µm min. Gold in contact area with a flash overall
Plating No. 2: 15µm min. Gold in contact area only

