

REVISIONS				
REV	DESCRIPTION	ECN	BY	DATE
A	RELEASED	J05-0270	H.T	5/10/05

CAT. NO. & DIMENSIONS

NO. OF CONTACTS (n)	CAT. NO.		DIMENSIONS (NOTE1)		
	RIGHT ANGLE TYPE	STRAIGHT TYPE	A ± 0.3	B ± 0.1	C
4	HLW 4R-2C7LF	HLW 4S-2C7LF	6.6	5.12	3.0
5	HLW 5R-2C7LF	HLW 5S-2C7LF	7.6	6.12	4.0
6	HLW 6R-2C7LF	HLW 6S-2C7LF	8.6	7.12	5.0
7	HLW 7R-2C7LF	HLW 7S-2C7LF	9.6	8.12	6.0
8	HLW 8R-2C7LF	HLW 8S-2C7LF	10.6	9.12	7.0
9	HLW 9R-2C7LF	HLW 9S-2C7LF	11.6	10.12	8.0
10	HLW 10R-2C7LF	HLW 10S-2C7LF	12.6	11.12	9.0
11	HLW 11R-2C7LF	HLW 11S-2C7LF	13.6	12.12	10.0
12	HLW 12R-2C7LF	HLW 12S-2C7LF	14.6	13.12	11.0
13	HLW 13R-2C7LF	HLW 13S-2C7LF	15.6	14.12	12.0
14	HLW 14R-2C7LF	HLW 14S-2C7LF	16.6	15.12	13.0
15	HLW 15R-2C7LF	HLW 15S-2C7LF	17.6	16.12	14.0
16	HLW 16R-2C7LF	HLW 16S-2C7LF	18.6	17.12	15.0
17	HLW 17R-2C7LF	HLW 17S-2C7LF	19.6	18.12	16.0
18	HLW 18R-2C7LF	HLW 18S-2C7LF	20.6	19.12	17.0
19	HLW 19R-2C7LF	HLW 19S-2C7LF	21.6	20.12	18.0
20	HLW 20R-2C7LF	HLW 20S-2C7LF	22.6	21.12	19.0
21	HLW 21R-2C7LF	HLW 21S-2C7LF	23.6	22.12	20.0
22	HLW 22R-2C7LF	HLW 22S-2C7LF	24.6	23.12	21.0
23	HLW 23R-2C7LF	HLW 23S-2C7LF	25.6	24.12	22.0
24	HLW 24R-2C7LF	HLW 24S-2C7LF	26.6	25.12	23.0
25	HLW 25R-2C7LF	HLW 25S-2C7LF	27.6	26.12	24.0
26	HLW 26R-2C7LF	HLW 26S-2C7LF	28.6	27.12	25.0
27	HLW 27R-2C7LF	HLW 27S-2C7LF	29.6	28.12	26.0
28	HLW 28R-2C7LF	HLW 28S-2C7LF	30.6	29.12	27.0
29	HLW 29R-2C7LF	HLW 29S-2C7LF	31.6	30.12	28.0
30	HLW 30R-2C7LF	HLW 30S-2C7LF	32.6	31.12	29.0
31	HLW 31R-2C7LF	HLW 31S-2C7LF	33.6	32.12	30.0
32	HLW 32R-2C7LF	HLW 32S-2C7LF	34.6	33.12	31.0

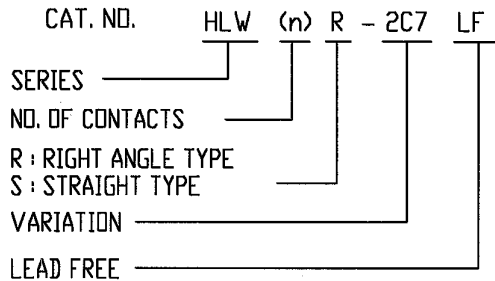

NOTES

1. SEE PART DRAWINGS FOR DIMENSIONS A~C.

SHEET INDEX	ISSUE	A														
	SH. NO.	1														
TOLERANCES UNLESS OTHERWISE SPECIFIED		DR		DATE		CUSTOMER COPY		TITLE CAT NO. TABLE FOR 1mm SPACING CONNECTOR (Cat. No. : HLW__R/S-2C7LF)								
LINEAR		ENGR		5/11/05												
ANGLES		CHK		5/13/05		THIRD ANGLE PROJ		PRODUCT FAMILY				CODE				
		APPD		5/13/05		UNIT		58JF				JP				
DO NOT SCALE PRINT		THIS INFORMATION IS CONFIDENTIAL AND IS DISCLOSED TO YOU ON CONDITION THAT NO FURTHER DISCLOSURE IS MADE BY YOU TO OTHER THAN FCI PERSONNEL WITHOUT WRITTEN AUTHORIZATION FROM FCI JAPAN K.K.										SCALE	SIZE	DWG. NO.	REV	SHEET
DF-140A REV A												mm	X	JSA 96403	A	1 of 1

REVISIONS				
REV	DESCRIPTION	ECN	BY	DATE
A	RELEASED	J05-0270	H.T	5/10/05
B	Added heat resistance	J05-0735	H.T	10/28/05

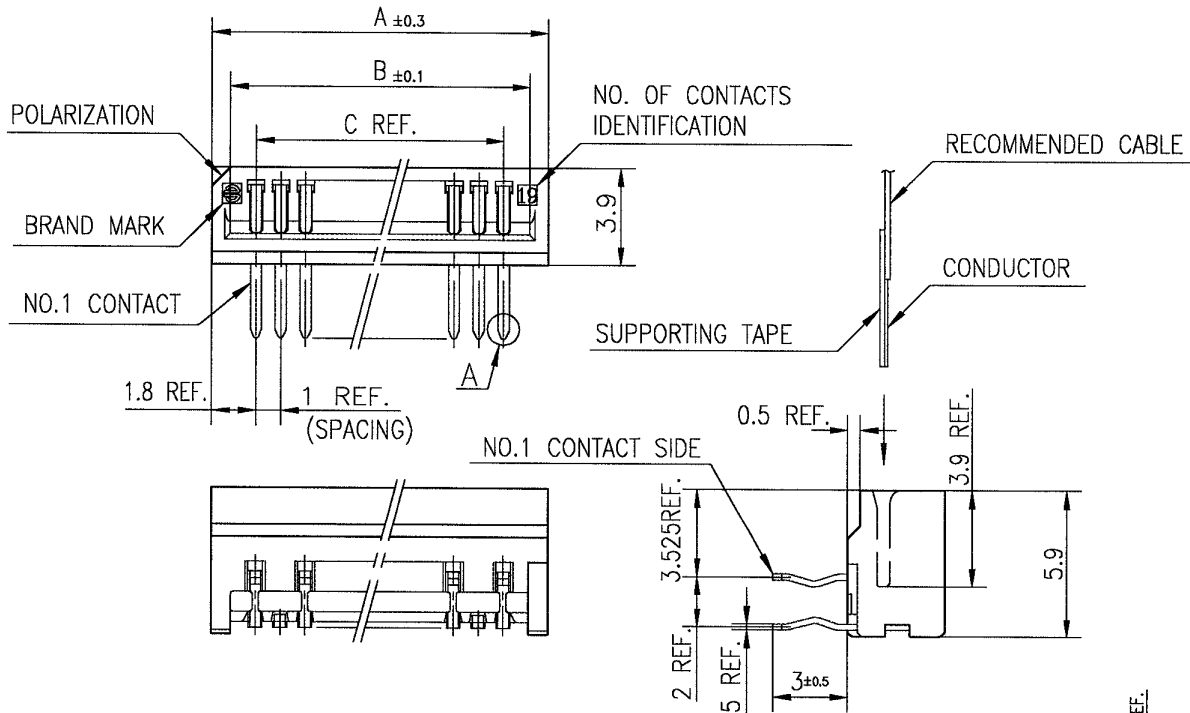

MATERIAL

INSULATOR : PBT RESIN GLASS REINFORCED (UL94V-0)

COLOR : BLACK

CONTACT : PHOSPHOR BRONZE

PLATING : TIN

NOTE

- 1.THIS PRODUCT IS RIGHT ANGLE TYPE CONNECTOR.
- 2.THIS PRODUCT MEETS EUROPEAN UNION DIRECTIVES AND OTHER COUNTRY REGULATIONS AS DESCRIBED IN GS-22-008.
- 3.THE HOUSING WILL WITHSTAND EXPOSURE TO 260°C PEAK TEMPERATURE FOR 10 SECONDS IN A WAVE SOLDER APPLICATION WITH A 1.6mm THICK CIRCUIT BOARD.

RECOMMENDED PC BOARD

THICKNESS : 1.2~1.6

HOLE PATTERN (COMPONENT SIDE)

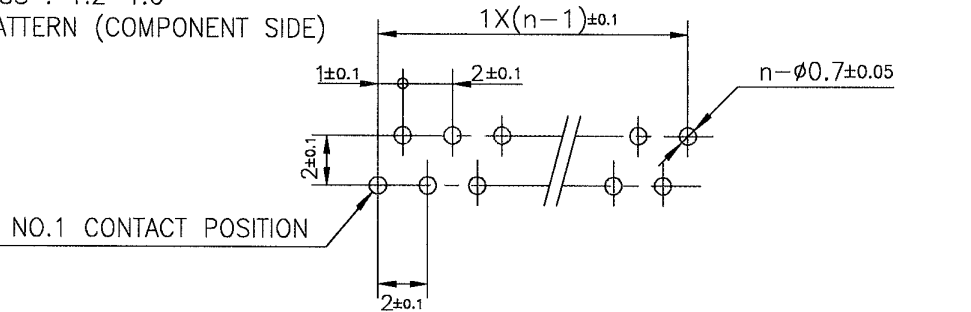

SHEET INDEX	ISSUE	B					A FCI
	SH NO.	1					
TOLERANCES UNLESS OTHERWISE SPECIFIED		DR	<i>M. Murayama</i>	DATE	10/27/05	CUSTOMER COPY	TITLE 1mm SPACING CONNECTOR FOR FPC/FFC (Cat. No. :HLW__R-2C7LF)
LINEAR	±0.2	ENGR	<i>H. Takahashi</i>	10/31/05	THIRD ANGLE PROJ		
ANGLES		CHK	<i>H. Takahashi</i>	10/31/05	UNIT	MM	PRODUCT FAMILY: 58JF
DO NOT SCALE PRINT		APPD	<i>S. Okada</i>	11/1/05	INCH		CODE JP
THIS INFORMATION IS CONFIDENTIAL AND IS DISCLOSED TO YOU ON CONDITION THAT NO FURTHER DISCLOSURE IS MADE BY YOU TO OTHER THAN FCI PERSONNEL WITHOUT WRITTEN AUTHORIZATION FROM FCI JAPAN K.K.		DF-140A REV A		SCALE	SIZE	DWG. NO.	REV SHEET
				X	A	JSA 96405	B 1 of 1

SC-HLW05 JSA96403

REVISIONS				
REV	DESCRIPTION	ECN	BY	DATE
A	RELEASED	J05-0270	H.T	5/10/05
B	Added heat resistance	J05-0735	H.T	10/28/05

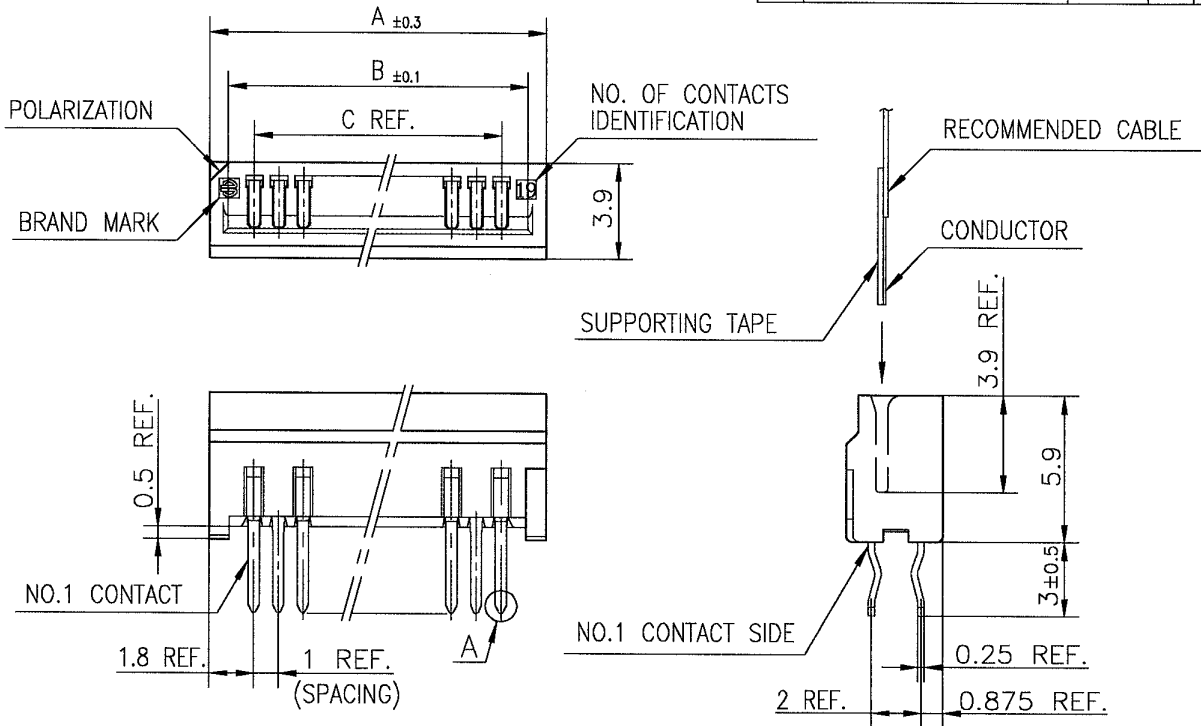

MATERIAL

INSULATOR : PBT RESIN GLASS REINFORCED (UL94V-0)
 COLOR : BLACK
 CONTACT : PHOSPHOR BRONZE
 PLATING : TIN

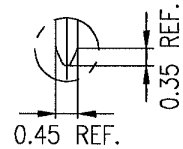

DETAIL A

- NOTE 1. THIS PRODUCT IS STRAIGHT TYPE CONNECTOR.
 2. THIS PRODUCT MEETS EUROPEAN UNION DIRECTIVES AND OTHER COUNTRY REGULATIONS AS DESCRIBED IN GS-22-008.
 3. THE HOUSING WILL WITHSTAND EXPOSURE TO 260°C PEAK TEMPERATURE FOR 10 SECONDS IN A WAVE SOLDER APPLICATION WITH A 1.6mm THICK CIRCUIT BOARD.

RECOMMENDED PC BOARD

THICKNESS : 1.2~1.6
 HOLE PATTERN (COMPONENT SIDE)

n : NO. OF CONTACTS

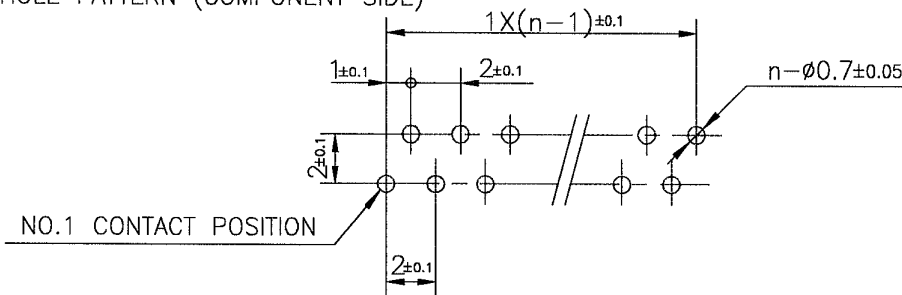

SHEET INDEX	ISSUE	B																						
	SH NO.	1																						
LINEAR	TOLERANCES UNLESS OTHERWISE SPECIFIED	±0.2	DR	<i>M. Motomura</i>	DATE	10/28/05	CUSTOMER COPY		TITLE	1mm SPACING CONNECTOR FOR FPC/FFC (Cat. No. :HLW__S-2C7LF)														
	ANGLES		ENGR	<i>H. Takahashi</i>		10/21/05	THIRD ANGLE PROJ		PRODUCT FAMILY	58JF														
				CHK	<i>H. Takahashi</i>		10/31/05	UNIT	MM INCH	CODE JP	B													
DD NOT SCALE PRINT		THIS INFORMATION IS CONFIDENTIAL AND IS DISCLOSED TO YOU ON CONDITION THAT NO FURTHER DISCLOSURE IS MADE BY YOU TO OTHER THAN FCI PERSONNEL WITHOUT WRITTEN AUTHORIZATION FROM FCI JAPAN K.K.																		SCALE	SIZE	DWG. NO.	REV	SHEET
DF-140A REV A		SC-HLW05 JSA96403																		∞	A	JSA 96406	B	1 of 1

REVISIONS				
REV	DESCRIPTION	ECN	BY	DATE
AA	Changed form	J05-0270	H.T	5/11/05

RECOMMENDED CABLE (FPC)

n : NO. OF CONDUCTORS

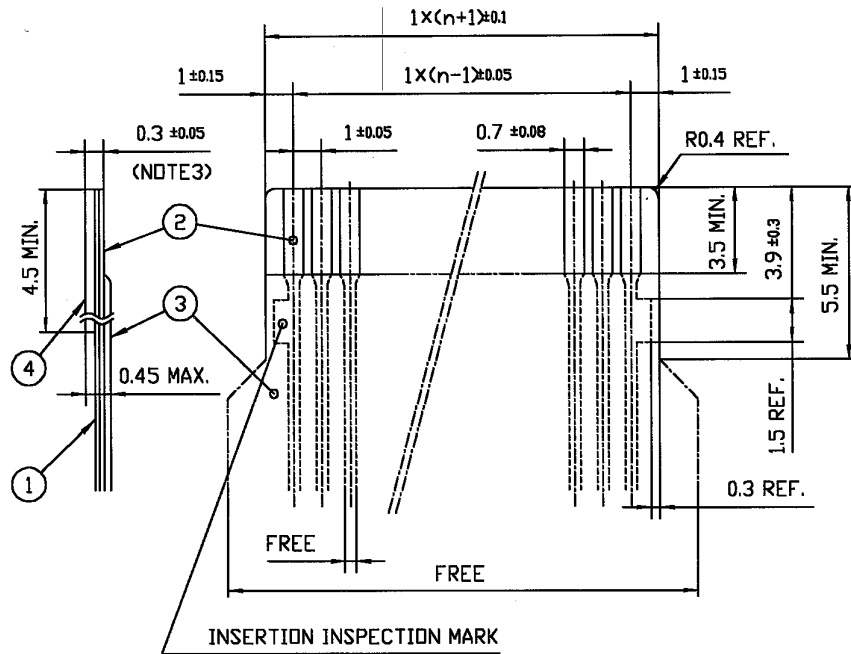

PT. NO.	DESCRIPTION	MATERIAL	THICKNESS (μm)
1	BASE FILM	POLYIMIDE OR POLYESTER OR EQUIVALENT	25
2	CONDUCTOR	COPPER FOIL (PLATING : SOLDER 1μm MIN.)	35
3	OVERLAY	POLYIMIDE OR POLYESTER OR EQUIVALENT	—
4	SUPPORTING TAPE	POLYESTER OR POLYIMIDE OR EQUIVALENT	188

NOTES

1. NO BURR AT EACH PORTION.
2. NO PEELING IN COMMON USE.
3. TOTAL THICKNESS LIMIT OF EACH MATERIAL (INCLUDING ADHESIVE AGENT) IS SPECIFIED.

SHEET INDEX	ISSUE	AA												
	SH NO.	1												
TOLERANCES UNLESS OTHERWISE SPECIFIED		DR	<i>T. Sasaki</i>	DATE	5/11/05	CUSTOMER COPY	TITLE							
LINEAR		ENGR	<i>H. Sasaki</i>	DATE	5/13/05		RECOMMENDED CABLE (FPC) (Cat. No. HLW__R/S-___)							
		CHK	<i>H. Sasaki</i>	DATE	5/13/05									
ANGLES		APPD	<i>M. Blazsarcana</i>	DATE	5/17/05	THIRD ANGLE PROJ	PRODUCT FAMILY				CODE			
DO NOT SCALE PRINT		THIS INFORMATION IS CONFIDENTIAL AND IS DISCLOSED TO YOU ON CONDITION THAT NO FURTHER DISCLOSURE IS MADE BY YOU TO OTHER THAN FCI PERSONNEL WITHOUT WRITTEN AUTHORIZATION FROM FCI JAPAN K.K.					UNIT	MM	INCH	SCALE	SIZE	DWG. NO.	REV	SHEET
DF-140A REV A							4/1	A		JSA93382	AA	OF		

REVISIONS				
REV	DESCRIPTION	ECN	BY	DATE
AA	Changed form	J05-0274	H.T	5/11/05

RECOMMENDED CABLE (FFC)

n : NO. OF CONDUCTORS

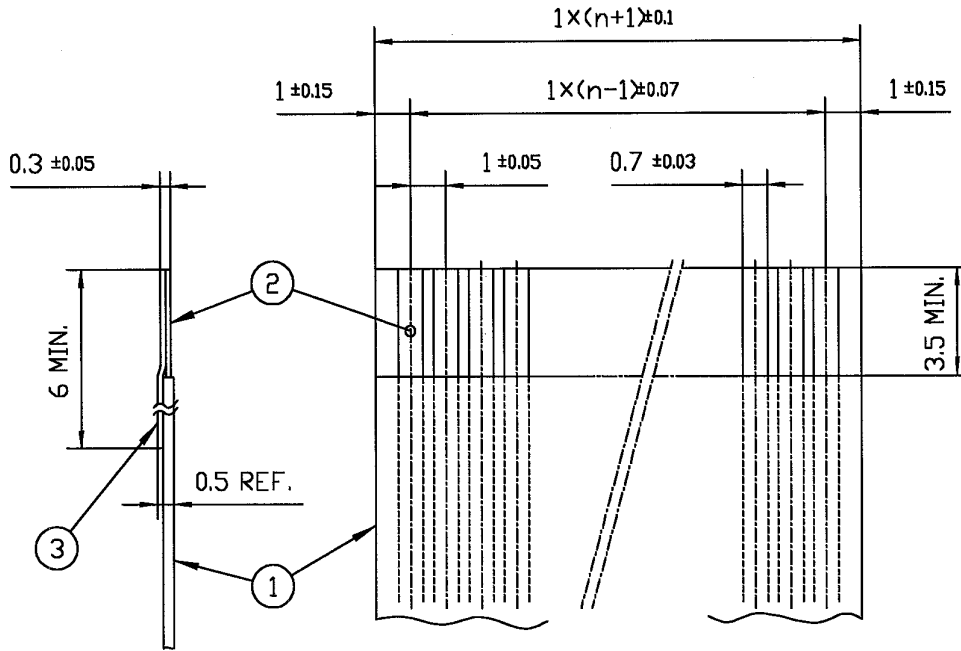

PT. NO.	DESCRIPTION	MATERIAL	NOTE
1	INSULATOR	FLAME RESISTING POLYESTER OR EQUIVALENT	_____
2	CONDUCTOR	COPPER FOIL	PLATING : TIN OR SOLDER 1μm MIN.
3	SUPPORTING TAPE	FLAME RESISTING POLYESTER OR EQUIVALENT	_____

NOTES

1. NO BURR AT EACH PORTION.
2. NO PEELING IN COMMON USE.

SHEET INDEX	ISSUE	AA										
	SH NO.	1										
LINEAR	TOLERANCES UNLESS OTHERWISE SPECIFIED		DR	<i>J. Sasaki</i>	DATE	5/11/05	CUSTOMER COPY	TITLE RECOMMENDED CABLE(FFC) (Cat. No. HLW__R/S-___)				
			ENGR	<i>H. Takahashi</i>	5/12/05							
			CHK	<i>H. Takahashi</i>	5/12/05	THIRD ANGLE PROJ						
ANGLES			APPD	<i>M. Hasegawa</i>	5/17/05	UNIT	MM	PRODUCT FAMILY				CODE JP
DO NOT SCALE PRINT		THIS INFORMATION IS CONFIDENTIAL AND IS DISCLOSED TO YOU ON CONDITION THAT NO FURTHER DISCLOSURE IS MADE BY YOU TO OTHER THAN FCI PERSONNEL WITHOUT WRITTEN AUTHORIZATION FROM FCI JAPAN K.K.					SCALE	SIZE	DWG. NO.	REV	SHEET	
DF-140A REV A							-	A	JSA 93383	AA	0F	

REVISIONS				
REV	DESCRIPTION	ECN	BY	DATE
A	RELEASED	J05-0270	H.T	5/10/05

CAT. NO. & DIMENSIONS

NO. OF CONTACTS (n)	CAT. NO.		DIMENSIONS (NOTE 1)		
	RIGHT ANGLE TYPE	STRAIGHT TYPE	A ± 0.3	B ± 0.1	C
4	HLW 4R-6C7LF	HLW 4S-6C7LF	6.6	5.12	3.0
5	HLW 5R-6C7LF	HLW 5S-6C7LF	7.6	6.12	4.0
6	HLW 6R-6C7LF	HLW 6S-6C7LF	8.6	7.12	5.0
7	HLW 7R-6C7LF	HLW 7S-6C7LF	9.6	8.12	6.0
8	HLW 8R-6C7LF	HLW 8S-6C7LF	10.6	9.12	7.0
9	HLW 9R-6C7LF	HLW 9S-6C7LF	11.6	10.12	8.0
10	HLW 10R-6C7LF	HLW 10S-6C7LF	12.6	11.12	9.0
11	HLW 11R-6C7LF	HLW 11S-6C7LF	13.6	12.12	10.0
12	HLW 12R-6C7LF	HLW 12S-6C7LF	14.6	13.12	11.0
13	HLW 13R-6C7LF	HLW 13S-6C7LF	15.6	14.12	12.0
14	HLW 14R-6C7LF	HLW 14S-6C7LF	16.6	15.12	13.0
15	HLW 15R-6C7LF	HLW 15S-6C7LF	17.6	16.12	14.0
16	HLW 16R-6C7LF	HLW 16S-6C7LF	18.6	17.12	15.0
17	HLW 17R-6C7LF	HLW 17S-6C7LF	19.6	18.12	16.0
18	HLW 18R-6C7LF	HLW 18S-6C7LF	20.6	19.12	17.0
19	HLW 19R-6C7LF	HLW 19S-6C7LF	21.6	20.12	18.0
20	HLW 20R-6C7LF	HLW 20S-6C7LF	22.6	21.12	19.0
21	HLW 21R-6C7LF	HLW 21S-6C7LF	23.6	22.12	20.0
22	HLW 22R-6C7LF	HLW 22S-6C7LF	24.6	23.12	21.0
23	HLW 23R-6C7LF	HLW 23S-6C7LF	25.6	24.12	22.0
24	HLW 24R-6C7LF	HLW 24S-6C7LF	26.6	25.12	23.0
25	HLW 25R-6C7LF	HLW 25S-6C7LF	27.6	26.12	24.0
26	HLW 26R-6C7LF	HLW 26S-6C7LF	28.6	27.12	25.0
27	HLW 27R-6C7LF	HLW 27S-6C7LF	29.6	28.12	26.0
28	HLW 28R-6C7LF	HLW 28S-6C7LF	30.6	29.12	27.0
29	HLW 29R-6C7LF	HLW 29S-6C7LF	31.6	30.12	28.0
30	HLW 30R-6C7LF	HLW 30S-6C7LF	32.6	31.12	29.0
31	HLW 31R-6C7LF	HLW 31S-6C7LF	33.6	32.12	30.0
32	HLW 32R-6C7LF	HLW 32S-6C7LF	34.6	33.12	31.0

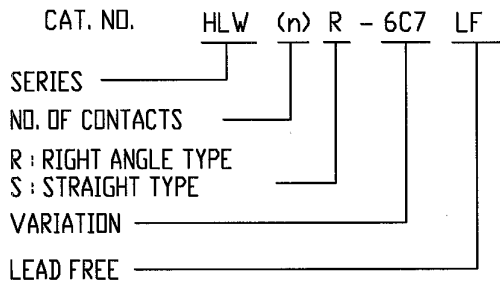

NOTES
1. SEE PART DRAWINGS FOR DIMENSIONS A~C.

SHEET INDEX	ISSUE	A																		
	SH NO.	1																		
TOLERANCES UNLESS OTHERWISE SPECIFIED			DR	<i>T. Sasaki</i>		DATE	5/11/05	CUSTOMER COPY												
LINEAR			ENGR	<i>H. Takahashi</i>		DATE	5/13/05	THIRD ANGLE PROJ												
			CHK	<i>H. Takahashi</i>		DATE	5/13/05													
ANGLES			APPD	<i>M. Hasegawa</i>		DATE	5/13/05	UNIT	MM											
DO NOT SCALE PRINT			THIS INFORMATION IS CONFIDENTIAL AND IS DISCLOSED TO YOU ON CONDITION THAT NO FURTHER DISCLOSURE IS MADE BY YOU TO OTHER THAN FCI PERSONNEL WITHOUT WRITTEN AUTHORIZATION FROM FCI JAPAN K.K.																	
DF-140A REV A																				



TITLE
CAT NO. TABLE FOR
1mm SPACING CONNECTOR
(Cat. No. : HLW__R/S-6C7LF)

PRODUCT FAMILY 58JF CODE JP

SCALE	SIZE	DWG. NO.	REV	SHEET
mm	X	JSA 96404	A	1 of 1

REVISIONS				
REV	DESCRIPTION	ECN	BY	DATE
A	RELEASED	J05-0270	H.T	5/10/05
B	Added heat resistance	J05-0735	H.T	10/28/05

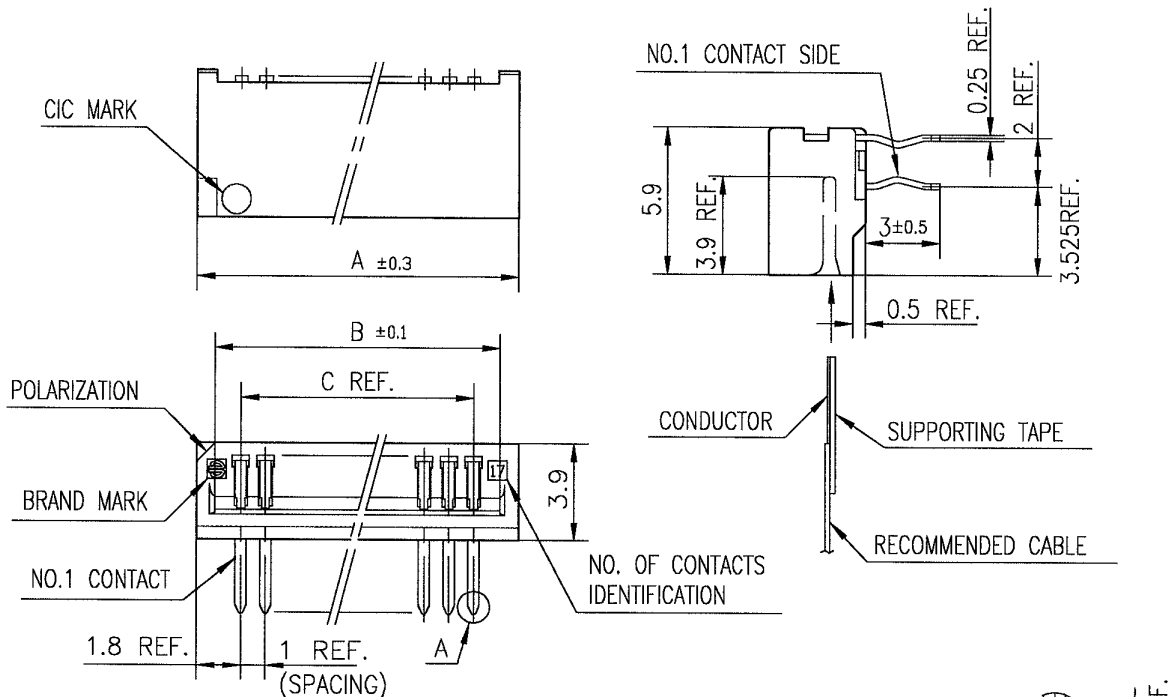

MATERIAL
 INSULATOR : PBT RESIN GLASS REINFORCED (UL94V-0)
 COLOR : BLACK
 CONTACT : PHOSPHOR BRONZE
 PLATING : TIN

- NOTE**
1. THIS PRODUCT IS RIGHT ANGLE TYPE CONNECTOR.
 2. THIS PRODUCT MEETS EUROPEAN UNION DIRECTIVES AND OTHER COUNTRY REGULATIONS AS DESCRIBED IN GS-22-008.
 3. THE HOUSING WILL WITHSTAND EXPOSURE TO 260°C PEAK TEMPERATURE FOR 10 SECONDS IN A WAVE SOLDER APPLICATION WITH A 1.6mm THICK CIRCUIT BOARD.

RECOMMENDED PC BOARD
 THICKNESS : 1.2~1.6
 HOLE PATTERN (COMPONENT SIDE)
 n : NO. OF CONTACTS

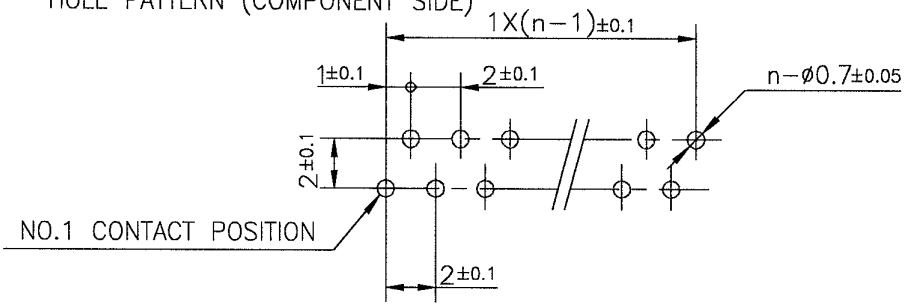

SHEET INDEX	ISSUE	B														
	SH NO.	1														
TOLERANCES UNLESS OTHERWISE SPECIFIED		DR	<i>M. Matsuyama</i>	DATE	10/28/05	CUSTOMER COPY		TITLE								
±0.2		ENGR	<i>H. Hatanaka</i>		10/21/05	THIRD ANGLE PROJ		1mm SPACING CONNECTOR FOR CIC (Cat. No. :HLW__R-6C7LF)								
LINEAR		CHK	<i>H. Hatanaka</i>		10/31/05	UNIT		PRODUCT FAMILY								
ANGLES		APPD	<i>S. Ochiai</i>		11/1/05	MM INCH		58JF								
DO NOT SCALE PRINT		THIS INFORMATION IS CONFIDENTIAL AND IS DISCLOSED TO YOU ON CONDITION THAT NO FURTHER DISCLOSURE IS MADE BY YOU TO OTHER THAN FCI PERSONNEL WITHOUT WRITTEN AUTHORIZATION FROM FCI JAPAN K.K.										SCALE	SIZE	DWG. NO.	REV	SHEET
DF-140A REV A												∞	A	JSA 96407	B	1 of 1

SC-HLW06 JSA96404

REVISIONS				
REV	DESCRIPTION	ECN	BY	DATE
A	RELEASED	J05-0270	H.T	5/10/05
B	Added heat resistance	J05-0735	H.T	10/28/05

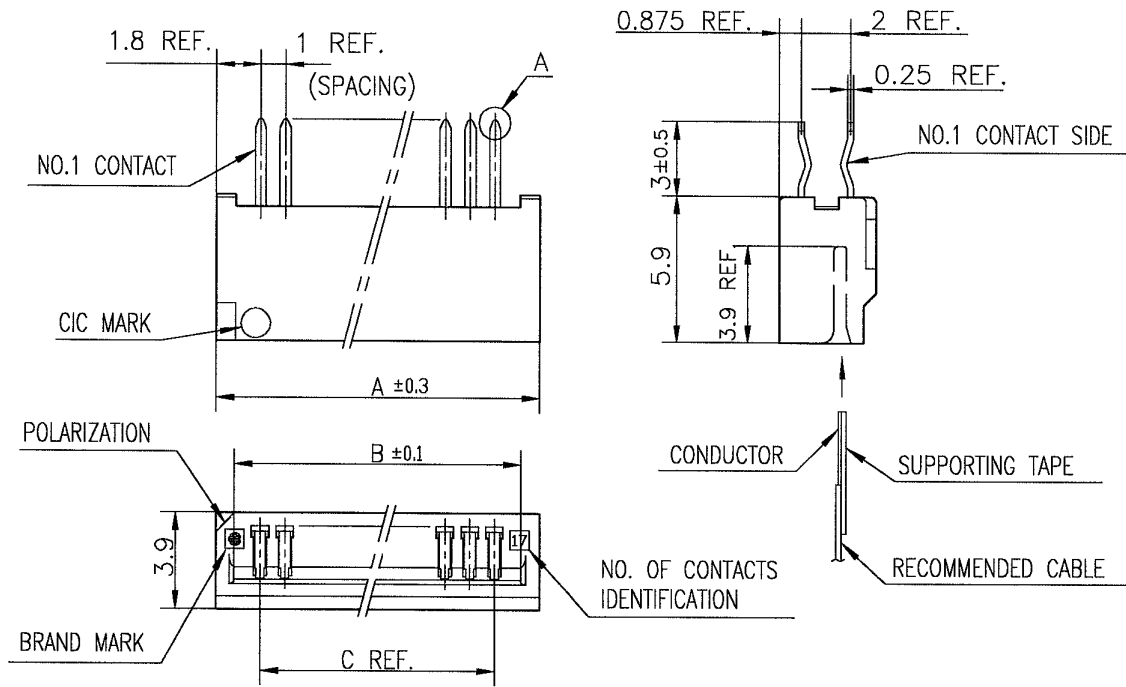

MATERIAL
 INSULATOR : PBT RESIN GLASS REINFORCED (UL94V-0)
 COLOR : BLACK
 CONTACT : PHOSPHOR BRONZE
 PLATING : TIN

NOTE
 1. THIS PRODUCT IS STRAIGHT TYPE CONNECTOR.
 2. THIS PRODUCT MEETS EUROPEAN UNION DIRECTIVES AND OTHER COUNTRY REGULATIONS AS DESCRIBED IN GS-22-008.
 3. THE HOUSING WILL WITHSTAND EXPOSURE TO 260°C PEAK TEMPERATURE FOR 10 SECONDS IN A WAVE SOLDER APPLICATION WITH A 1.6mm THICK CIRCUIT BOARD.

RECOMMENDED PC BORAD n : NO. OF CONTACTS

THICKNESS : 1.2~1.6
 HOLE PATTERN (COMPONENT SIDE)

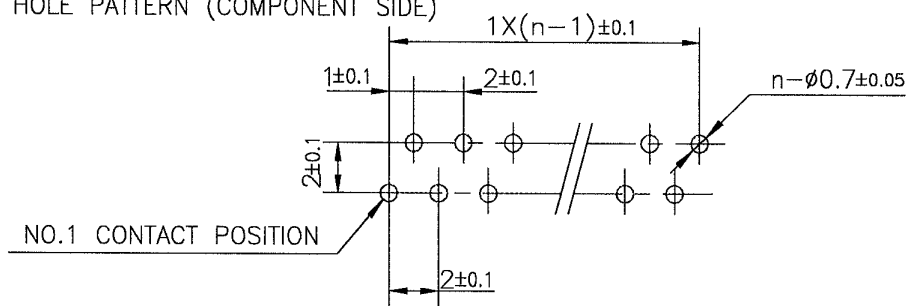

SHEET INDEX	ISSUE	B														FCI
	SH NO.	1														
LINEAR	TOLERANCES UNLESS OTHERWISE SPECIFIED	DR	<i>[Signature]</i>	DATE	10/28/05	CUSTOMER COPY		TITLE	1mm SPACING CONNECTOR FOR CIC (Cat. No. :HLW__S-6C7LF)							
	±0.2	ENGR	<i>[Signature]</i>		10/21/05	THIRD ANGLE PROJ		PRODUCT FAMILY	58JF				CODE JP			
		CHK	<i>[Signature]</i>		10/21/05	UNIT	MM INCH									
ANGLES		APPD	<i>[Signature]</i>		11/1/05											
DO NOT SCALE PRINT		THIS INFORMATION IS CONFIDENTIAL AND IS DISCLOSED TO YOU ON CONDITION THAT NO FURTHER DISCLOSURE IS MADE BY YOU TO OTHER THAN FCI PERSONNEL WITHOUT WRITTEN AUTHORIZATION FROM FCI JAPAN K.K.										SCALE	SIZE	DWG. NO.	REV	SHEET
DF-140A REV A		SC-HLW 06 JSA96404										X	A	JSA 96408	B	1 of 1

REVISIONS				
REV	DESCRIPTION	ECN	BY	DATE
AA	Changed form	J05-0270	H.T	5/11/05

RECOMMENDED CABLE (CIC)

n : NO. OF CONDUCTORS

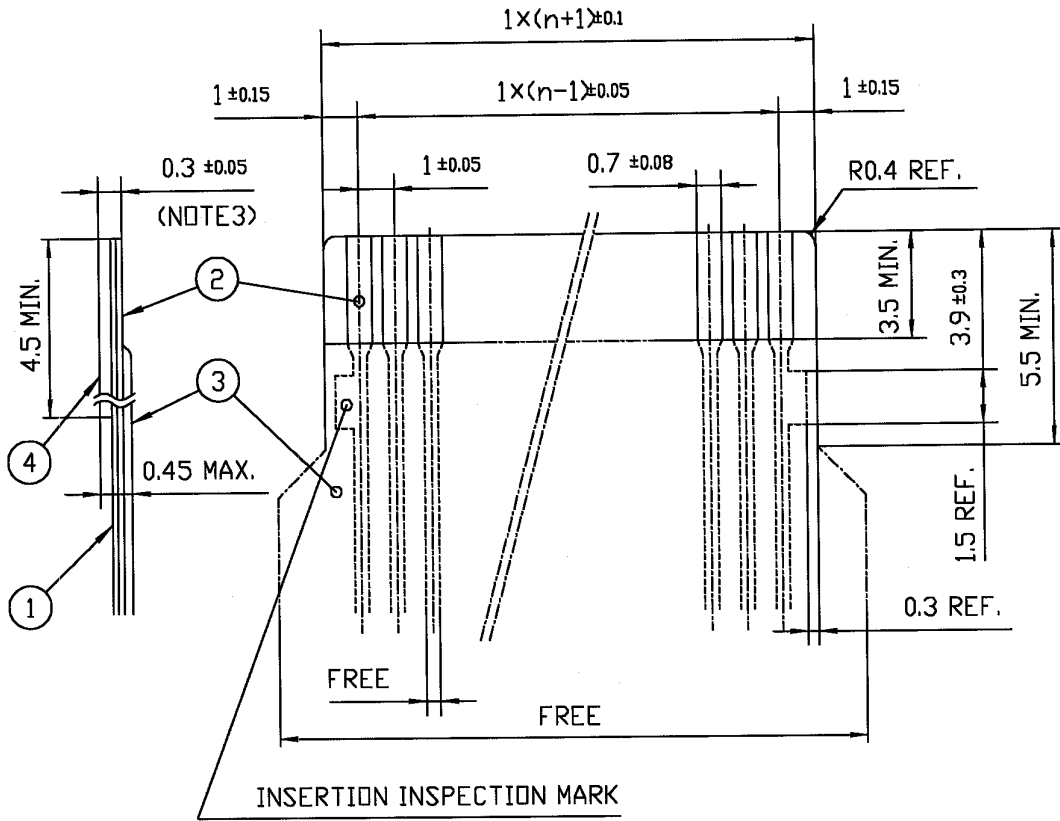

PT. NO.	DESCRIPTION	MATERIAL	THICKNESS (μm)	
1	BASE FILM	POLYESTER OR EQUIVALENT	75	25
2	CONDUCTOR	CARBON PASTE OVER SILVER PASTE	10 MIN.	
3	OVERLAY	POLYIMIDE OR POLYESTER OR EQUIVALENT	—	
4	SUPPORTING TAPE	POLYESTER OR POLYIMIDE OR EQUIVALENT	188	250

NOTES

1. NO BURR AT EACH PORTION.
2. NO PEELING IN COMMON USE.
3. TOTAL THICKNESS LIMIT OF EACH MATERIAL (INCLUDING ADHESIVE AGENT) IS SPECIFIED.

SHEET INDEX	ISSUE	AA									
	SH NO.	1									
TOLERANCES UNLESS OTHERWISE SPECIFIED		DR	<i>J. Sasaki</i>		DATE	5/11/05	CUSTOMER COPY	TITLE			
LINEAR		ENGR	<i>H. Sasaki</i>		DATE	5/13/05		RECOMMENDED CABLE(CIC)			
		CHK	<i>H. Sasaki</i>		DATE	5/13/05		(Cat. No. HLW__R/S-__)			
ANGLES		APPD	<i>M. Hasegawa</i>		DATE	5/13/05	THIRD ANGLE PROJ.	PRODUCT FAMILY		CODE JP	
							UNIT	58JF			
DO NOT SCALE PRINT		THIS INFORMATION IS CONFIDENTIAL AND IS DISCLOSED TO YOU ON CONDITION THAT NO FURTHER DISCLOSURE IS MADE BY YOU TO OTHER THAN FCI PERSONNEL WITHOUT WRITTEN AUTHORIZATION FROM FCI JAPAN K.K.					SCALE	SIZE	DWG. NO.	REV	SHEET
DF-140A REV A							5/1	A	JSA93626	AA	OF