

RECOMMENDED CABLE (FFC)

n : NO. OF CONDUCTORS

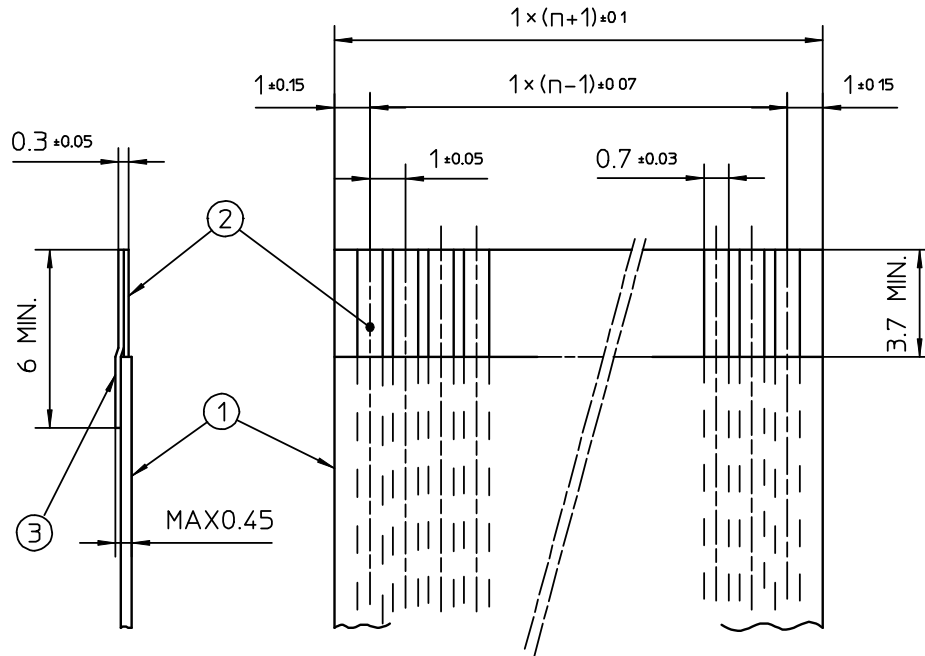

PT. NO.	DESCRIPTION	MATERIAL	NOTE
1	INSULATOR	FLAME RESISTING POLYESTER OR EQUIVALENT	_____
2	CONDUCTOR	COPPER FOIL	PLATING : TIN OR SOLDER 1μm MIN.
3	SUPPORTING TAPE	FLAME RESISTING POLYESTER OR EQUIVALENT	_____

NOTES

1. NO BURR AT EACH PORTION.
2. NO PEELING IN COMMON USE.

				SCALE	∞	RECOMMENDED CABLE	
				DIM. IN	mm	CAT NO.	
				DESIGNED		HFW__R-1/2__	
				DRAWN		DRAWING NO	REV
				CHECKED		JSA 93574	
				APPROVED		 DF-136 REV.B	
REV.	DATE	DESCRIPTION	DWN. APPD.	DATE			

RECOMMENDED CABLE (FPC)

n : NO. OF CONDUCTORS

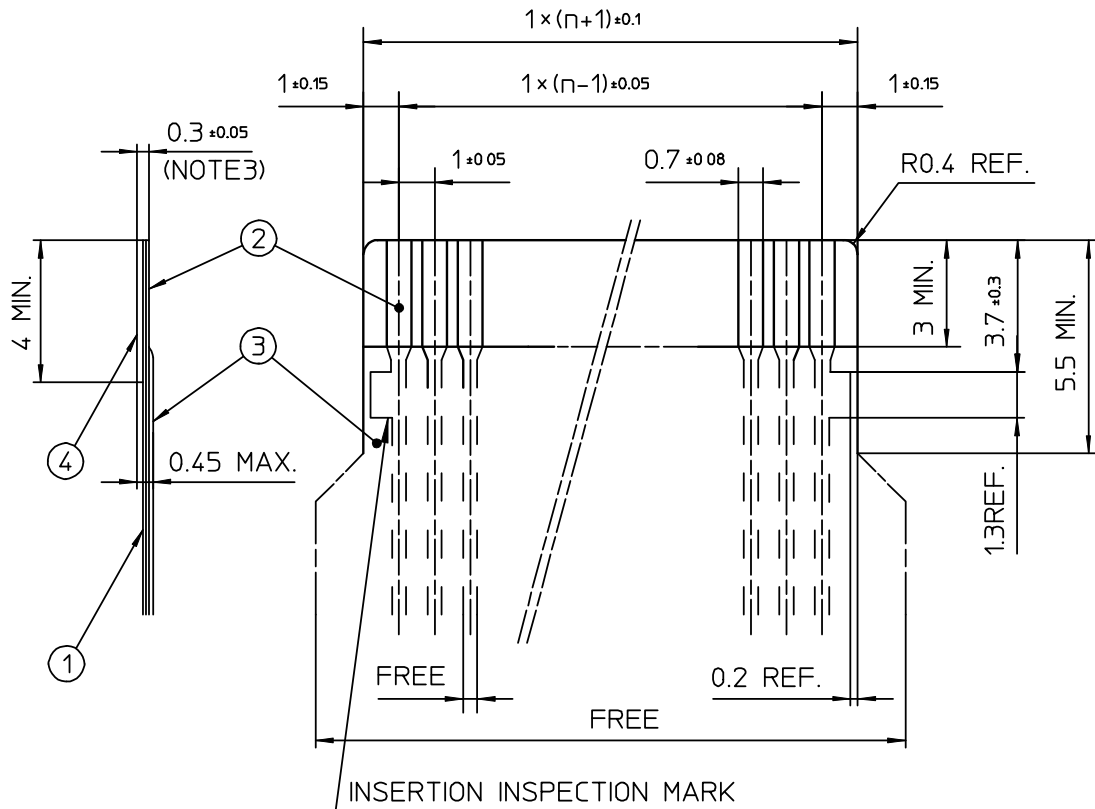

PT. NO.	DESCRIPTION	MATERIAL	THICKNESS (μm)
1	BASE FILM	POLYIMIDE OR POLYESTER OR EQUIVALENT	25
2	CONDUCTOR	COPPER FOIL (PLATING : SOLDER 1μm MIN.)	35
3	OVERLAY	POLYIMIDE OR POLYESTER OR EQUIVALENT	—
4	SUPPORTING TAPE	POLYESTER OR POLYIMIDE OR EQUIVALENT	188

NOTES

1. NO BURR AT EACH PORTION.
2. NO PEELING IN COMMON USE.
3. TOTAL THICKNESS LIMIT OF EACH MATERIAL (INCLUDING ADHESIVE AGENT) IS SPECIFIED.

				SCALE	∞	RECOMMENDED CABLE	
				DIM. IN	mm	CAT NO.	
				DESIGNED		HFW__R-1/2__	
				DRAWN		DRAWING NO	REV
				CHECKED		JSA 93573	
				APPROVED		 DF-136 REV.B	
REV.	DATE	DESCRIPTION	DWN.	APPD.	DATE		

TOLERANCES
UNLESS OTHERWISE SPECIFIED: ±0.2

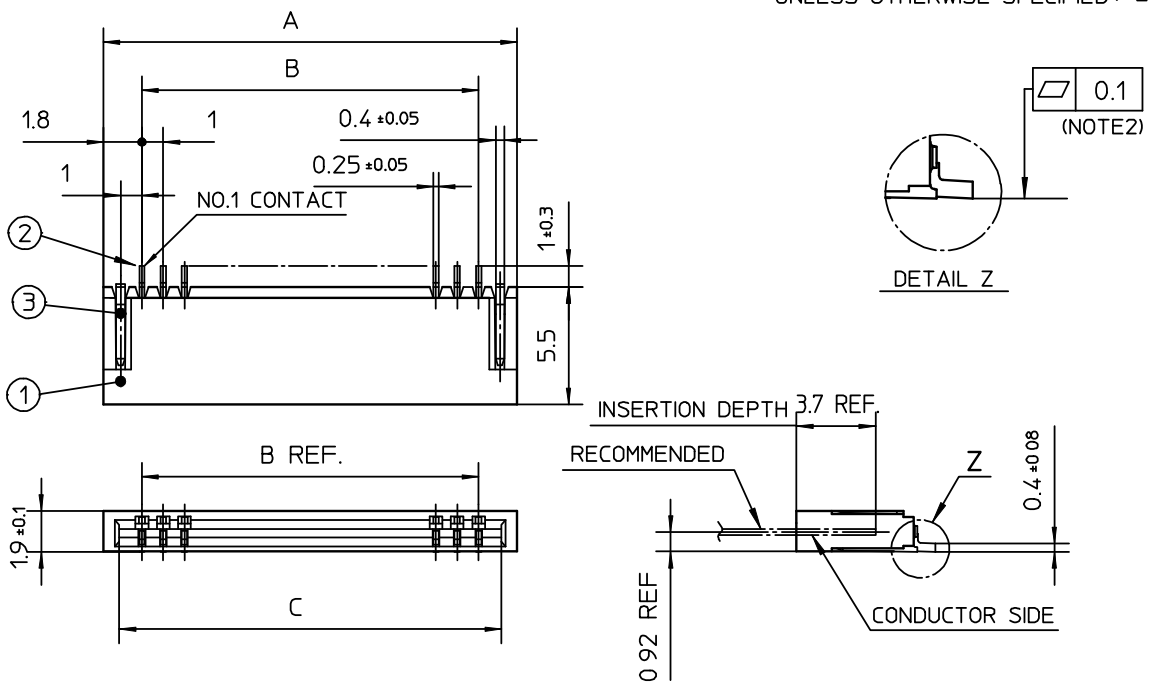

PT. NO.	PARTS NAME	MATERIAL	Q'TY	NOTE
1	HOUSING	PA6T RESIN GLASS REINFORCED (UL94V-0)	1	COLOR: BLACK
2	CONTACT	PHOSPHOR BRONZE	n	PLATING: TIN ALLOY
3	MOUNTING PLATE		2	

n : NO. OF CONTACTS

RECOMMENDED PC BOARD LAYOUT
(COMPONENT SIDE)

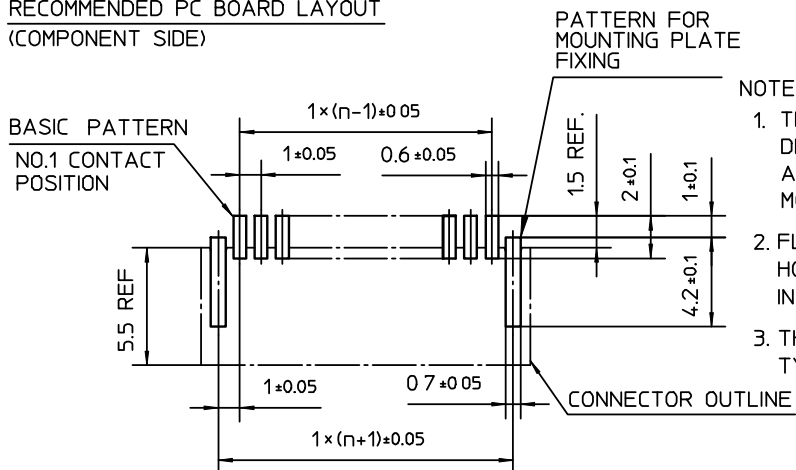

NOTES

1. THIS PRODUCT IS THE CONNECTOR DESIGNED TO TERMINATE FPC/FFC AND COPE WITH AUTOMATIC MOUNTING (SMT).
2. FLATNESS OF CONTACT TERMINAL FOR HOUSING MUST BE WITHIN TOLERANCE IN Z PORTION DETAILED DRAWING
3. THIS PRODUCT IS LOWER CONTACT TYPE CONNECTOR.

				SCALE	∞	1mm SPACING SURFACE MOUNT FPC/FFC CONNECTOR	
				DIM. IN	mm	CAT NO.	
				DESIGNED		HFW__R-1ST__	
				DRAWN		DRAWING NO	REV
				CHECKED		JSA 93571	
				APPROVED			
REV.	DATE	DESCRIPTION	DWN.	APPD.	DATE		

CAT. NO. & DIMENSIONS

(NOTE3)	NO. OF CONTACTS (n)	CAT. NO.	DIMENSIONS (NOTE2)		
			A ± 0.2	B ± 0.2	C ± 0.1
	4	HFW4R-1/2ST__	6.6	3	5.14
	5	HFW5R-1/2ST__	7.6	4	6.14
	6	HFW6R-1/2ST__	8.6	5	7.14
	7	HFW7R-1/2ST__	9.6	6	8.14
	8	HFW8R-1/2ST__	10.6	7	9.14
	9	HFW9R-1/2ST__	11.6	8	10.14
	10	HFW10R-1/2ST__	12.6	9	11.14
	11	HFW11R-1/2ST__	13.6	10	12.14
	12	HFW12R-1/2ST__	14.6	11	13.14
	13	HFW13R-1/2ST__	15.6	12	14.14
	14	HFW14R-1/2ST__	16.6	13	15.14
	15	HFW15R-1/2ST__	17.6	14	16.14
	16	HFW16R-1/2ST__	18.6	15	17.14
	17	HFW17R-1/2ST__	19.6	16	18.14
	18	HFW18R-1/2ST__	20.6	17	19.14
	19	HFW19R-1/2ST__	21.6	18	20.14
	20	HFW20R-1/2ST__	22.6	19	21.14
*	21	HFW21R-1/2ST__	23.6	20	22.14
	22	HFW22R-1/2ST__	24.6	21	23.14
	23	HFW23R-1/2ST__	25.6	22	24.14
	24	HFW24R-1/2ST__	26.6	23	25.14
	25	HFW25R-1/2ST__	27.6	24	26.14
	26	HFW26R-1/2ST__	28.6	25	27.14
	27	HFW27R-1/2ST__	29.6	26	28.14
*	28	HFW28R-1/2ST__	30.6	27	29.14
*	29	HFW29R-1/2ST__	31.6	28	30.14
	30	HFW30R-1/2ST__	32.6	29	31.14

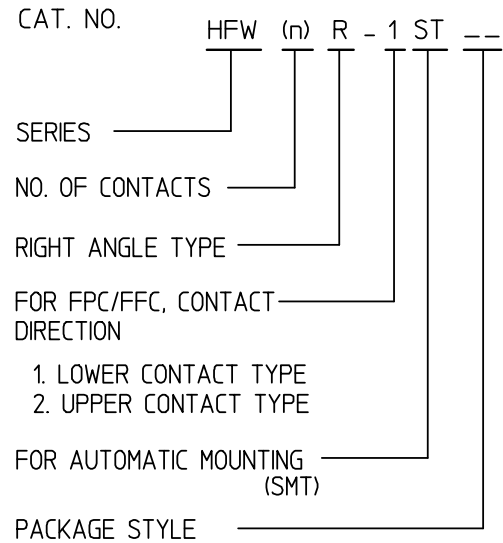

NOTES

1. THIS PRODUCT IS THE CONNECTOR DESIGNED TO TERMINATE FPC/FFC AND COPE WITH AUTOMATIC MOUNTING (SMT).
2. SEE PART DRAWINGS FOR DIMENSIONS A~C.
3. PLEASE CONSULT US IN CASE OF USING PARTS WITH * MARK.

					SCALE	∞	CAT. NO. TABLE FOR 1mm SPACING SMT CONNECTOR	
					DIM. IN	mm	CAT NO.	
					DESIGNED		HFW__R-1/2ST__	
					DRAWN		DRAWING NO	REV
					CHECKED		JSA 93575	
					APPROVED		 DF-136 REV.B	
REV.	DATE	DESCRIPTION	DWN.	APPD.	DATE			

CAT. NO. & DIMENSIONS

(NOTE4)	NO. OF CONTACTS (n)	CAT. NO. (NOTE2)	DIMENSIONS (NOTE3)		
			E ± 5	F ± 0.3	G ± 0.1
	4	HFW4R-1/2STE1	28.4	24	—
	5	HFW5R-1/2STE1	28.4	24	—
	6	HFW6R-1/2STE1	28.4	24	—
	7	HFW7R-1/2STE1	28.4	24	—
	8	HFW8R-1/2STE1	28.4	24	—
	9	HFW9R-1/2STE1	28.4	24	—
	10	HFW10R-1/2STE1	28.4	24	—
	11	HFW11R-1/2STE1	28.4	24	—
	12	HFW12R-1/2STE1	28.4	24	—
	13	HFW13R-1/2STE1	28.4	24	—
	14	HFW14R-1/2STE1	28.4	24	—
	15	HFW15R-1/2STE1	36.4	32	28.4
	16	HFW16R-1/2STE1	36.4	32	28.4
	17	HFW17R-1/2STE1	36.4	32	28.4
	18	HFW18R-1/2STE1	36.4	32	28.4
	19	HFW19R-1/2STE1	48.4	44	40.4
	20	HFW20R-1/2STE1	48.4	44	40.4
*	21	HFW21R-1/2STE1	48.4	44	40.4
	22	HFW22R-1/2STE1	48.4	44	40.4
	23	HFW23R-1/2STE1	48.4	44	40.4
	24	HFW24R-1/2STE1	48.4	44	40.4
	25	HFW25R-1/2STE1	48.4	44	40.4
	26	HFW26R-1/2STE1	48.4	44	40.4
	27	HFW27R-1/2STE1	48.4	44	40.4
*	28	HFW28R-1/2STE1	48.4	44	40.4
*	29	HFW29R-1/2STE1	48.4	44	40.4
	30	HFW30R-1/2STE1	60.4	56	52.4

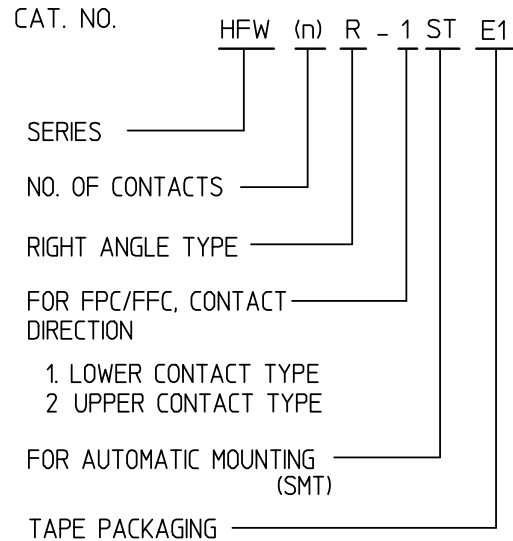

NOTES

1. THIS PRODUCT IS THE CONNECTOR DESIGNED TO TERMINATE FPC/FFC AND COPEs WITH AUTOMATIC MOUNTING (SMT).
2. THIS CATALOG NO. INDICATES PLASTIC TAPE PACKAGED CONNECTOR.
3. SEE PART DRAWINGS FOR DIMENSIONS E~G.
4. PLEASE CONSULT US IN CASE OF USING PARTS WITH * MARK.

					SCALE	×	CAT. NO. TABLE FOR PLASTIC TAPE PACKAGED 1mm SPACING SMT CONN. CAT NO. HFW__R-1/2STE1 DRAWING NO JSA 93589 REV
					DIM. IN	mm	
					DESIGNED		
					DRAWN		
					CHECKED		
					APPROVED		DF-136 REV.B
REV.	DATE	DESCRIPTION	DWN.	APPD.	DATE		



TOLERANCES
UNLESS OTHERWISE SPECIFIED : ±0.2

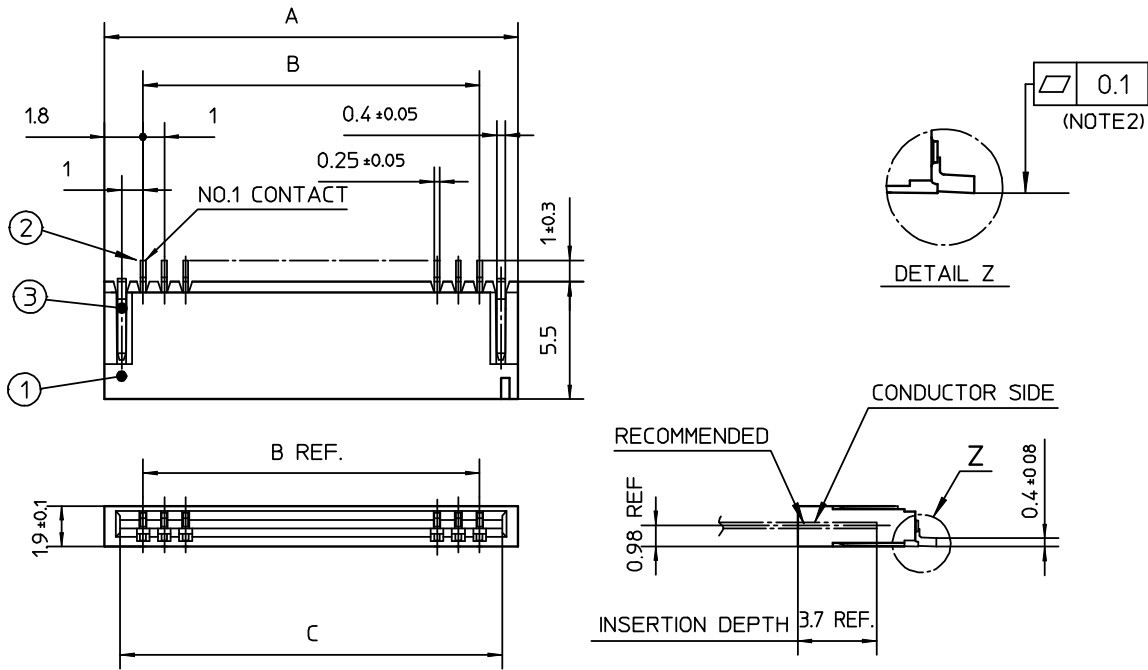

PT NO	PARTS NAME	MATERIAL	Q'TY	NOTE
1	HOUSING	PA6T RESIN GLASS REINFORCED (UL94V-0)	1	COLOR : BLACK
2	CONTACT	PHOSPHOR BRONZE	n	PLATING : TIN ALLOY
3	MOUNTING PLATE		2	

n : NO. OF CONTACTS

RECOMMENDED PC BOARD LAYOUT
(COMPONENT SIDE)

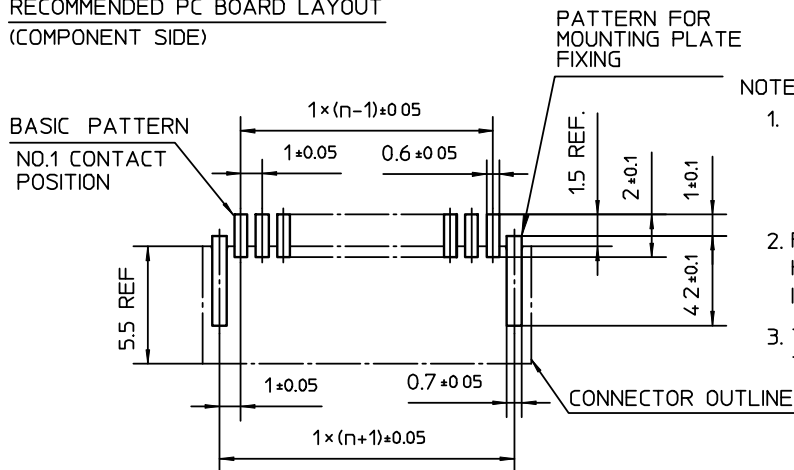

NOTES

1. THIS PRODUCT IS THE CONNECTOR DESIGNED TO TERMINATE FPC/FFC AND COPER WITH AUTOMATIC MOUNTING (SMT).
2. FLATNESS OF CONTACT TERMINAL FOR HOUSING MUST BE WITHIN TOLERANCE IN Z PORTION DETAILED DRAWING.
3. THIS PRODUCT IS UPPER CONTACT TYPE CONNECTOR.

				SCALE	∞	1mm SPACING SURFACE MOUNT FPC/FFC CONNECTOR	
				DIM. IN	mm	CAT NO.	
				DESIGNED		HFW__R-2ST__	
				DRAWN		DRAWING NO	REV
				CHECKED		JSA 93572	
				APPROVED			
REV.	DATE	DESCRIPTION	DWN.	APPD.	DATE		

CAT. NO. & DIMENSIONS

(NOTE 4)	NO OF CONTACTS (n)	CAT. NO. (NOTE 2)	DIMENSIONS (NOTE 3)		
			F ± 5	G ± 0.3	H ± 0.1
	4	HFW4S-2STE1	28.4	24	—
	5	HFW5S-2STE1	28.4	24	—
	6	HFW6S-2STE1	28.4	24	—
	7	HFW7S-2STE1	28.4	24	—
	8	HFW8S-2STE1	28.4	24	—
*	9	HFW9S-2STE1	28.4	24	—
	10	HFW10S-2STE1	28.4	24	—
	11	HFW11S-2STE1	28.4	24	—
	12	HFW12S-2STE1	28.4	24	—
	13	HFW13S-2STE1	28.4	24	—
	14	HFW14S-2STE1	36.4	32	28.4
	15	HFW15S-2STE1	36.4	32	28.4
	16	HFW16S-2STE1	36.4	32	28.4
	17	HFW17S-2STE1	36.4	32	28.4
	18	HFW18S-2STE1	48.4	44	40.4
	19	HFW19S-2STE1	48.4	44	40.4
	20	HFW20S-2STE1	48.4	44	40.4
	21	HFW21S-2STE1	48.4	44	40.4
	22	HFW22S-2STE1	48.4	44	40.4
	23	HFW23S-2STE1	48.4	44	40.4
	24	HFW24S-2STE1	48.4	44	40.4
	25	HFW25S-2STE1	48.4	44	40.4
	26	HFW26S-2STE1	48.4	44	40.4
	27	HFW27S-2STE1	48.4	44	40.4
	28	HFW28S-2STE1	48.4	44	40.4
	29	HFW29S-2STE1	60.4	56	52.4
	30	HFW30S-2STE1	60.4	56	52.4
*	31	HFW31S-2STE1	60.4	56	52.4
	32	HFW32S-2STE1	60.4	56	52.4
*	33	HFW33S-2STE1	60.4	56	52.4

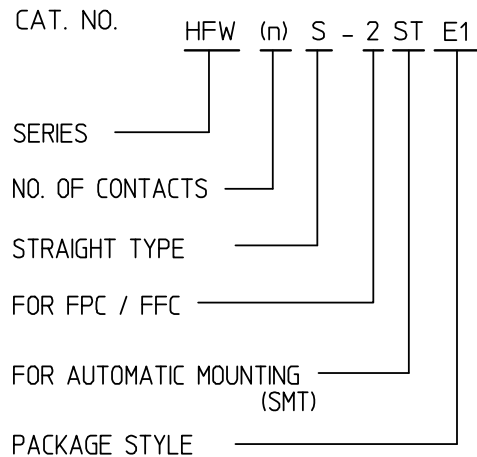

NOTES

1. THIS PRODUCT IS THE CONNECTOR DESIGNED TO TERMINATE FPC/FFC AND COPE WITH AUTOMATIC MOUNTING (SMT).
2. THIS CATALOG NO. INDICATES PLASTIC TAPE PACKAGED CONNECTOR.
3. SEE PART DRAWINGS FOR DIMENSIONS F-H
4. PLEASE CONSULT US IN CASE OF USING PARTS WITH * MARK.

				SCALE	∞	CAT NO. TABLE FOR PLASTIC TAPE PACKAGED 1mm SPACING SMT CONN.	
				DIM. IN	mm	CAT NO.	
				DESIGNED		HFW__S-2STE1	
				DRAWN		DRAWING NO	REV
				CHECKED		JSA 93584	
				APPROVED		 DF-136 REV.B	
REV.	DATE	DESCRIPTION	DWN.	APPD.	DATE		

CAT. NO. & DIMENSIONS

(NOTE 3)	NO. OF CONTACTS (n)	CAT. NO.	DIMENSIONS (NOTE2)				
			A ± 0.2	B ± 0.2	C ± 0.2	D ± 0.2	E ± 0.2
	4	HFW4S-2ST__	7	5.14	3	—	—
	5	HFW5S-2ST__	8	6.14	4	—	—
	6	HFW6S-2ST__	9	7.14	5	—	—
	7	HFW7S-2ST__	10	8.14	6	—	—
	8	HFW8S-2ST__	11	9.14	7	—	—
*	9	HFW9S-2ST__	12	10.14	8	0.35	7.3
	10	HFW10S-2ST__	13	11.14	9	0.35	8.3
	11	HFW11S-2ST__	14	12.14	10	1.35	7.3
	12	HFW12S-2ST__	15	13.14	11	1.35	8.3
	13	HFW13S-2ST__	16	14.14	12	2.35	7.3
	14	HFW14S-2ST__	17	15.14	13	2.35	8.3
	15	HFW15S-2ST__	18	16.14	14	3.35	7.3
	16	HFW16S-2ST__	19	17.14	15	3.35	8.3
	17	HFW17S-2ST__	20	18.14	16	4.35	7.3
	18	HFW18S-2ST__	21	19.14	17	4.35	8.3
	19	HFW19S-2ST__	22	20.14	18	5.35	7.3
	20	HFW20S-2ST__	23	21.14	19	5.35	8.3
	21	HFW21S-2ST__	24	22.14	20	6.35	7.3
	22	HFW22S-2ST__	25	23.14	21	6.35	8.3
	23	HFW23S-2ST__	26	24.14	22	7.35	7.3
	24	HFW24S-2ST__	27	25.14	23	7.35	8.3
	25	HFW25S-2ST__	28	26.14	24	8.35	7.3
	26	HFW26S-2ST__	29	27.14	25	8.35	8.3
	27	HFW27S-2ST__	30	28.14	26	9.35	7.3
	28	HFW28S-2ST__	31	29.14	27	9.35	8.3
	29	HFW29S-2ST__	32	30.14	28	10.35	7.3
	30	HFW30S-2ST__	33	31.14	29	10.35	8.3
*	31	HFW31S-2ST__	34	32.14	30	11.35	7.3
	32	HFW32S-2ST__	35	33.14	31	11.35	8.3
*	33	HFW33S-2ST__	36	34.14	32	12.35	7.3

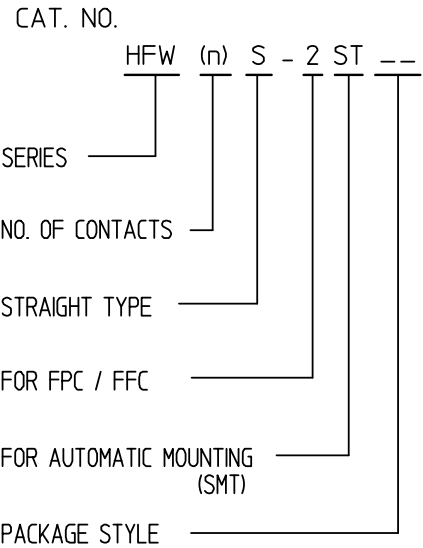

NOTES

1. THIS PRODUCT IS THE CONNECTOR DESIGNED TO TERMINATE FPC/FFC AND COPE WITH AUTOMATIC MOUNTING (SMT).
2. SEE PART DRAWINGS FOR DIMENSIONS A~E.
3. PLEASE CONSULT US IN CASE OF USING PARTS WITH * MARK.

				SCALE	∞	CAT NO. TABLE FOR 1mm SPACING SMT CONNECTOR	
				DIM. IN	mm	CAT NO.	
				DESIGNED		HFW__S-2ST__	
				DRAWN		DRAWING NO	REV
				CHECKED		JSA 93586	
				APPROVED		 DF-136 REV.B	
REV.	DATE	DESCRIPTION	DWN.	APPD.	DATE		

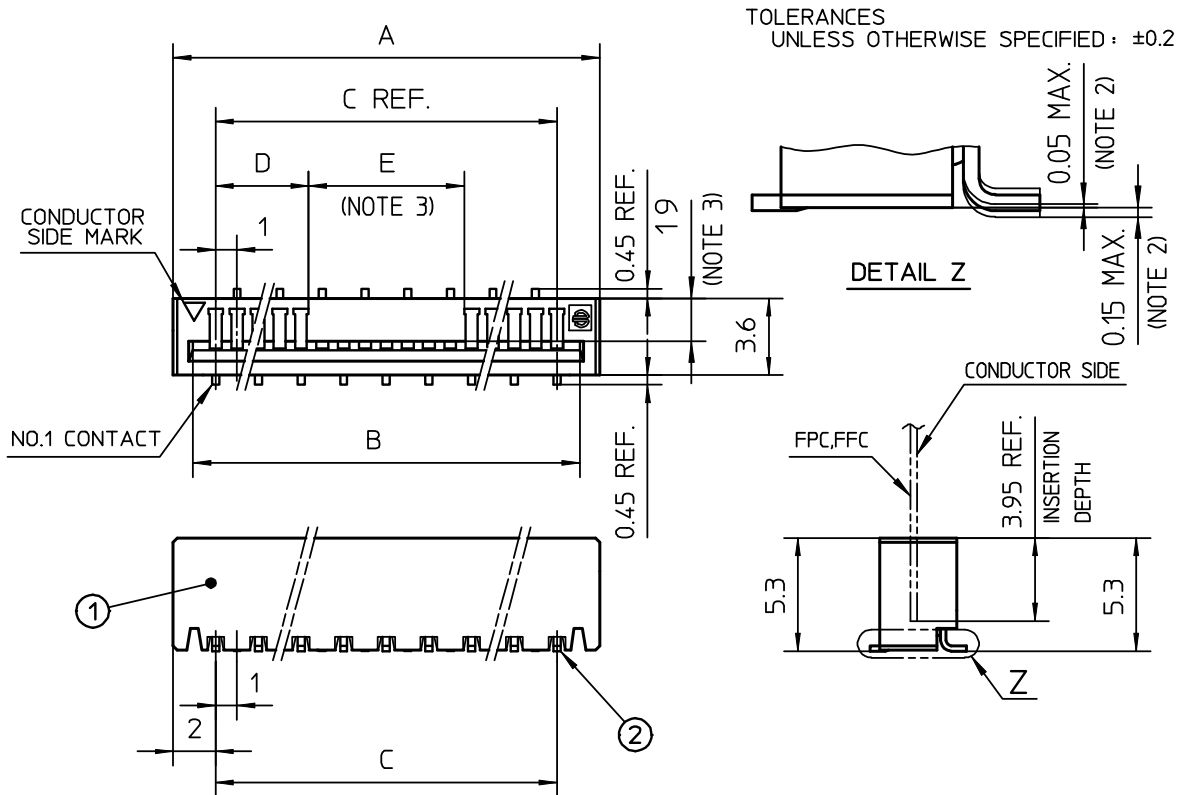

PT. NO.	PARTS NAME	MATERIAL	Q'TY	NOTE
1	HOUSING	PA6T RESIN GLASS REINFORCED (UL94V-0)	1	COLOR :BLACK
2	CONTACT	PHOSPHOR BRONZE	n	PLATING : TIN ALLOY

n : NO. OF CONTACTS

RECOMMENDED PC BOARD LAYOUT
(COMPONENT SIDE)

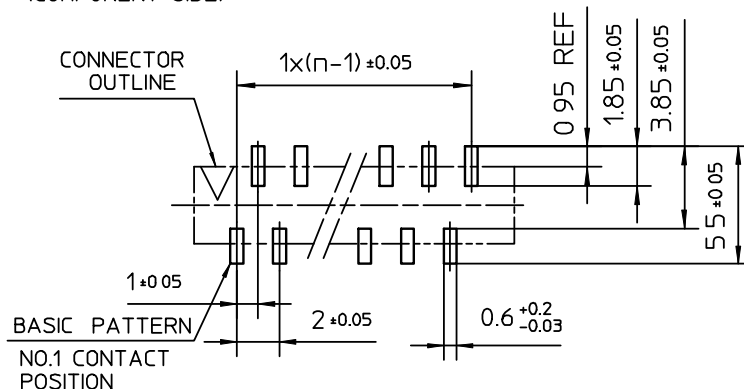

NOTES

1. THIS PRODUCT IS THE CONNECTOR DSGINED TO TERMINATE FPC/FFC AND COPEs WITH AUTOMATIC MOUNTING (SMT).
2. FLATNESS OF CONTACT TERMINAL MUST BE WITHIN TOLERANCE IN Z PORTION DETAILED DRAWING.
3. THIS DIMENSION IS SPACE FOR THE NOZZLE OF MOUNTER.

				SCALE	∞	1mm SPACING SURFACE MOUNT FPC/FFC CONNECTOR	
				DIM. IN	mm	CAT NO.	
				DESIGNED		HFW__S-2ST__	
				DRAWN		DRAWING NO	REV
				CHECKED		JSA 93585	
				APPROVED			
REV.	DATE	DESCRIPTION	DWN.	APPD.	DATE		

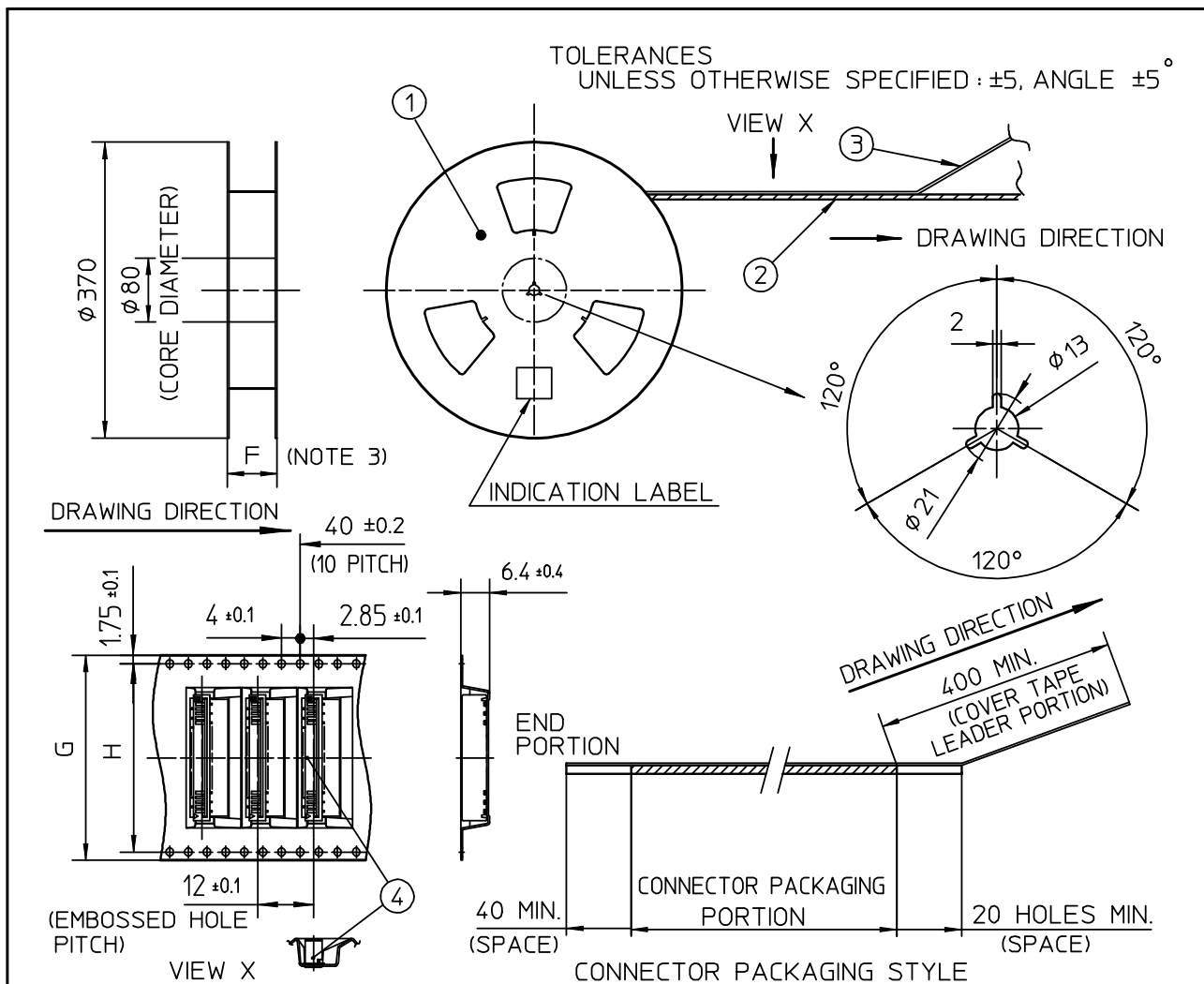

PT. NO.	PARTS NAME	CAT. NO.	MATERIAL	Q'TY	NOTE
1	REEL	_____	CARDBOARD	1	COLOR : GRAY
2	PLASTIC (EMBOSSSED) TAPE	_____	PET	_____	COLOR : TRANSPARENCY
3	COVER	_____	POLYESTER	_____	COLOR : TRANSPARENCY
4	CONNECTOR	HFWS-2ST__	SEE ATTACHED DWG.	1000	_____

NOTES

- THIS IS PLASTIC TAPE PACKAGED CONNECTOR USED FOR FPC/FFC AND COPES WITH AUTOMATIC MOUNTING (SMT).
- SEE JIS C 0806 (PACKING OF ELECTRONIC COMPONENTS ON CONTINUOUS TAPES (SURFACE MOUNTING DEVICES)) FOR SHAPE AND DIMENSIONS OF PLASTIC (EMBOSSSED) TAPE AND REEL.
- F DIMENSION IS PORTION OF THE CORE.

				SCALE	×	PLASTIC TAPE PACKAGED 1mm SPACING SMT CONNECTOR	
				DIM. IN	mm	CAT NO.	
				DESIGNED		HFWS-2STE1	
				DRAWN		DRAWING NO	REV
				CHECKED		JSA 93583	
				APPROVED			
REV.	DATE	DESCRIPTION	DWN.	APPD.	DATE		

RECOMMENDED CABLE (FFC)

n : NO. OF CONDUCTOR

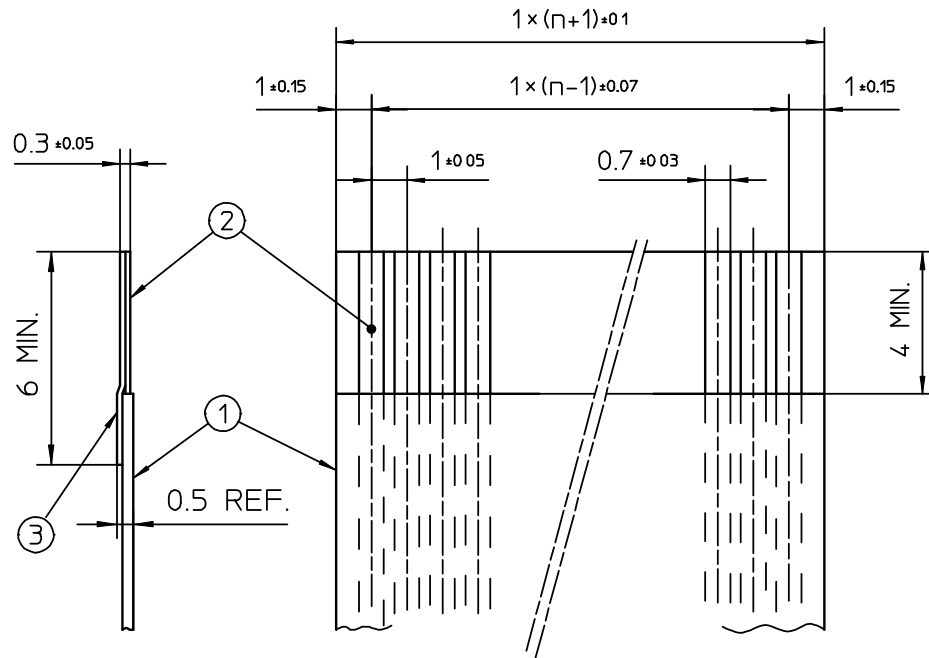

PT. NO.	DESCRIPTION	MATERIAL	NOTE
1	INSULATOR	FLAME RESISTING POLYESTER OR EQUIVALENT	_____
2	CONDUCTOR	COPPER FOIL	PLATING : TIN OR SOLDER 1μm MIN.
3	SUPPORTING TAPE	FLAME RESISTING POLYESTER OR EQUIVALENT	_____

NOTES

1. NO BURR AT EACH PORTION.
2. NO PEELING IN COMMON USE.

				SCALE	∞	RECOMMENDED CABLE	
				DIM. IN	mm	CAT NO.	
				DESIGNED		HFW__S-2ST__	
				DRAWN		DRAWING NO	REV
				CHECKED		JSA 93588	
				APPROVED		 DF-136 REV.B	
REV.	DATE	DESCRIPTION	DWN. APPD.	DATE			

RECOMMENDED CABLE (FPC)

n : NO. OF CONDUCTORS

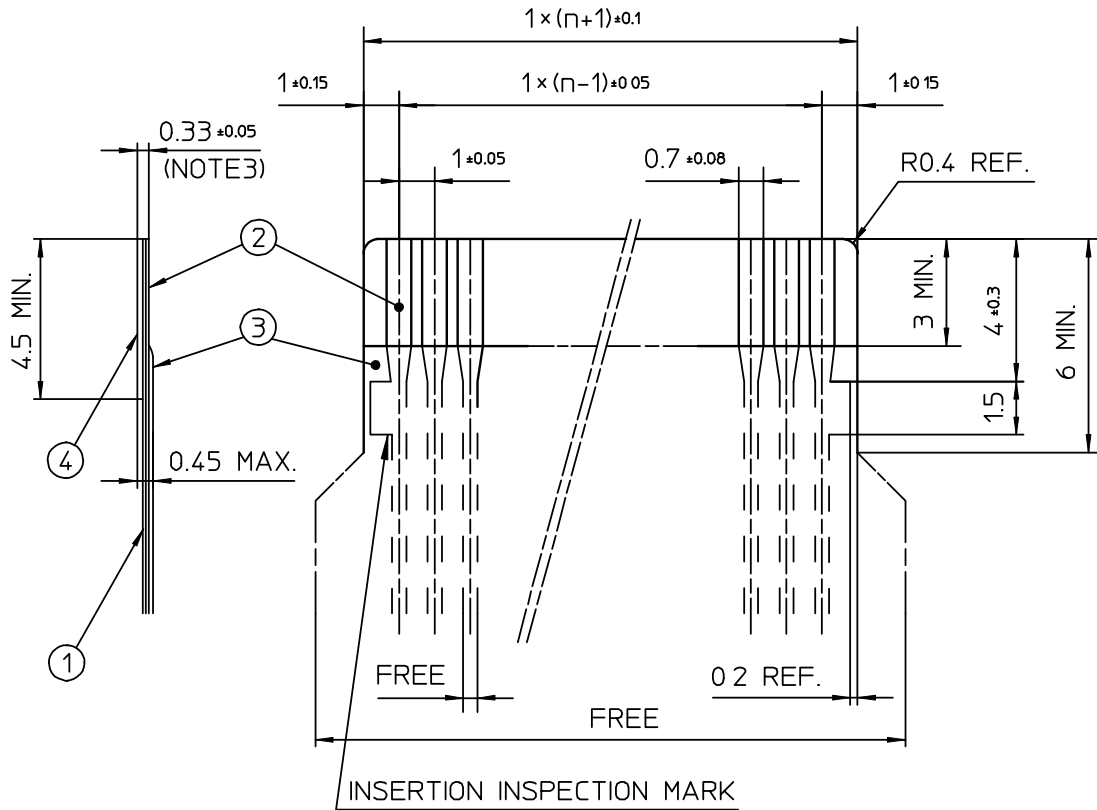

PT. NO.	DISCRIPTION	MATERIAL	THICKNESS (μm)
1	BASE FILM	POLYIMIDE OR POLYESTER OR EQUIVALENT	25
2	CONDUCTOR	COPPER FOIL(PLATING : SOLDER 1μm MIN.)	35
3	OVERLAY	POLYIMIDE OR POLYESTER OR EQUIVALENT	—
4	SUPPORTING TAPE	POLYESTER OR POLYIMIDE OR EQUIVALENT	188

NOTES

- 1 NO BURR AT EACH PORTION
2. NO PEELING IN COMMON USE.
3. TOTAL THICKNESS LIMIT OF EACH MATERIAL (INCLUDING ADHESIVE AGENT) IS SPECIFIED.

				SCALE	∞	RECOMMENDED CABLE	
				DIM. IN	mm	CAT NO.	
				DESIGNED		HFW__S-2ST__	
				DRAWN		DRAWING NO	REV
				CHECKED		JSA 93587	
				APPROVED		 DF-136 REV.B	
REV.	DATE	DESCRIPTION	DWN. APPD.	DATE			