

PRODUCT NO.
92194

REVISIONS				
REV	DESCRIPTION	ECN	BY	DATE
A	RELEASED	U30022	N.T	1/19/05
B	REVISED	U30062	N.T	5/2/05
C	REVISED	J40349	M.K	1/23/05
D	REVISED	M69558	M.K	1/29/06
E	REVISED	N90078	M.K	1/22/09
F	REVISED	104-0908	M.H	10/16/04
G	REVISED	105-0387	M.H	10/17/05

PRODUCT NO. #92194-XXXXX	STAND OFF DIM "M"(mm)	UPPER DECK			LOWER DECK			DIM "P" (mm)	HDR COLOR	SHEET NO.	MOUNTING STYLE TO PCB & DIRECTION OF PUSH ROD
		(MECH+HDR) 92111-XXXXX	(MECH) 92192-XXXX	(HDR) 92140-XXX	(MECH+HDR) 92193-XXXXX	(MECH) 92192-XXXX	(HDR) 92140-XXX				
000CA	0	000CA	00CA	005	100CA	10CA	000	2.8	BLACK	NO.2	
000CALF	0	000CALF	00CA	005LF	100CALF	10CA	000LF	2.8	BLACK		
020CA	2	020CA	00CA	045	120CA	12CA	040	2.5	BLACK	NO.3	
020CALF	2	020CALF	00CA	045LF	120CALF	12CA	040LF	2.5	BLACK		
100CA	0	100CA	10CA	005	000CA	00CA	000	2.8	BLACK	NO.4	
100CALF	0	100CALF	10CA	005LF	000CALF	00CA	000LF	2.8	BLACK		
120CA	2	120CA	10CA	045	020CA	02CA	040	2.5	BLACK	NO.5	
120CALF	2	120CALF	10CA	045LF	020CALF	02CA	040LF	2.5	BLACK		
200CA	0	000CA	00CA	005	000CA	00CA	000	2.8	BLACK	NO.6	
200CALF	0	000CALF	00CA	005LF	000CALF	00CA	000LF	2.8	BLACK		
200FA	0	000FA	00FA	005	000FA	00FA	000	2.8	BLACK	NO.7	
200FALF	0	000FALF	00FA	005LF	000FALF	00FA	000LF	2.8	BLACK		
220CA	2	020CA	00CA	045	020CA	02CA	040	2.5	BLACK	NO.8	
220CALF	2	020CALF	00CA	045LF	020CALF	02CA	040LF	2.5	BLACK		
300CA	0	100CA	10CA	005	100CA	10CA	000	2.8	BLACK	NO.9	
300CALF	0	100CALF	10CA	005LF	100CALF	10CA	000LF	2.8	BLACK		
320CA	2	120CA	10CA	045	120CA	12CA	040	2.5	BLACK	NO.10	
320CALF	2	120CALF	10CA	045LF	120CALF	12CA	040LF	2.5	BLACK		
320FA	2	120FA	10FA	045	120FA	12FA	040	2.5	BLACK	NO.11	
320FALF	2	120FALF	10FA	045LF	120FALF	12FA	040LF	2.5	BLACK		
500CA	0	600CA	00CA	505	500CA	10CA	500	2.8	NATURAL	NO.12	
500CALF	0	600CALF	00CA	505LF	500CALF	10CA	500LF	2.8	NATURAL		
500FA	0	600FA	00FA	505	500FA	10FA	500	2.8	NATURAL	NO.13	
500FALF	0	600FALF	00FA	505LF	500FALF	10FA	500LF	2.8	NATURAL		
520CA	2	620CA	00CA	545	520CA	12CA	540	2.5	NATURAL	NO.14	
520CALF	2	620CALF	00CA	545LF	520CALF	12CA	540LF	2.5	NATURAL		
600CA	0	500CA	10CA	505	600CA	00CA	500	2.8	NATURAL	NO.15	
600CALF	0	500CALF	10CA	505LF	600CALF	00CA	500LF	2.8	NATURAL		
620CA	2	520CA	10CA	545	620CA	02CA	540	2.5	NATURAL	NO.16	
620CALF	2	520CALF	10CA	545LF	620CALF	02CA	540LF	2.5	NATURAL		
700CA	0	500CA	10CA	505	500CA	10CA	500	2.8	NATURAL	NO.17	
700CALF	0	500CALF	10CA	505LF	500CALF	10CA	500LF	2.8	NATURAL		
720CA	2	520CA	10CA	545	520CA	12CA	540	2.5	NATURAL	NO.18	
720CALF	2	520CALF	10CA	545LF	520CALF	12CA	540LF	2.5	NATURAL		
800CA	0	600CA	00CA	505	600CA	00CA	500	2.8	NATURAL	NO.19	
800CALF	0	600CALF	00CA	505LF	600CALF	00CA	500LF	2.8	NATURAL		
820CA	2	620CA	00CA	545	620CA	02CA	540	2.5	NATURAL	NO.20	
820CALF	2	620CALF	00CA	545LF	620CALF	02CA	540LF	2.5	NATURAL		

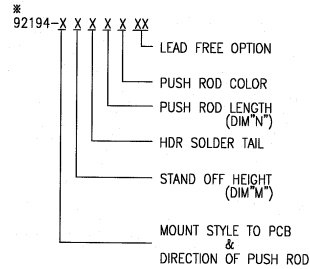

- NONE : NO
 LF : YES (SEE NOTE1)
 A : BLACK
 C : 13mm
 F : 21mm
 R : R/A
- 0 : 0mm(NONE)
 2 : 2mm
- 0 : TOP MOUNT & RIGHT-LEFT PUSH ROD
 1 : TOP MOUNT & LEFT-RIGHT PUSH ROD
 2 : TOP MOUNT & RIGHT-RIGHT PUSH ROD
 3 : TOP MOUNT & LEFT-LEFT PUSH ROD
 5 : BOTTOM MOUNT & RIGHT-LEFT PUSH ROD
 6 : BOTTOM MOUNT & LEFT-RIGHT PUSH ROD
 7 : BOTTOM MOUNT & RIGHT-RIGHT PUSH ROD
 8 : BOTTOM MOUNT & LEFT-LEFT PUSH ROD

NOTE
 1. THIS PRODUCT MEETS EUROPEAN UNION DIRECTIVES AND OTHER COUNTRY REGULATIONS AS DESCRIBED IN CS-22-008.

SHEET INDEX	ISSUE SH NO.	G	C	C	D	D	D	D	C	D	C										
TOLERANCES UNLESS OTHERWISE SPECIFIED		MAY		---		---		---		---		---		---		---		---		---	
LINEAR		FINISH		---		---		---		---		---		---		---		---		---	
ANGLES		---		---		---		---		---		---		---		---		---		---	

FCI

TITLE: 6BP DOUBLE EJECTOR HEADER ASSY FOR TYPE 1 / B / III

PRODUCT FAMILY: Header PCMCIA

SCALE: SIZE [DWG. NO. 92194] REV SHEET C 1 of 9

PART NO.		
92194-000CA	92194-000CALF	
92194-020CA	92194-020CALF	

REVISIONS				
REV	DESCRIPTION	ECN	BY	DATE
A	RELEASED	J30022	N.T	1/19/93
B	REVISED	J40349	M.K	1/23/95
C	REVISED	J95-0387	M.Hg	1/17/95

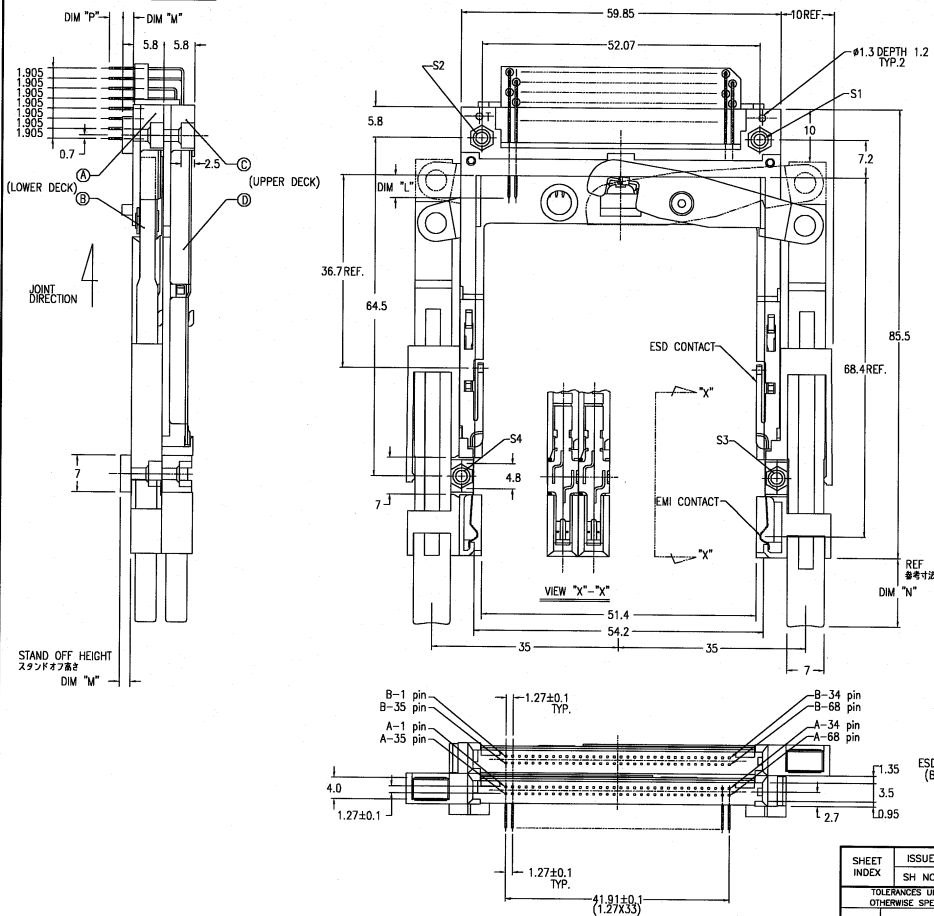

- NOTE
- EJECT FORCE 3.5kg MAX.
 - ASSY PROCESS
 - TO MOUNT PART ①, ② ON PWB WITH SCREW (S1,S2) AND SOLDER.
 - TO JOINT PART ③, ④ INTO PART ⑤, ⑥ THEN FIX PART ⑦, ⑧ WITH 2 SCREWS (S3,S4).
 - EJECT TRAVEL 8.0mm

- ③ MATERIAL
- PART ①, ② (HEADER ASSY)
 - PLASTIC : HOUSING : LCP UL94V-0 BLACK
 - LOCATOR : G.F.6/6 NYLON UL94V-0 BLACK
 - PIN : PHOSPHOR BRONZE
 - PART ③, ④ (EJECT MECHANISM ASSY)
 - PLASTIC : GUIDE : POLYETHYLENE TEREPHTHALATE UL94V-0 BLACK
 - PUSH ROD : POLYETHYLENE TEREPHTHALATE UL94V-0 BLACK
 - PLATE : STAINLESS
 - EMI CONTACT : PHOSPHOR BRONZE

⑤ -1 FINISH (PIN)	UNDER PLATING : 0.5 μm MIN. Ni
	CONTACT AREA : 0.1 μm MIN. GOLD OVER 0.5 μm MIN. Pd-Ni
	SOLDER TAIL : 2.5 μm MIN. Sn-Pb.
⑤ -2 FINISH (PIN) (FOR *****LF)	UNDER PLATING : 0.5 μm MIN. Ni
	CONTACT AREA : 0.1 μm MIN. GOLD OVER 0.5 μm MIN. Pd-Ni
	SOLDER TAIL : 2.5 μm MIN. Sn.

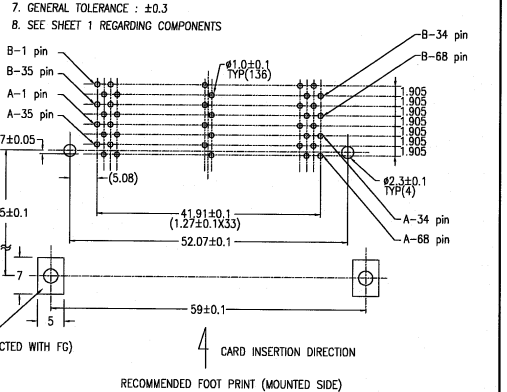

SD NOT SCALE. PRINT THIS INFORMATION IS CONFIDENTIAL AND IS DISCLOSED TO YOU ON CONDITION THAT NO FURTHER DISCLOSURE IS MADE BY YOU TO OTHER THAN FCI PERSONNEL WITHOUT WRITTEN AUTHORIZATION FROM FCI JAPAN K.K.

SHEET INDEX	ISSUE SH. NO.	DATE	DR. <i>M. Hasegawa</i>	REV. 6/17/95	CUSTOMER COPY	FCI	DBP DOUBLE EJECTOR HEADER ASSY FOR TYPE I / II / III	CODE 2F
TOLERANCES UNLESS OTHERWISE SPECIFIED		SEE NOTE ①	CHK. <i>M. Hasegawa</i>	6/17/95	THIRD ANGLE PROJ.	PRODUCT FAMILY	Scale Header PCMCIA	REV SHEET
LINEAR		SEE NOTE ②	APPD. <i>M. Hasegawa</i>	6/21/95	UNIT	SCALE SIZE	DWG. NO. 92194	2 of 2
ANGLES								

PRODUCT NO.		
92194-100CA	92194-100CALF	
92194-120CA	92194-120CALF	

REVISIONS				
REV	DESCRIPTION	ECN	BY	DATE
A	RELEASED	J30022	N.T.	1/19/93
B	REVISED	J40349	M.K.	1/24/96
C	REVISED	J05-0367	M.H.	6/17/98

- NOTE
- EJECT FORCE 3.5kg MAX.
 - ASSY PROCESS
 - TO MOUNT PART ④, ⑤ ON PWB WITH SCREW (S1,S2) AND SOLDER.
 - TO JOINT PART ③, ④ INTO PART ② THEN FIX PART ③, ④ WITH 2 SCREWS (S3,S4).
 - EJECT TRAVEL 8.0mm

- ④ MATERIAL
- PART ④, ⑤ (HEADER ASSY)
 - PLASTIC : HOUSING : LCP UL94V-0 BLACK
 - LOCATOR : G.F.6/6 NYLON UL94V-0 BLACK
 - PIN : PHOSPHOR BRONZE
 - PART ③, ④ (EJECT MECHANISM ASSY)
 - PLASTIC : GUIDE : POLYETHYLETHERIMID UL94V-0 BLACK
 - PUSH ROD : POLYETHYLETHERIMID UL94V-0 BLACK
 - PLATE : STAINLESS
 - EMI CONTACT : PHOSPHOR BRONZE

- ⑤ -1 FINISH (PIN)
- UNDER PLATING : 0.5 μm MIN. Ni
 - CONTACT AREA : 0.1 μm MIN. GOLD OVER 0.5 m MIN. Pd-Ni.
 - SOLDER TAIL : 2.5 μm MIN. Sn-Pb.
- ⑤ -2 FINISH (PIN) (FOR -*****F)
- UNDER PLATING : 0.5 μm MIN. Ni
 - CONTACT AREA : 0.1 μm MIN. GOLD OVER 0.5 μm MIN. Pd-Ni.
 - SOLDER TAIL : 2.5 μm MIN. Sn.

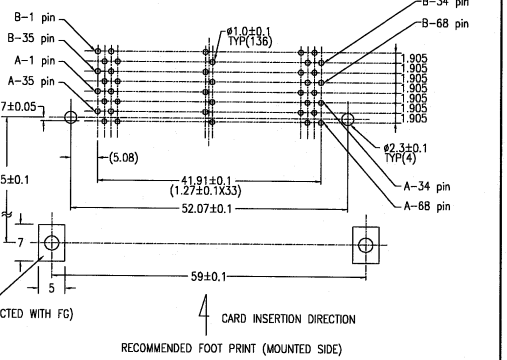

SHEET INDEX		ISSUE		DATE		CUSTOMER COPY		TITLE	
INDEX	SH. NO.	SH. NO.	SH. NO.	DATE	DATE	DATE	DATE	DATE	DATE
TOLERANCES UNLESS OTHERWISE SPECIFIED		MAY		DR. M. Hasegawa		RAY		TITLE 68P DOUBLE EJECTOR HEADER ASSY FOR TYPE I / II / III	
LINEAR		FINISH		CHK. M. Hasegawa		ENG. 6/17/95		PRODUCT FAMILY SANK Header PCMCIA	
ANGLES		APPROV. M. Hasegawa		APPROV. M. Hasegawa		UNIT MM		SCALE SIZE DWG. NO. 2/1 C 92194	
								REV SHEET C 30f	

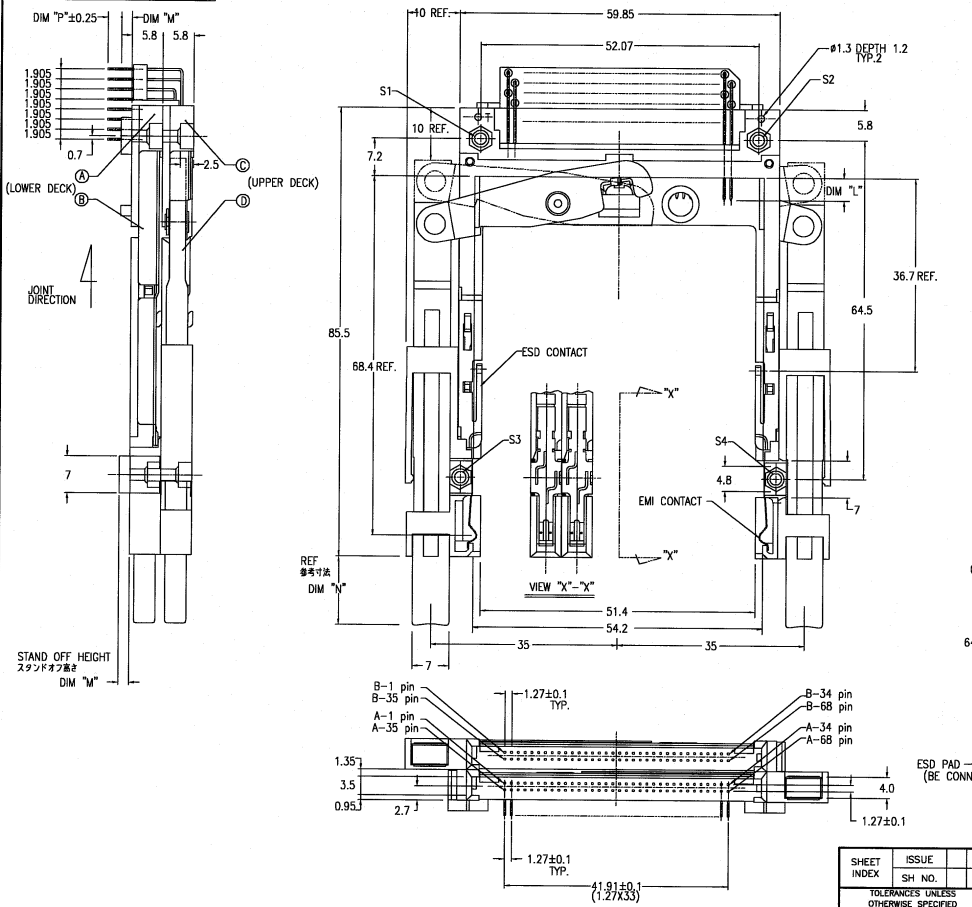

5F-003A Rev F
 52. NOT SCALE. PRINT THIS INFORMATION IS CONFIDENTIAL AND IS DISCLOSED TO YOU ON CONDITION THAT NO FURTHER DISCLOSURE IS MADE BY YOU TO OTHER THAN FCI PERSONNEL WITHOUT WRITTEN AUTHORIZATION FROM FCI JAPAN K.K.

PART NO.	
92194-200CA	92194-200CALF
92194-200FA	92194-200FALF
92194-220CA	92194-220CALF

REVISIONS				
REV	DESCRIPTION	ECN	BY	DATE
A	RELEASED	J30022	N.T.	19/10/13
B	REVISED	J40349	M.KB	23/10/16
C	REVISED	v04-0000	M.KB	18/10/14
D	REVISED	v05-0307	M.HB	11/10/15

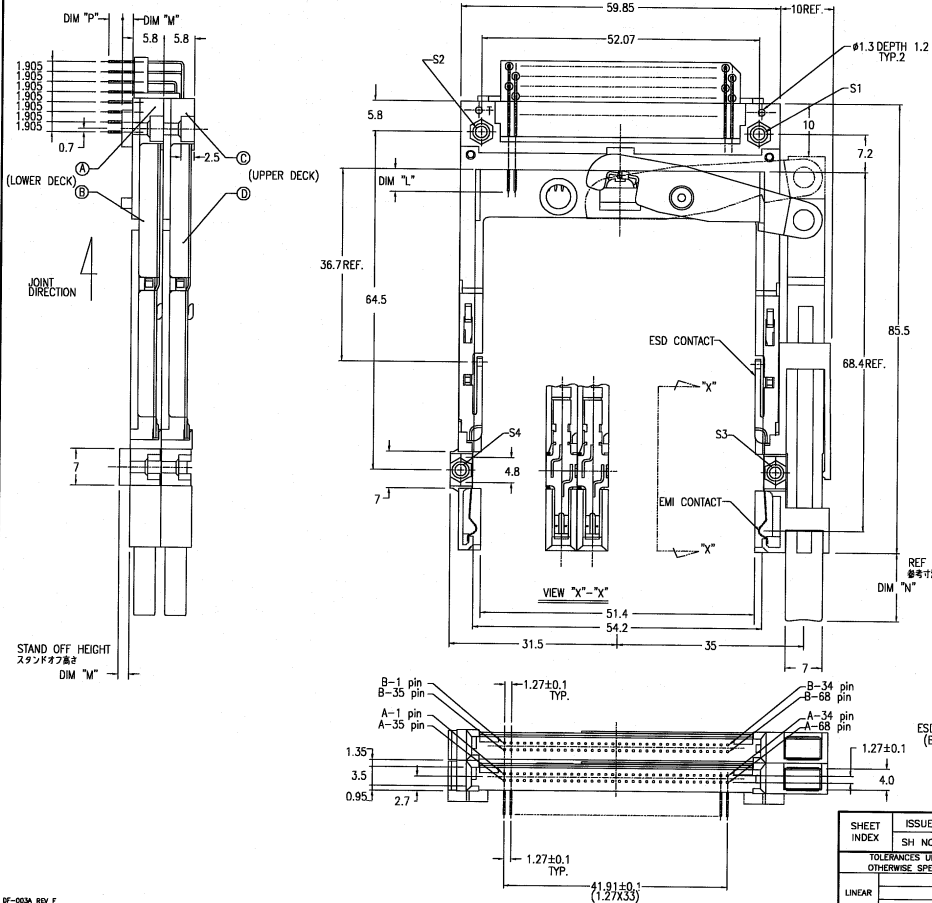

- NOTE
- EJECT FORCE 3.5kg MAX.
 - ASSY PROCESS
 - TO MOUNT PART ①, ② ON PWB WITH SCREW (S1,S2) AND SOLDER.
 - TO JOINT PART ③, ④ INTO PART ⑤ THEN FIX PART ③, ④ WITH 2 SCREWS (S3,S4).
 - EJECT TRAVEL 8.0mm

- ③ MATERIAL
- PART ①, ② (HEADER ASSY)
 - PLASTIC : HOUSING : LCP UL94V-0 BLACK
 - LOCATOR : G.F.6/6 NYLON UL94V-0 BLACK
 - PIN : PHOSPHOR BRONZE
 - PART ③, ④ (EJECT MECHANISM ASSY)
 - PLASTIC : GUIDE : POLYETHYLETHERIMIDE UL94V-0 BLACK
 - PUSH ROD : POLYETHYLETHERIMIDE UL94V-0 BLACK
 - PLATE : STAINLESS
 - EMI CONTACT : PHOSPHOR BRONZE
- ⑤ -1 FINISH (PIN)
- UNDER PLATING : 0.5 μm MIN. Ni
 - CONTACT AREA : 0.1 μm MIN. GOLD OVER 0.5 μm MIN. Pd-Ni
 - SOLDER TAIL : 2.5 μm MIN. Sn-Pb.
- ⑤ -2 FINISH (PIN) (FOR -*****LF)
- UNDER PLATING : 0.5 μm MIN. Ni
 - CONTACT AREA : 0.1 μm MIN. GOLD OVER 0.5 μm MIN. Pd-Ni
 - SOLDER TAIL : 2.5 μm MIN. Sn.

4.25±0.1	3.5±0.1	5.0±0.1
OTHERS	36.67	33.768

7. GENERAL TOLERANCE : ±0.3

8. SEE SHEET 1 REGARDING COMPONENTS.

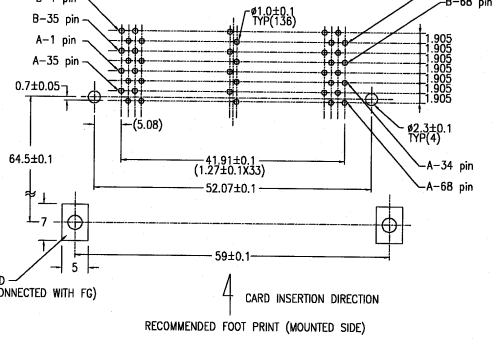

DO NOT SCALE PRINT THIS INFORMATION IS CONFIDENTIAL AND IS DISCLOSED TO YOU ON CONDITION THAT NO FURTHER DISCLOSURE IS MADE BY YOU TO OTHER THAN FCI PERSONNEL WITHOUT WRITTEN AUTHORIZATION FROM FCI JAPAN K.K.

SHEET INDEX	ISSUE SH. NO.	MAY	DR. M. Hasegawa	DATE	CUSTOMER COPY	TITLE	PRODUCT FAMILY	SCALE	SIZE	DWG. NO.	REV	SHEET
		SEE NOTE ④	CHK. M. Hasegawa	6/11/15		8BP DOUBLE EJECTOR HEADER ASSY FOR TYPE I / II / III	Header PCMCIA	2/1	C	92194	D	4of
		SEE NOTE ⑤	APP. M. Hasegawa	6/11/15								

PRODUCT NO.	
92194-300CA	92194-300CALF
92194-320CA	92194-320CALF
92194-320FA	92194-320FALF

REVISIONS			
REV	DESCRIPTION	ECN	BY DATE
A	RELEASED	J30022	N.T/19/03
B	REVISED	J40349	M.K/23/06
C	REVISED	N90076	M.K/22/09
D	REVISED	85-087	M.H/17/05

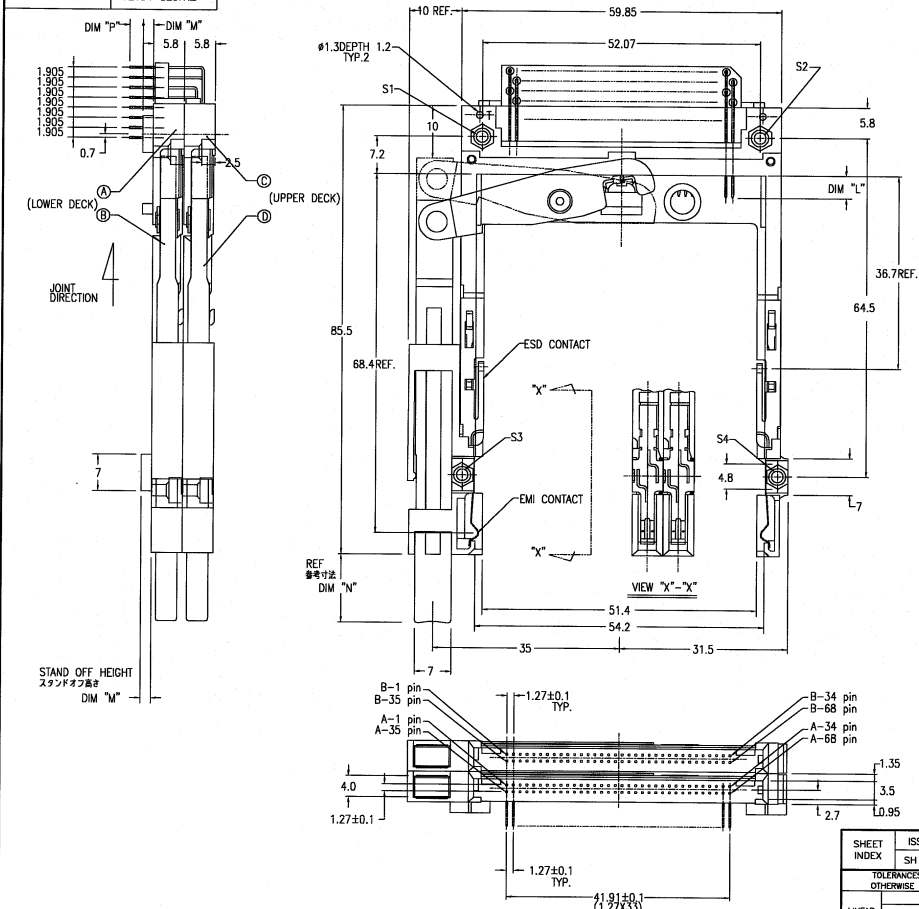

- NOTE
- EJECT FORCE 3.5kg MAX.
 - ASSY PROCESS
 - TO MOUNT PART ①, ② ON PWB WITH SCREW (S1,S2) AND SOLDER.
 - TO JOINT PART ③, ④ INTO PART ⑤ THEN FIX PART ⑥, ⑦ WITH 2 SCREWS (S3,S4).
 - EJECT TRAVEL 8.0mm
 - MATERIAL
 - PART ①, ② (HEADER ASSY)
 - PLASTIC : HOUSING : LCP UL94V-0 BLACK
 - LOCATOR : G.F.6/6 NYLON UL94V-0 BLACK
 - PIN : PHOSPHOR BRONZE
 - PART ③, ④ (EJECT MECHANISM ASSY)
 - PLASTIC : GUIDE : POLYIMIDAMIDE UL94V-0 BLACK
 - PUSH ROD : POLYIMIDAMIDE UL94V-0 BLACK
 - PLATE : STAINLESS
 - EM CONTACT : PHOSPHOR BRONZE
 - FINISH (PIN)
 - FINISH (PIN)
 - UNDER PLATING : 0.5 μm MIN. Ni
 - CONTACT AREA : 0.1 μm MIN. GOLD OVER 0.5 μm MIN. Pd-Ni
 - SOLDER TAIL : 2.5 μm MIN. Sn-Pb.
 - FINISH (PIN) (FOR -*****LF)
 - UNDER PLATING : 0.5 μm MIN. Ni
 - CONTACT AREA : 0.1 μm MIN. GOLD OVER 0.5 μm MIN. Pd-Ni
 - SOLDER TAIL : 2.5 μm MIN. Sn.

4.25±0.1	3.5±0.1	5.0±0.1
OTHERS	35.67	39.78

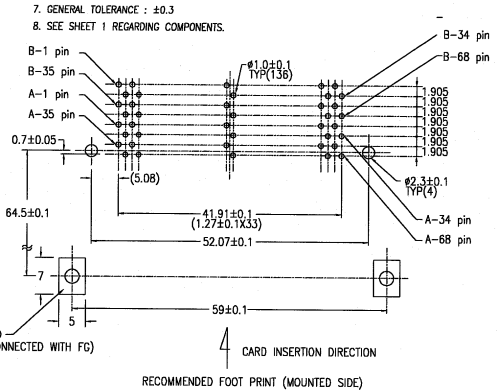

DO NOT SCALE PRINT THIS INFORMATION IS CONFIDENTIAL AND IS DISCLOSED TO YOU ON CONDITION THAT NO FURTHER DISCLOSURE IS MADE BY YOU TO OTHER THAN FCI PERSONNEL WITHOUT WRITTEN AUTHORIZATION FROM FCI JAPAN K.K.

SHEET INDEX	ISSUE SH. NO.	DATE	DR	ENGR	CHECK	APPD	CUSTOMER COPY	UNIT	SCALE	SIZE	DWG. NO.	REV	SHEET
			M. Hasegawa	6/17/05				MM	2/1	C	92194	D	5 of



FCI
TITLE: 68P DOUBLE EJECTOR HEADER ASSY FOR TYPE 1/II/III
PRODUCT FAMILY: Stamp Header PCMCIA
SCALE: 2/1
SIZE: C
DWG. NO.: 92194
REV: D
SHEET: 5 of

PART NO.	
92194-500CA	92194-500CALF
92194-500FA	92194-500FALF
92194-520CA	92194-520CALF

REVISIONS				
REV	DESCRIPTION	ECN	BY	DATE
A	RELEASED	J30022	N.T	1/19/03
B	REVISED	J40349	M.K	1/23/05
C	REVISED	M60958	M.K	7/29/06
D	REVISED	065-0367	M.H	6/17/06

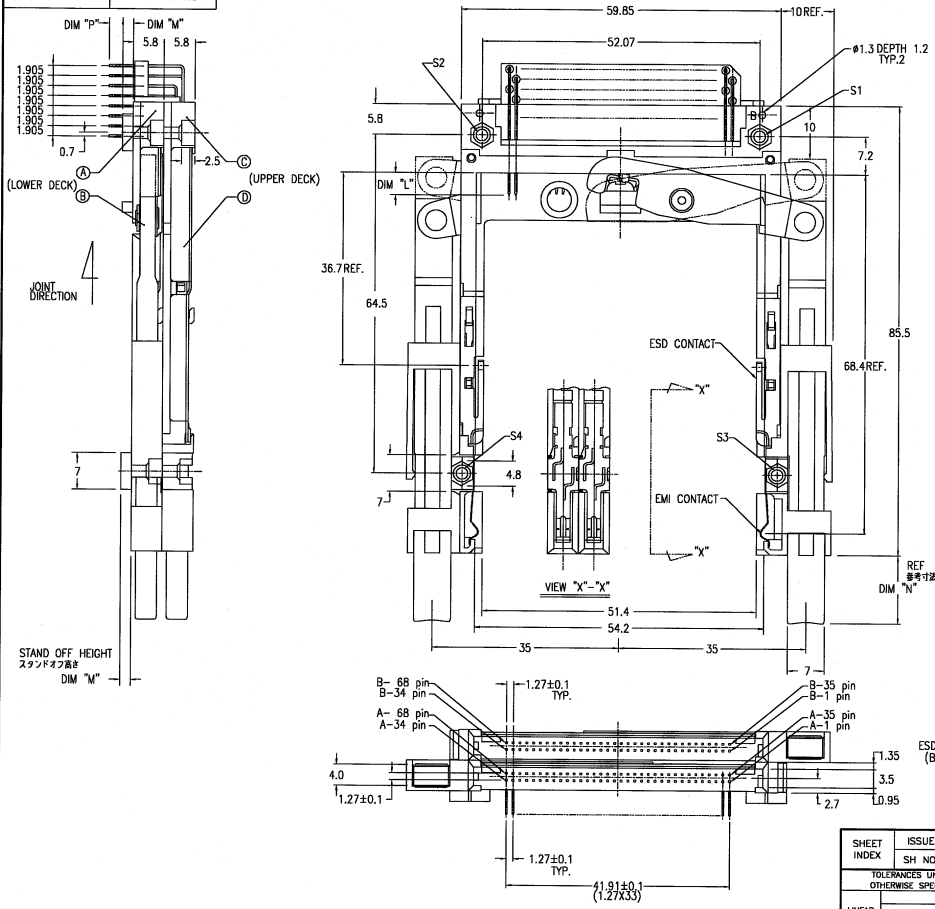

NOTE

- EJECT FORCE 3.5kg MAX.
- ASSY PROCESS
 - TO MOUNT PART ①, ② ON PWB WITH SCREW (S1,S2) AND SOLDER.
 - TO JOINT PART ③, ④ INTO PART ⑤ THEN FIX PART ⑥, ⑦ WITH 2 SCREWS (S3,S4).
- EJECT TRAVEL 8.0mm
- MATERIAL
 - PART ①, ② (HEADER ASSY)
 - PLASTIC : HOUSING : LCP UL94V-0 NATURAL
 - LOCATOR : G.F.6/NYLON UL94V-0 BLACK
 - PIN : PHOSPHOR BRONZE
 - PART ③, ④ (EJECT MECHANISM ASSY)
 - PLASTIC : GUIDE : POLYIMIDAMIDE UL94V-0 BLACK
 - PUSH ROD : POLYIMIDAMIDE UL94V-0 BLACK
 - PLATE : STAINLESS
 - EMI CONTACT : PHOSPHOR BRONZE

⑤ -1 FINISH (PIN)
 UNDER PLATING : 0.5 μm MIN. Ni
 CONTACT AREA : 0.1 μm MIN. GOLD OVER 0.5 μm MIN. Pd-Ni
 SOLDER TAIL : 2.5 μm MIN. Sn-Pb.

⑤ -2 FINISH (PIN) (FOR -*****LF)
 UNDER PLATING : 0.5 μm MIN. Ni
 CONTACT AREA : 0.1 μm MIN. GOLD OVER 0.5 μm MIN. Pd-Ni
 SOLDER TAIL : 2.5 μm MIN. Sn.

4.25±0.1	3.5±0.1	5.0±0.1
OTHERS	36.67	33.76

7. GENERAL TOLERANCE : ±0.3
 8. SEE SHEET 1 REGARDING COMPONENTS.

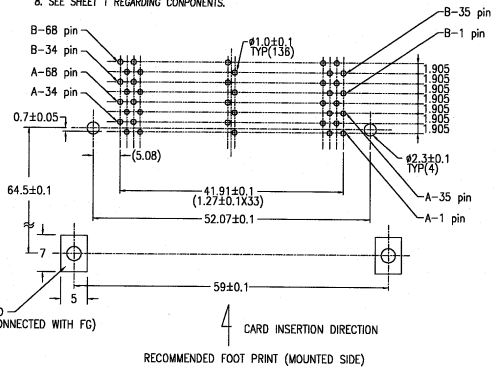

SHEET INDEX	ISSUE SH NO.	DATE	CUSTOMER COPY	TITLE	PRODUCT FAMILY	SCALE	SIZE	DWG. NO.	REV	SHEET
		0/17/06		68P DOUBLE EJECTOR HEADER ASSY FOR TYPE 1/II/III	Header PCMCIA	2/1	C	92194	D	6 of

3F-003A Rev F
 DO NOT SCALE. PRINT THIS INFORMATION IS CONFIDENTIAL AND IS DISCLOSED TO YOU ON CONDITION THAT NO FURTHER DISCLOSURE IS MADE BY YOU TO OTHER THAN FCI PERSONNEL WITHOUT WRITTEN AUTHORIZATION FROM FCI JAPAN K.K.

PART NO.	
92194-700CA	92194-700CALF
92194-720CA	92194-720CALF

REVISIONS				
REV	DESCRIPTION	ECN	BY	DATE
A	RELEASED	J30022	N.T	1/19/93
B	REVISED	J30062	N.T	2/2/93
C	REVISED	J40349	M.K	1/23/95
D	REVISED	085-0387	M.H	1/17/95

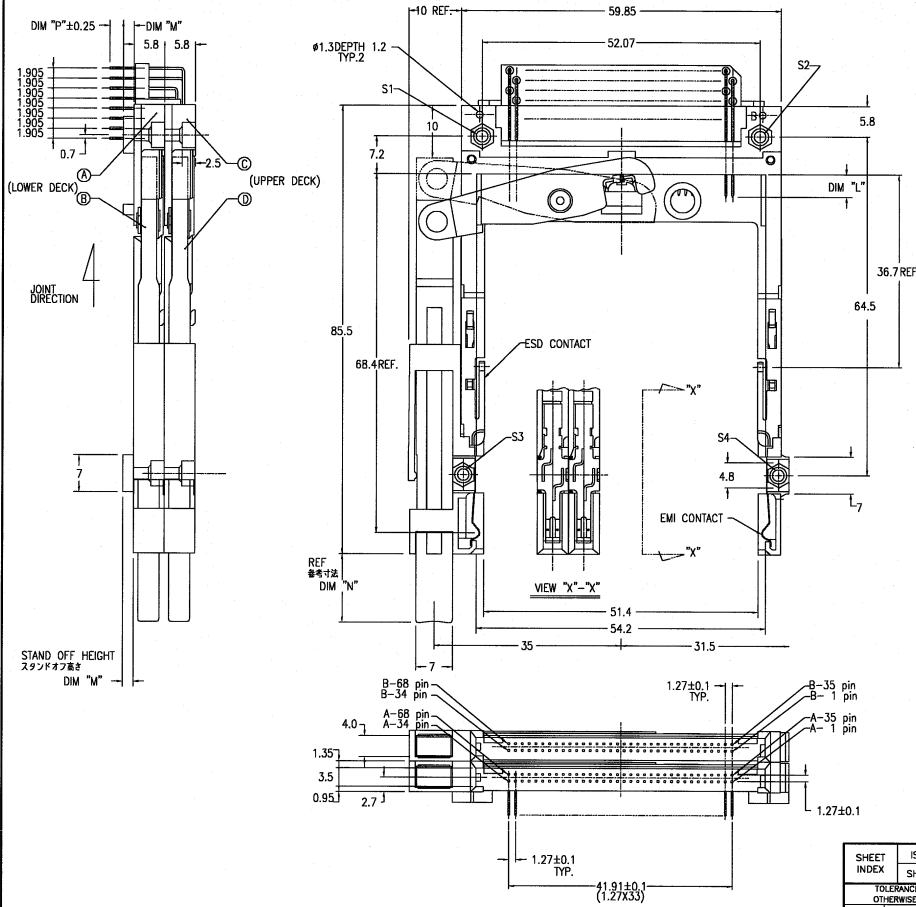

- NOTE
- EJECT FORCE 3.5kg MAX.
 - ASSY PROCESS
 - 2.1 TO MOUNT PART ④, ⑤ ON PWB WITH SCREW (S1,S2) AND SOLDER.
 - 2.2 TO JOINT PART ⑥, ⑦ INTO PART ④ THEN FIX PART ⑥, ⑦ WITH 2 SCREWS (S3,S4).
 - EJECT TRAVEL 8.0mm
 - MATERIAL

④ PART ④ (HEADER ASSY)
 PLASTIC : HOUSING : LCP UL94V-0 NATURAL
 LOCATOR : G.F.6/6 NYLON UL94V-0 BLACK
 PIN : PHOSPHOR BRONZE

⑤ PART ⑤ (EJECT MECHANISM ASSY)
 PLASTIC : GUIDE : POLYIMIDAMIDE UL94V-0 BLACK
 PUSH ROD : POLYIMIDAMIDE UL94V-0 BLACK
 PLATE : STAINLESS
 EMI CONTACT : PHOSPHOR BRONZE

⑥ -1 FINISH (PIN)
 UNDER PLATING : 0.5 μm MIN. Ni
 CONTACT AREA : 0.1 μm MIN. GOLD OVER 0.5 m MIN. Pd-Ni
 SOLDER TAIL : 2.5 μm MIN. Sn-Pb.

⑥ -2 FINISH (PIN) (FOR -*****F)
 UNDER PLATING : 0.5 μm MIN. Ni
 CONTACT AREA : 0.1 μm MIN. GOLD OVER 0.5 μm MIN. Pd-Ni
 SOLDER TAIL : 2.5 μm MIN. Sn.

6. DIM "L"

4.25±0.1	3.5±0.1	5.0±0.1
OTHERS	36.67	31.75

- GENERAL TOLERANCE : ±0.3
- SEE SHEET 1 REGARDING COMPONENTS

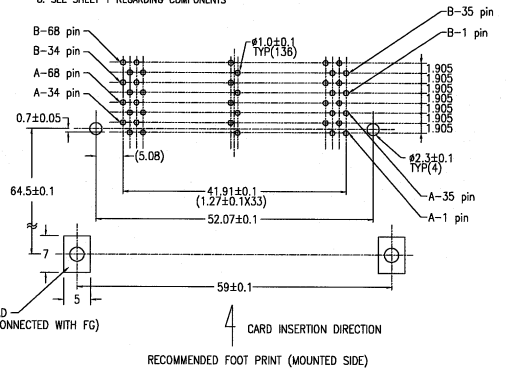

DF-003A REV 1
 DO NOT SCALE PRINT THIS INFORMATION IS CONFIDENTIAL AND IS DISCLOSED TO YOU ON CONDITION THAT NO FURTHER DISCLOSURE IS MADE BY YOU TO OTHER THAN FCI PERSONNEL WITHOUT WRITTEN AUTHORIZATION FROM FCI JAPAN K.K.

SHEET INDEX	ISSUE	SH. NO.	DATE	BY	CHKD.	APPD.	UNIT	SCALE	SIZE	DWG. NO.	REV	SHEET

TOLERANCES UNLESS OTHERWISE SPECIFIED

LINEAR FINISH SEE NOTE ④

ANGLES SEE NOTE ⑤

DR. *M. Hasegawa* 6/17/95

CHKD. *M. Hasegawa* 6/17/95

APPD. *M. Hasegawa* 6/22/95

CUSTOMER COPY

180 ANGLE PRO.

UNIT: mm

SCALE: 2/1

SIZE: C

DWG. NO.: 92194

REV: D

SHEET: 8 of 8

TITLE: 68B DOUBLE EJECTOR HEADER ASSY FOR TYPE 1 / II / III

PRODUCT FAMILY: SANF Header PCMCIA

PART NO.	
92194-800CA	92194-800CALF
92194-820CA	92194-820CALF

REVISIONS			
REV	DESCRIPTION	ECN	BY DATE
A	RELEASED		N.T/19/92
B	REVISED	140.349	M.K/23/95
C	REVISED	105-0367	M.H/17/95

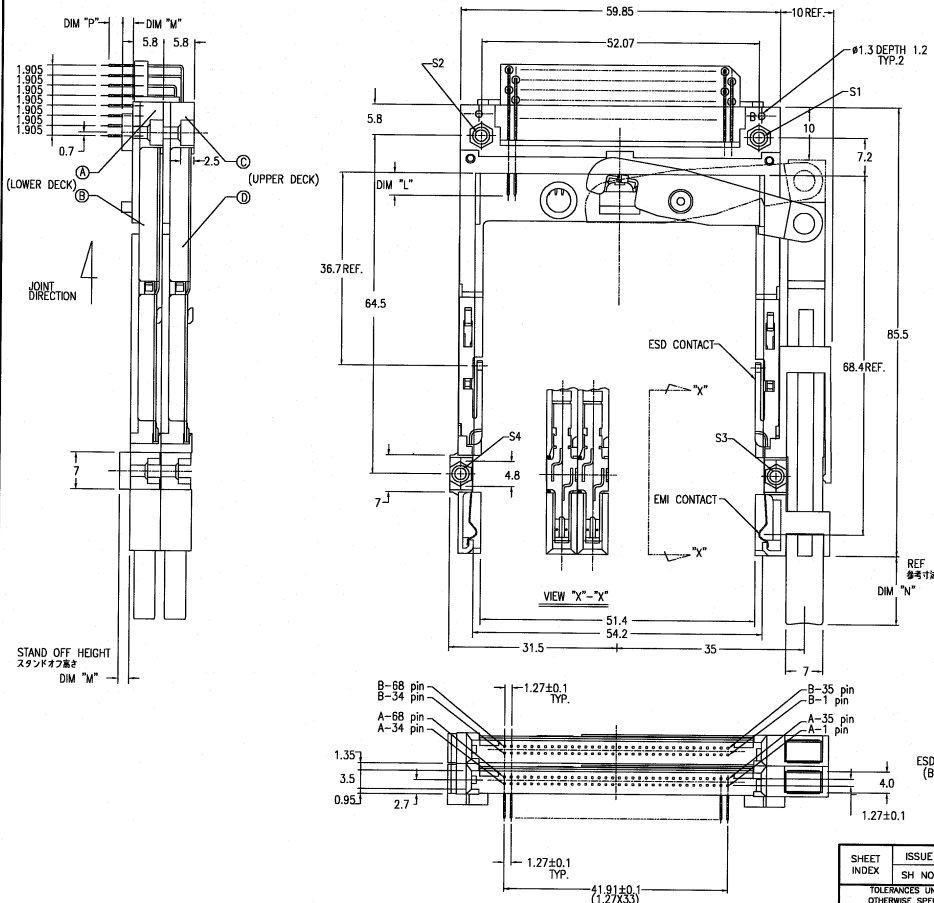

NOTE
 1. EJECT FORCE 3.5kg MAX.
 2. ASSY PROCESS
 2.1 TO MOUNT PART ①, ② ON PWB WITH SCREW (S1,S2) AND SOLDER.
 2.2 TO JOINT PART ③, ④ INTO PART ⑤, ⑥ THEN FIX PART ③, ④ WITH 2 SCREWS (S3,S4).
 3. EJECT TRAVEL 8.0mm
 ③ MATERIAL

4.1 PART ①, ② (HEADER ASSY)
 PLASTIC : HOUSING : LCP UL94V-0 NATURAL
 LOCATOR : G.F.6/6 NYLON UL94V-0 BLACK
 PIN : PHOSPHOR BRONZE
 4.2 PART ③, ④ (EJECT MECHANISM ASSY)
 PLASTIC : GUIDE : POLYETHYLENE TEREPHTHALATE UL94V-0 BLACK
 PUSH ROD : POLYETHYLENE TEREPHTHALATE UL94V-0 BLACK
 PLATE : STAINLESS
 EMI CONTACT : PHOSPHOR BRONZE

⑤ -1 FINISH (PIN)
 UNDER PLATING : 0.5 μm MIN. Ni
 CONTACT AREA : 0.1 μm MIN. GOLD OVER 0.5 μm MIN. Pd-Ni.
 SOLDER TAIL : 2.5 μm MIN. Sn-Pb.

⑥ -2 FINISH (PIN) (FOR -*****LF)
 UNDER PLATING : 0.5 μm MIN. Ni
 CONTACT AREA : 0.1 μm MIN. GOLD OVER 0.5 μm MIN. Pd-Ni.
 SOLDER TAIL : 2.5 μm MIN. Sn.

4.25±0.1	3.5±0.1	5.0±0.1
OTHERS	36.67	35.5/36

7. GENERAL TOLERANCE : ±0.3
 8. SEE SHEET 1 REGARDING COMPONENTS.

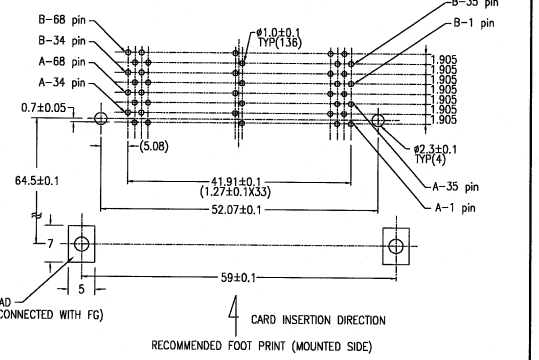

68-003A REV F
 DO NOT SCALE. PRINT THIS INFORMATION IS CONFIDENTIAL AND IS DISCLOSED TO YOU ON CONDITION THAT NO FURTHER DISCLOSURE IS MADE BY YOU TO OTHER THAN FCI PERSONNEL WITHOUT WRITTEN AUTHORIZATION FROM FCI JAPAN K.K.

SHEET INDEX	ISSUE SH NO.	MAY	DR. H. KAWAGUCHI	DATE	CUSTOMER COPY	TITLE	PRODUCT FAMILY	SCALE	SIZE	DWG. NO.	REV	SHEET
		SEE NOTE ①	DR. H. KAWAGUCHI	8/17/95		68P DOUBLE EJECTOR HEADER ASSY FOR TYPE 1/II/III	Header PCMCIA	2/1	C	92194	C	9 of