

PRODUCT NO.
92193

S		Revision Transfer to Nantong		J05-0215	M.H	4/25/06	REVISIONS			
REV	DESCRIPTION	ECN	BY	DATE						
T	REVISD (ADDED -*****LF)	N05-0127	WB	05/18/06						
U	ADD NEW P/N -120CAHLF	N07-0026	DT	1/29/07						
V	CORRECT WRONG DRAWING	N09-0163	SJH	6/3/09						
B	REVISED	130128	M.K	1/21/04						
C	REVISED	V40163	M.K	5/26/04						
D	REVISED	V40740	M.K	6/24/04						
E	REVISED	V40840	M.K	7/5/04						
F	REVISED	V40198	M.K	7/19/04						
G	REVISED	V32120	M.K	12/27/04						
H	REVISED	V40349	M.K	1/20/05						
J	REVISED	V50242	M.K	1/18/05						
K	REVISED	V60956	M.K	7/29/06						
L	REVISED (ADDED-050CAH -130CA -130CAH)	U70134	K.S	8/8/07						
M	REVISED	N90076	M.K	7/22/09						
N	REVISED (ADDED-502FA)	N19159	M.K	11/11/09						
P	REVISED	025-0198	M.H	4/7/05						
R	REVISED	W04-0826	M.H	4/25/05						

PRODUCT NO.	STAND	DIM "N"	PUSH ROD	HDR	HOLD DOWN	MECH ASSY	HDR ASSY	DIM "P"	HDR	SHEET	MOUNT STYLE TO PCB
92193-XXXXX	OFF(mm)	(mm)	COLOR	SOLDER TAIL		92192-XXXXX	92140-XXXX	(mm)	COLOR	NO.	& DIRECTION OF PUSH ROD
000AA	0	8	BLACK	R/A	NONE	00AA	000	2.8			
000CA	0	13	BLACK	R/A	NONE	00CA	000	2.8			
000CAH	0	13	BLACK	R/A	YES	00CAH	000H	2.8			
000CB	0	13	BLUE	R/A	NONE	00CB	000	2.8			
000CBH	0	13	BLUE	R/A	YES	00CBH	000H	2.8			
000FA	0	21	BLACK	R/A	YES	00FA	000	2.8			
001AA	0	8	BLACK	SMT STAGGERED	NONE	00AA	001	-	BLACK	NO.2	TOP MOUNT TO PCB & RIGHT PUSH ROD
001AAH	0	8	BLACK	SMT STAGGERED	YES	00AAH	001H	-			
001CA	0	13	BLACK	SMT STAGGERED	NONE	00CA	001	-			
001CAH	0	13	BLACK	SMT STAGGERED	YES	00CAH	001H	-			
001FA	0	21	BLACK	SMT STAGGERED	NONE	00FA	001	-			
001FAH	0	21	BLACK	SMT STAGGERED	YES	00FAH	001H	-			
002CA	0	13	BLACK	SMT IN LINE	NONE	00CA	002	-			
002CAH	0	13	BLACK	SMT IN LINE	YES	00CAH	002H	-			
020CA	2	13	BLACK	R/A	NONE	02CA	040	2.5			
040CA	4	13	BLACK	R/A	NONE	04CA	010	2.8			
050CA	5	13	BLACK	R/A	NONE	05CA	020	2.8			
050CAH	5	13	BLACK	R/A	YES	05CAH	020H	2.8			
100CA	0	13	BLACK	R/A	NONE	10CA	000	2.8			
100CAH	0	13	BLACK	R/A	YES	10CAH	000H	2.8			
101CA	0	13	BLACK	SMT STAGGERED	NONE	10CA	001	-			
101CAH	0	13	BLACK	SMT STAGGERED	YES	10CAH	001H	-			
101FA	0	21	BLACK	SMT STAGGERED	NONE	10FA	001	-			
101FAH	0	21	BLACK	SMT STAGGERED	YES	10FAH	001H	-			
102CA	0	13	BLACK	SMT IN LINE	NONE	10CA	002	-			
102CAH	0	13	BLACK	SMT IN LINE	YES	10CAH	002H	-			
120CA	2	13	BLACK	R/A	NONE	12CA	040	2.5			
120FA	2	21	BLACK	R/A	NONE	12FA	040	2.5			
130CA	3	13	BLACK	R/A	NONE	13CA	050	2.8			
130CAH	3	13	BLACK	R/A	YES	13CAH	050H	2.8			
140CA	4	13	BLACK	R/A	NONE	14CA	010	2.8			
150CA	5	13	BLACK	R/A	NONE	15CA	020	2.8			
500CA	0	13	BLACK	R/A	NONE	10CA	500	2.8			
500CAH	0	13	BLACK	R/A	YES	10CAH	500H	2.8			
500FA	0	21	BLACK	R/A	NONE	10FA	500	2.8			
501CA	0	13	BLACK	SMT STAGGERED	NONE	10CA	501	-			
501CAH	0	13	BLACK	SMT STAGGERED	YES	10CAH	501H	-	NATURAL	NO.6	BOTTOM MOUNT TO PCB & RIGHT PUSH ROD
502CA	0	13	BLACK	SMT IN LINE	NONE	10CA	502	-			
502CAH	0	13	BLACK	SMT IN LINE	YES	10CAH	502H	-			
502FA	0	21	BLACK	SMT IN LINE	NONE	10FA	502	-			
520CA	2	13	BLACK	R/A	NONE	12CA	540	2.5			
540CA	4	13	BLACK	R/A	NONE	14CA	510	2.8			
550CA	5	13	BLACK	R/A	NONE	15CA	520	2.8			
600CA	0	13	BLACK	R/A	NONE	00CA	500	2.8			
600CAH	0	13	BLACK	R/A	YES	00CAH	500H	2.8			
601CA	0	13	BLACK	SMT STAGGERED	NONE	00CA	501	-			
601CAH	0	13	BLACK	SMT STAGGERED	YES	00CAH	501H	-			
602CA	0	13	BLACK	SMT IN LINE	NONE	00CA	502	-			
602CAH	0	13	BLACK	SMT IN LINE	YES	00CAH	502H	-			
620CA	2	13	BLACK	R/A	NONE	02CA	540	2.5			
640CA	4	13	BLACK	R/A	NONE	04CA	510	2.8			
650CA	5	13	BLACK	R/A	NONE	05CA	520	2.8			

△

△

△

△

△

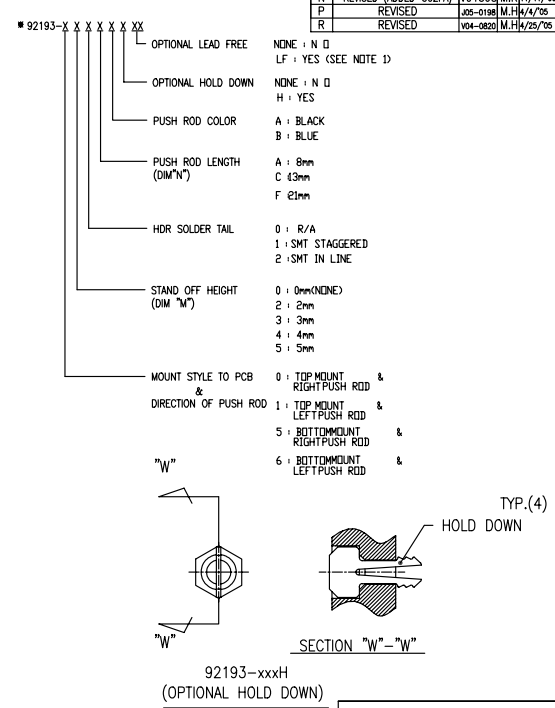
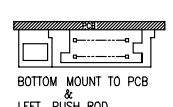
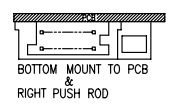
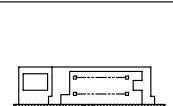
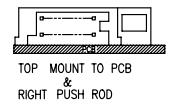

NOTE
1. THIS PRODUCT MEETS EUROPEAN UNION DIRECTIVES AND OTHER COUNTRY REGULATIONS AS DESCRIBED IN GS-22-008.

SHEET INDEX	ISSUE	DATE		CUSTOMER COPY		TITLE	
	SH NO.						
TOLERANCES UNLESS OTHERWISE SPECIFIED		MAT	DATE	CUSTOMER COPY		TITLE	
			04/18/06			68P EJECTOR HEADER ASSY FOR TYPE I/II/III (FOR 5.0V)	
LINEAR	FINISH	APPD	DATE	UNIT	SCALE	SIZE	DWG. NO.
			04/18/06				92193
ANGLES							



DO NOT SCALE PRINT THIS INFORMATION IS CONFIDENTIAL AND IS DISCLOSED TO YOU ON CONDITION THAT NO FURTHER DISCLOSURE IS MADE BY YOU TO OTHER THAN FCJ PERSONNEL WITHOUT WRITTEN AUTHORIZATION FROM FCJ JAPAN K.K.

PRODUCT NO.
92193-00*****

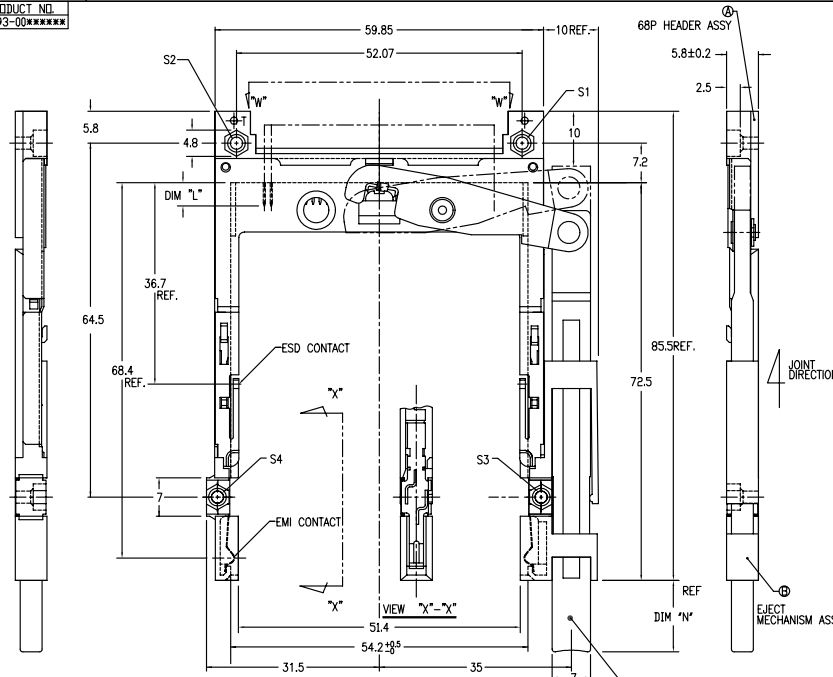

REVISIONS			
REV	DESCRIPTION	ECN	BY DATE
L	REVISED	J05-0198	M.H. 4/4/95
M	REVISED	104-0820	M.H. 4/25/95
T	REVISED (ADDED -*****LF)	105-0127	RB 1/25/98/95
U	REVISED		
V	REVISED		
G	REVISED	J40198	M.K. 1/29/94
H	REVISED	J40349	M.K. 1/9/95
J	REVISED	J50242	M.K. 1/18/95
K	REVISED	J70134	K.S. 8/8/97

PRODUCT NO.	REVISION
92193-000AA/000AALF	△
92193-000CA/000CALF	△
92193-000CB/000CBLF	△
92193-000CH/000CHLF	△
92193-000FA/000FALF	△

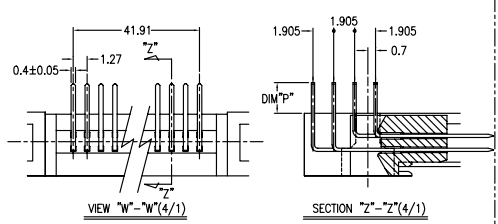

PRODUCT NO.	REVISION
92193-001AA	△
92193-001AAH	△
92193-001CA	△
92193-001CAH	△
92193-001FA	△
92193-001FAH	△

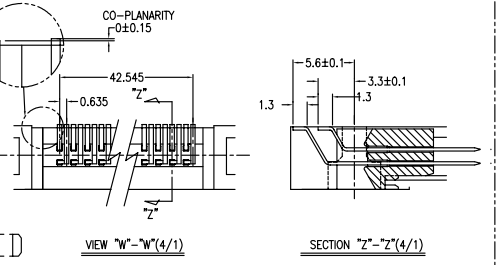

PRODUCT NO.	REVISION
92193-002CA	△
92193-002CAH	△

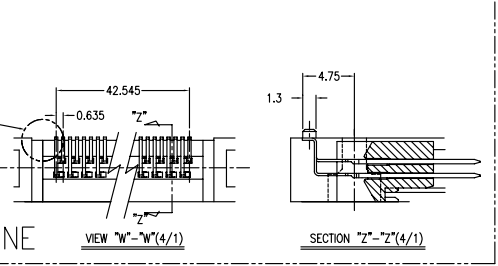

- NOTE
- EJECT FORCE 3.5Kg MAX.
 - ASSY PROCESS
 - TO MOUNT PART (A) ON PWB WITH SCREW (S1,S2) AND SOLDER.
 - TO JOINT PART (B) INTO PART (A), THEN FIX PART (B) WITH 2 SCREWS (S3,S4).
 - EJECT TRAVEL 8.0mm
- (A) MATERIAL
- PART (A) (HEADER ASSY)
 - HOUSING : LCP UL94V-0
 - PIN : PHOSPHOR BRONZE
 - PART (B) (EJECT MECHANISM ASSY)
 - GUIDE : POLYPHTHARAMID UL94V-0 BLACK
 - PUSH ROD : FLAME RETARDANT UL94V-0
 - PLATE : STAINLESS
 - EMI CONTACT : PHOSPHOR BRONZE
 - OPTIONAL HOLD-DOWN : BRASS

- FINISH 5.1 PIN
- EMI CONTACT
 - UNDER PLATING : 0.5µm MIN. Ni
 - CONTACT AREA : 0.1µm MIN. Au OVER 0.5µm MIN. Pd-Ni
 - SOLDER TAIL : 2.5µm MIN. Sn-Pb OR 2.5µm MIN. PURE Sn.(FOR -*****LF)
- OPTIONAL HOLD-DOWN : 2.5µm MIN. PURE Sn.

PIN NO.	DIM "L"	DIM "N"
1-35	4.25±0.1	3.5±0.1
36-67	3.67	1.724
68		3.21±0.08

- SEE TA-946 FOR PCB LAYOUT.
- SEE 92140 FOR DETAILED HDR DIMENSION.
- SEE SHEET 1,2 REGARDING COMPONENTS.
- GENERAL TOLERANCE : ±0.3

DO NOT SCALE PRINT THIS INFORMATION IS CONFIDENTIAL AND IS DISCLOSED TO YOU ON CONDITION THAT NO FURTHER DISCLOSURE IS MADE BY YOU TO OTHER THAN FCJ PERSONNEL WITHOUT WRITTEN AUTHORIZATION FROM FCJ JAPAN K.K.

SHEET INDEX	ISSUE SH. NO.	DATE	CUSTOMER COPY	TITLE	PRODUCT FAMILY	SCALE	SIZE	DWG. NO.	REV SHEET
		1/25/05		68P EJECTOR HEADER ASSY FOR TYPE I/II/III (FOR 5.0V)	Header PCMCIA	2/1	C	92193	3 OF

PDM: Rev:V STATUS Released Printed: Oct 12, 2010

PRODUCT NO.
92193-020CA/020CALF
92193-040CA/040CALF
92193-050CA/050CALF
92193-050CAH/050CAHLF

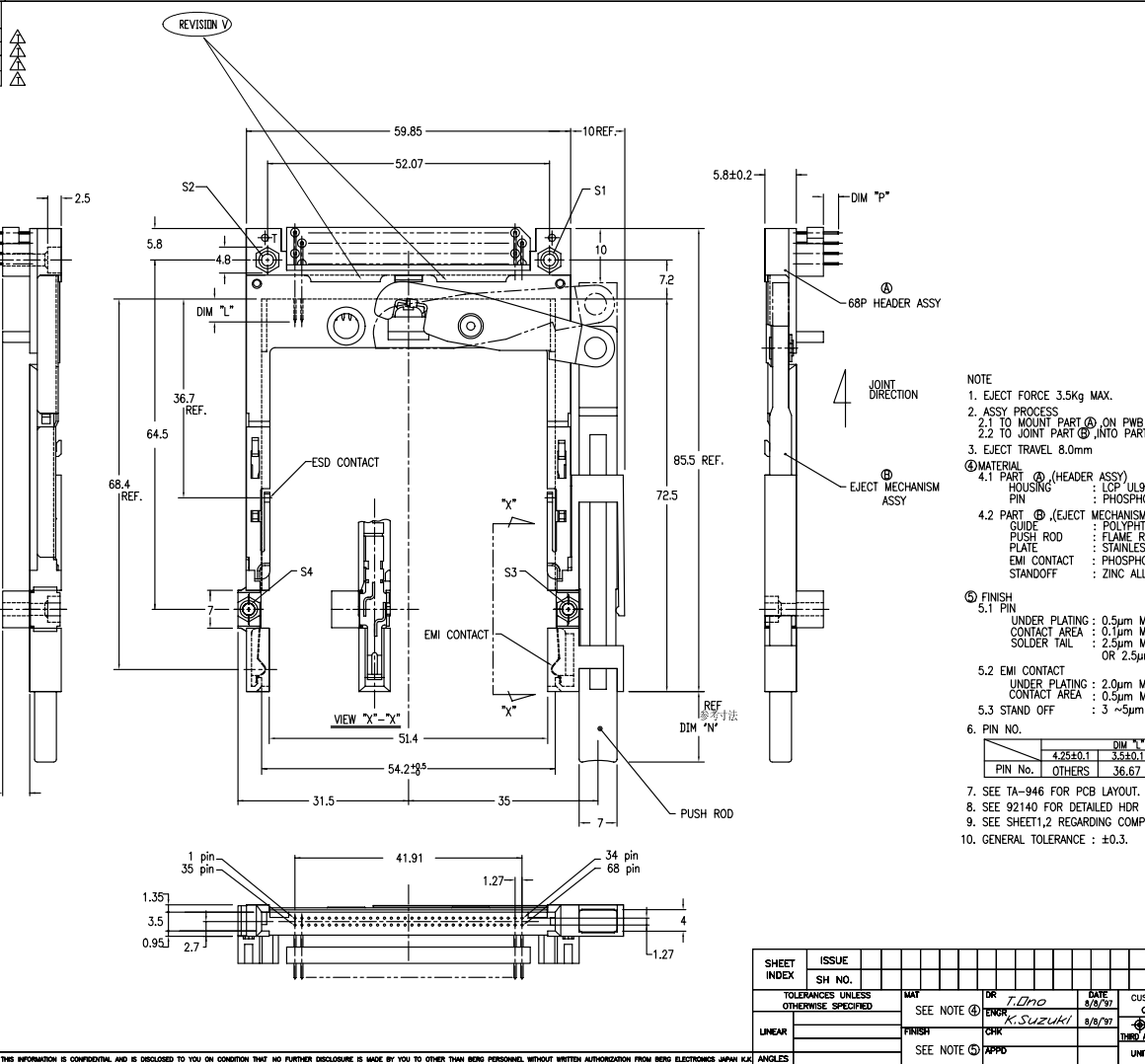

REVISIONS				
REV	DESCRIPTION	ECN	BY	DATE
A	RELEASED	J30022	N.T	0/19/93
B	REVISED	J40163	M.K	5/28/94
C	REVISED	V40840	M.K	7/ 5/94
D	REVISED	V32120	M.K	12/21/94
E	REVISED	J40349	M.K	1/19/95
F	REVISED	J50242	M.K	1/18/95
G	REVISED (ADDED-050CAH)	J70134	K.S	1/18/97
T	REVISED (ADDED -*****LF)	M5-0127	W6	1/25/18/95
U				
V				

- NOTE
- EJECT FORCE 3.5Kg MAX.
 - ASSY PROCESS
2.1 TO MOUNT PART ② ON PWB WITH SCREW (S1,S2) AND SOLDER
2.2 TO JOINT PART ③ INTO PART ② THEN FIX PART ② WITH 2 SCREWS (S3,S4).
 - EJECT TRAVEL 8.0mm
 - MATERIAL
4.1 PART ② (HEADER ASSY)
HOUSING : LCP UL94V-0
PIN : PHOSPHOR BRONZE
4.2 PART ③ (EJECT MECHANISM ASSY)
GUIDE : POLYPHTHALAMID UL94V-0 BLACK
PUSH ROD : FLAME RETARDANT UL94V-0
PLATE : STAINLESS
EMI CONTACT : PHOSPHOR BRONZE
STANDOFF : ZINC ALLOYS DIE CASTING
 - FINISH
5.1 PIN
UNDER PLATING : 0.5µm MIN. Ni
CONTACT AREA : 0.1µm MIN. Au OVER 0.5µm MIN. Pd-Ni
SOLDER TAIL : 2.5µm MIN. Sn-Pb
OR 2.5µm MIN. PURE Sn.(FOR -*****LF)
5.2 EMI CONTACT
UNDER PLATING : 2.0µm MIN. Ni
CONTACT AREA : 0.5µm MIN. Au
5.3 STAND OFF : 3 ~5µm Ni, OVER 5 ~10µm Cu.
 - PIN NO.
- | | | DIM "L" | |
|---------|--------|---------|-----------|
| PIN No. | OTHERS | 3,5±0.1 | 5,0±0.1 |
| | | 36.67 | 35.51±0.8 |
- SEE TA-946 FOR PCB LAYOUT.
 - SEE 92140 FOR DETAILED HDR DIMENSION.
 - SEE SHEET1,2 REGARDING COMPONENTS.
 - GENERAL TOLERANCE : ±0.3.

DF-003A REV C
DO NOT SCALE PRINT THIS INFORMATION IS CONFIDENTIAL AND IS DISCLOSED TO YOU ON CONDITION THAT NO FURTHER DISCLOSURE IS MADE BY YOU TO OTHER THAN BENG PERSONNEL WITHOUT WRITTEN AUTHORIZATION FROM BENG ELECTRONICS JAPAN K.K.

SHEET INDEX	ISSUE	DATE	CUSTOMER	TITLE
SH NO.	SH NO.	DATE	COPY	68P EJECTOR HEADER ASSY FOR TYPE I/II/III (FOR 5.0V)
TOLERANCES UNLESS OTHERWISE SPECIFIED	MAT	DR	DATE	CUSTOMER
SEE NOTE ④	ENGR	T.DMO	8/8/97	COPY
LINEAR	FINISH	CHK	8/8/97	THRO ANGLE PRO
SEE NOTE ⑤	APPD			UNIT
ANGLES				SCALE
				SIZE DWG. NO.
				92193
				REV SHEET
				4 of

PDM: Rev:V STATUS Released Printed: Oct 12, 2010

PRODUCT NO.	92193-101FA
92193-100CA/100CALF	92193-101FAH
92193-100CAH/100CAHL	92193-102CA
92193-101CA	92193-102CAH
92193-101CAH	

		REVISIONS			
REV	DESCRIPTION	ECN	BY	DATE	
F	REVISED	J40198	M.K	7/19/94	
F	REVISED	132120	M.K	2/27/94	
G	REVISED	J40349	M.K	1/9/95	
H	REVISED	J50242	M.K	9/18/95	
J	REVISED	J70134	K.S	8/8/97	

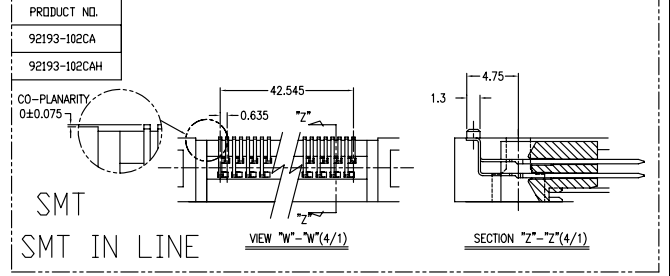
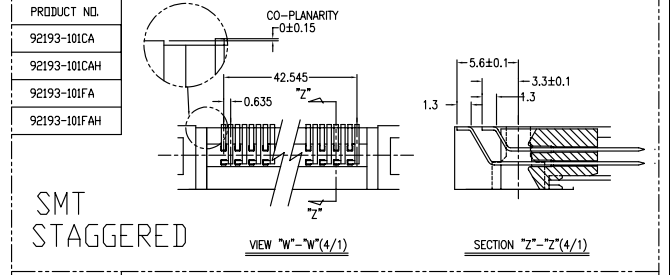
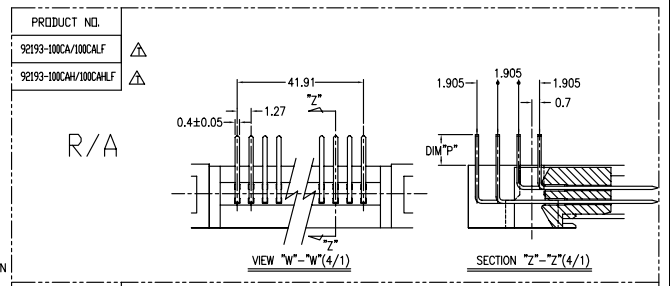
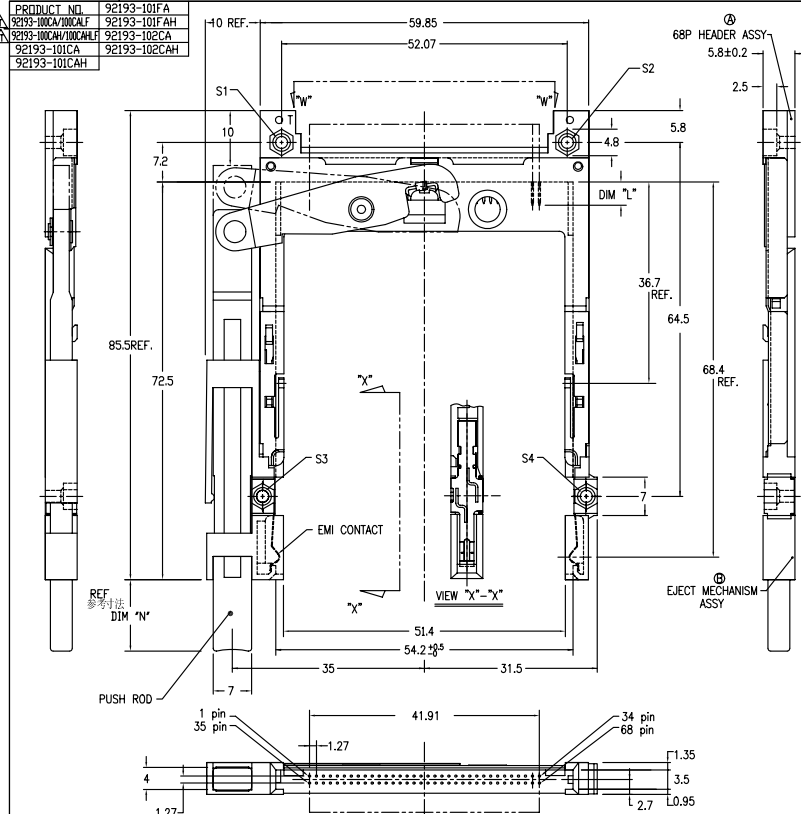

- NOTE
- EJECT FORCE 3.5Kg MAX.
 - ASSY PROCESS
2.1 TO MOUNT PART ④ ON PWB WITH SCREW (S1,S2) AND SOLDER.
2.2 TO JOINT PART ④ INTO PART ④, THEN FIX PART ④ WITH 2 SCREWS (S3,S4).
 - EJECT TRAVEL 8.0mm
- ④ MATERIAL
- PART ④ (HEADER ASSY)
HOUSING : LCP UL94V-0
PIN : PHOSPHOR BRONZE
 - PART ④ (EJECT MECHANISM ASSY)
GUIDE : POLYPHTHALAMID UL94V-0 BLACK
PUSH ROD : FLAME RETARDANT UL94V-0
PLATE : STAINLESS
EMI CONTACT : PHOSPHOR BRONZE
4.3 OPTIONAL HOLD-DOWN : BRASS
- ⑤ FINISH 5.1 PIN
- UNDER PLATING : 0.5µm MIN. Ni
CONTACT AREA : 0.1µm MIN. Au OVER 0.5µm MIN. Pd-Ni
SOLDER TAIL : 2.5µm MIN. Sn-Pb OR 2.5µm MIN. PURE Sn.(FOR -*****LF)
- 5.2 EMI CONTACT
UNDER PLATING : 2.0µm MIN. Ni
CONTACT AREA : 0.5µm MIN. Au
- 5.3 OPTIONAL HOLD-DOWN : 2.5µm MIN. PURE Sn
6. PIN NO.
- | | DIM "X" | | |
|---------|----------|---------|---------|
| | 4.25±0.1 | 3.5±0.1 | 5.0±0.1 |
| PIN No. | OTHERS | 36.67 | 11.74 |
| | | | 35±0.08 |
- SEE TA-946 FOR PCB LAYOUT.
 - SEE 92140 FOR DETAILED HDR DIMENSION.
 - SEE SHEET 1, 2 REGARDING COMPONENTS.
 - GENERAL TOLERANCE : ±0.3

SHEET INDEX	ISSUE	DATE	CUSTOMER	TITLE
				68P EJECTOR HEADER ASSY FOR TYPE 1/1/1 (FOR 5.0V)
				SCALE: SIZE DWG. NO. 92193
				REV SHEET 15 OF 15

PDM: Rev:V STATUS Released Printed: Oct 12, 2010

PRODUCT NO.
92193-120CA/120CAHLF
92193-120FA/120FALF
92193-130CA/130CALF
92193-130CAH/130CAHLF
92193-140CA/140CALF
92193-150CA/150CALF

REVISIONS				
REV	DESCRIPTION	ECN	BY	DATE
A	RELEASED	J30022	N.T	0/19/93
B	REVISED	J40163	M.K	5/28/94
C	REVISED	V40840	M.K	7/ 5/94
D	REVISED	V32120	M.K	12/27/94
E	REVISED	J40349	M.K	1/9/95
F	REVISED	J50242	M.K	9/18/95
G	REVISED ADDED-130CA -130CAH	J70134	K.S	8/8/97
H	REVISED	N80076	M.K	7/22/99
T	REVISED ADDED -*****F	M5-0127	MB	05/18/05
U				
V				

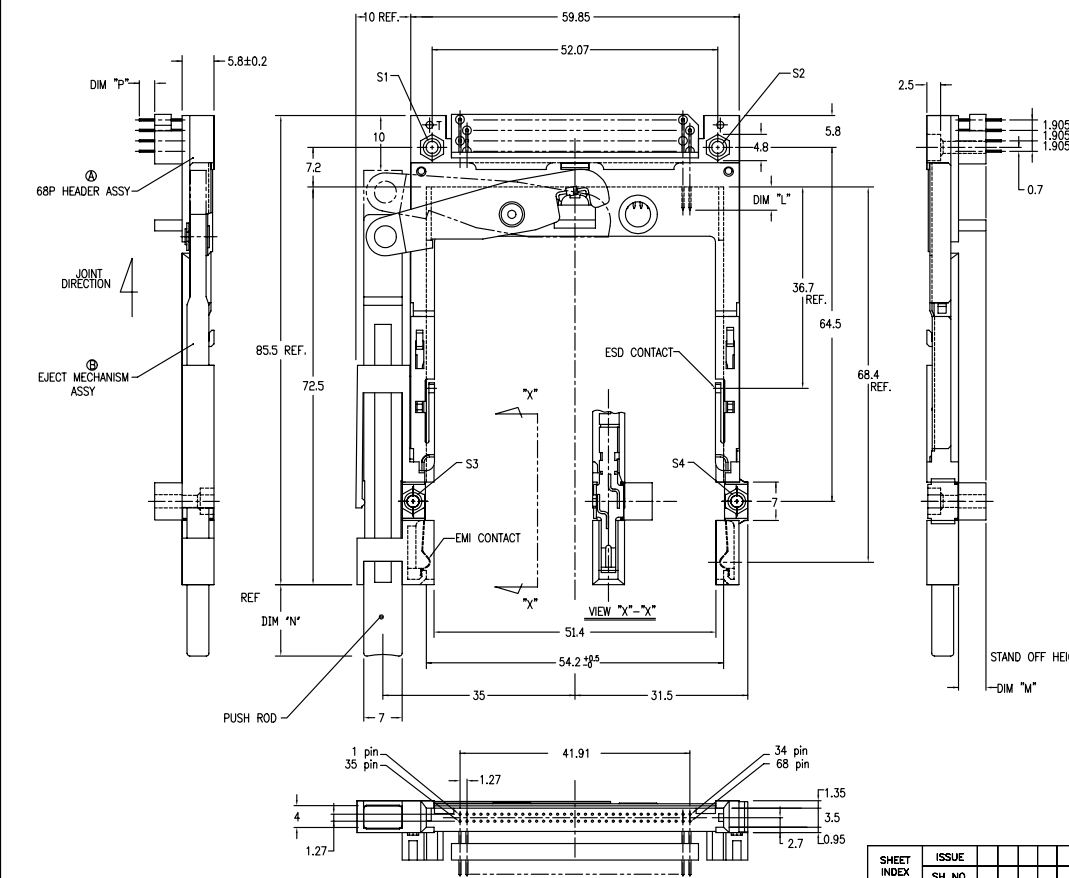

- NOTE
- EJECT FORCE 3.5Kg MAX.
 - ASSY PROCESS
 - TO MOUNT PART ④ ON PWB WITH SCREW (S1,S2) AND SOLDER
 - TO JOINT PART ⑤ INTO PART ④, THEN FIX PART ④ WITH 2 SCREWS (S3,S4).
 - EJECT TRAVEL 8.0mm
 - MATERIAL
 - PART ④ (HEADER ASSY)
 - HOUSING : LCP UL94V-0
 - PIN : PHOSPHOR BRONZE
 - PART ⑤ (EJECT MECHANISM ASSY)
 - GUIDE : POLYPHTHALAMID UL94V-0 BLACK
 - PUSH ROD : FLAME RETARDANT UL94V-0
 - PLATE : STAINLESS
 - EMI CONTACT : PHOSPHOR BRONZE
 - STANDOFF : ZINC ALLOYS DIE CASTING
 - FINISH
 - PIN
 - UNDER PLATING : 0.5µm MIN. Ni
 - CONTACT AREA : 0.1µm MIN. Au OVER 0.5µm MIN. Pd-Ni
 - SOLDER TAIL : 2.5µm MIN. Sn-Pb
 - OR 2.5µm MIN. PURE Sn.(FOR -*****LF)
 - EMI CONTACT
 - UNDER PLATING : 2.0µm MIN. Ni
 - CONTACT AREA : 0.5µm MIN. Au
 - STAND OFF : 3 ~5µm Ni, OVER 5 ~10µm Cu.
 - PIN NO.

PIN NO.	DIM "M"		DIM "N"
	4.25±0.1	3.5±0.1	
OTHERS	36.67	35.27±0.08	
7. SEE TA-946 FOR PCB LAYOUT.
 8. SEE 92140 FOR DETAILED HDR DIMENSION.
 9. SEE SHEET.2 REGARDING COMPONENTS.
 10. GENERAL TOLERANCE : ±0.3.

DF-003A REV. C

DO NOT SCALE PRINT THIS INFORMATION IS CONFIDENTIAL AND IS DISCLOSED TO YOU ON CONDITION THAT NO FURTHER DISCLOSURE IS MADE BY YOU TO OTHER THAN BIRD PERSONNEL WITHOUT WRITTEN AUTHORIZATION FROM BIRD ELECTRONICS JAPAN K.K.

SHEET INDEX	ISSUE	SH. NO.	DATE	CUSTOMER COPY	TITLE	SCALE	SIZE	DWG. NO.	REV	SHEET
			DATE		68P EJECTOR HEADER ASSY FOR TYPE 1/L/ (FOR 5.0V)	2/1	C	92193	V	6 OF

PDM: Rev:V STATUS Released Printed: Oct 12, 2010

PRODUCT NO.	92193-501CA
△ 92193-500CA/500CALF	92193-501CAH
△ 92193-500CAH/500CAHLF	92193-502CA
△ 92193-500FA/500FALF	92193-502CAH
	92193-502FA

REVISIONS			
REV	DESCRIPTION	ECN	BY DATE
K	REVISED	V81595	M.K. 11/11/99
L	REVISED (ADDED -*****LF)	N65-0122	HB 1/25/18/95
M	REVISED		
N	REVISED		
O	REVISED		
P	REVISED		
Q	REVISED		
R	REVISED		
S	REVISED		
T	REVISED		
U	REVISED		
V	REVISED		

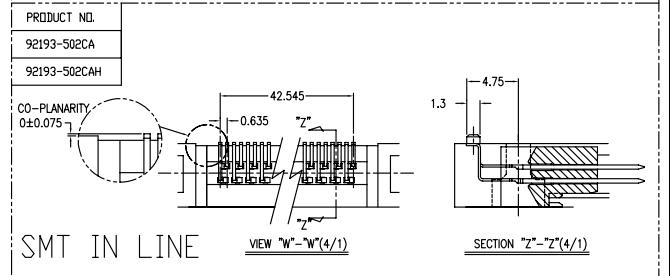
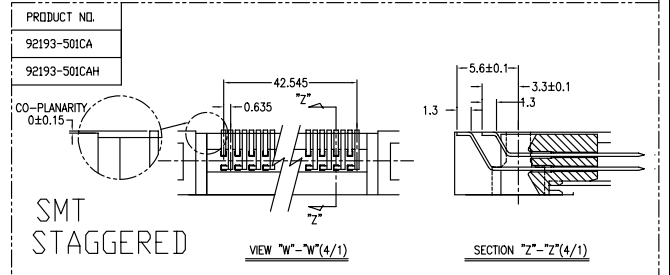
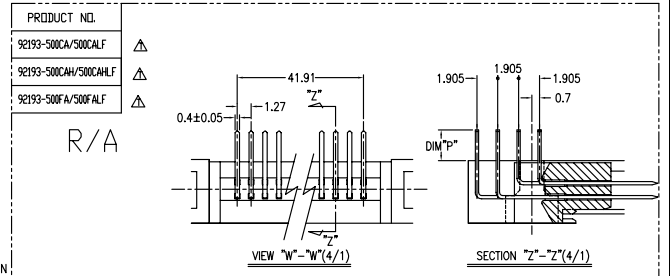
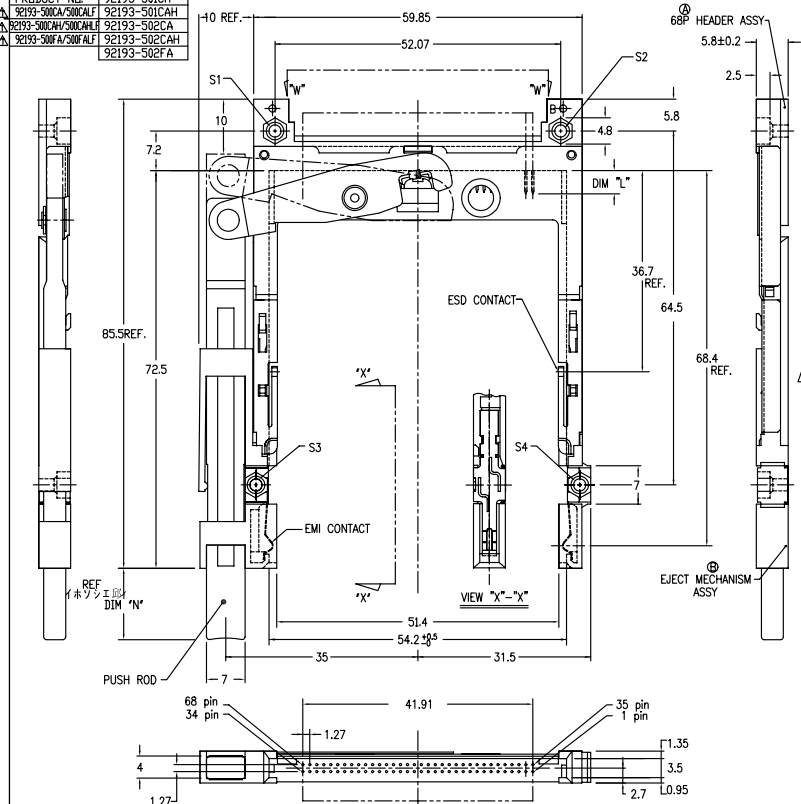

- NOTE
- EJECT FORCE 3.5kg MAX.
 - ASSY PROCESS
 - TO MOUNT PART ④ ON PWB WITH SCREW (S1,S2) AND SOLDER.
 - TO JOINT PART ④ INTO PART ④, THEN FIX PART ④ WITH 2 SCREWS (S3,S4).
 - EJECT TRAVEL 8.0mm
- ④ MATERIAL
- PART ④ (HEADER ASSY)
 - HOUSING : LCP UL94V-0
 - PIN : PHOSPHOR BRONZE
 - PART ④ (EJECT MECHANISM ASSY)
 - GUIDE : POLYPHTHALAMID UL94V-0 BLACK
 - PUSH ROD : FLAME RETARDANT UL94V-0
 - PLATE : STAINLESS
 - EMI CONTACT : PHOSPHOR BRONZE
 - OPTIONAL HOLD-DOWN : BRASS
- ⑤ FINISH
- 5.1 PIN
 - UNDER PLATING : 0.5µm MIN. Ni
 - CONTACT AREA : 0.1µm MIN. Au OVER 0.5µm MIN. Pd-Ni
 - SOLDER TAIL : 2.5µm MIN. Sn-Pb OR 2.5µm MIN. PURE Sn (FOR -*****LF)
 - 5.2 EMI CONTACT
 - UNDER PLATING : 2.0µm MIN. Ni
 - CONTACT AREA : 0.5µm MIN. Au
 - 5.3 OPTIONAL HOLD-DOWN : 2.5µm MIN. PURE Sn
6. PIN NO.
- | | DIM 'L' | |
|----------|---------|----------|
| PIN NO. | OTHERS | 36.67 |
| 4,25±0.1 | 3.5±0.1 | 5.0±0.1 |
| | | 1.7±0.4 |
| | | 35.5±0.8 |
- SEE TA-946 FOR PCB LAYOUT.
 - SEE 92140 FOR DETAILED HDR DIMENSION.
 - SEE SHEET 2 REGARDING COMPONENTS.
 - GENERAL TOLERANCE : ±0.3.

SHEET INDEX	ISSUE SH NO.	MAT	DR	CHK	APPD	DATE	CUSTOMER COPY	TITLE	SCALE	SIZE	DWG. NO.	REV	SHEET
			T. Uno	M. K. Kurai		11/11/99		68P EJECTOR HEADER ASSY FOR TYPE I/II/III (FOR 5.0V)	2/1	C	92193	V	17 OF

PDM: Rev:V STATUS Released Printed: Oct 12, 2010

PRODUCT NO.	
92193-520CA/520CALF	△
92193-540CA/540CALF	△
92193-550CA/550CALF	△

REVISIONS				
REV	DESCRIPTION	ECN	BY	DATE
A	RELEASED	J30022	N.T	01/19/93
B	REVISED	J30128	M.N	02/27/93
C	REVISED	J40163	M.K	5/26/94
D	REVISED	V40840	M.K	7/ 5/94
E	REVISED	V32120	M.K	12/27/94
F	REVISED	J40349	M.K	1/9/94
G	REVISED	J50242	M.K	8/18/95
T	REVISED (ADDED -*****L)	N65-0127	W6	3/25/18/95
U				
V				

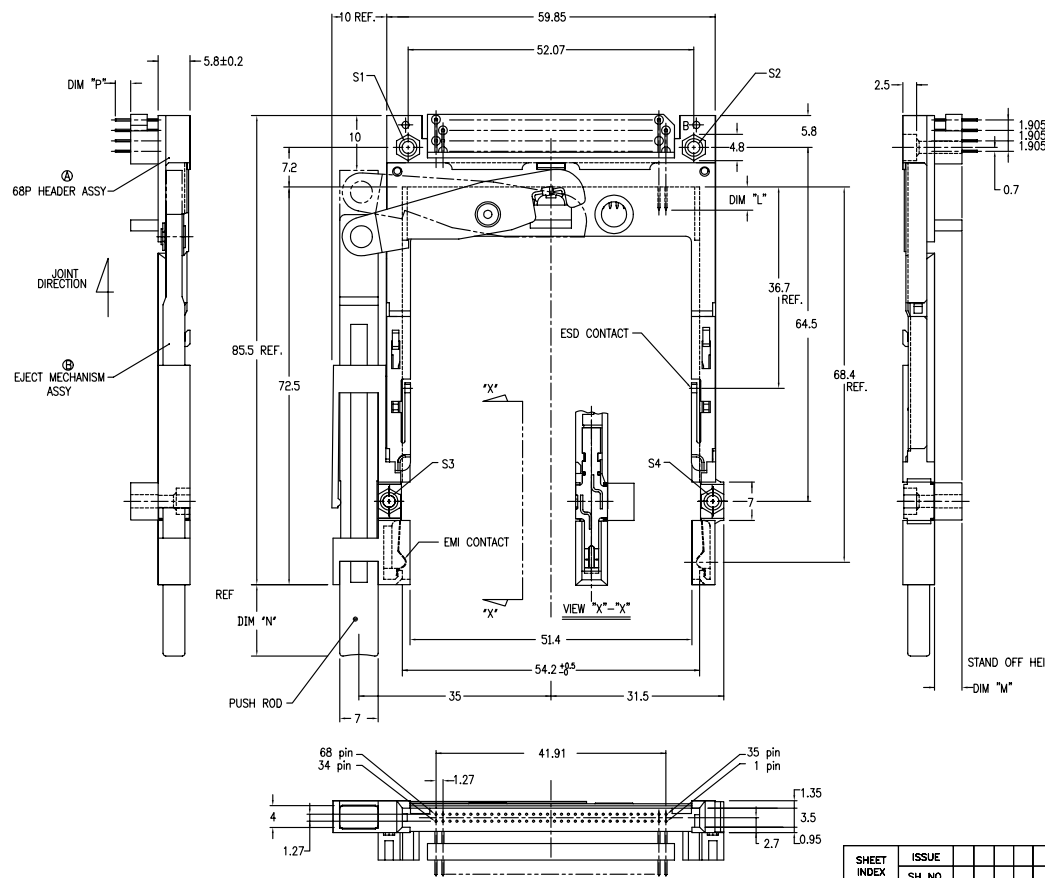

NOTE

- EJECT FORCE 3.5Kg MAX.
- ASSY PROCESS
 - TO MOUNT PART ① ON PWB WITH SCREW (S1,S2) AND SOLDER.
 - TO JOINT PART ② INTO PART ③, THEN FIX PART ④ WITH 2 SCREWS (S3,S4)
- EJECT TRAVEL 8.0mm
- MATERIAL
 - PART ① (HEADER ASSY)
 - HOUSING : LCP UL94V-0
 - PIN : PHOSPHOR BRONZE
 - PART ② (EJECT MECHANISM ASSY)
 - GUIDE : POLYPHTHARAMID UL94V-0 BLACK
 - PUSH ROD : FLAME RETARDANT UL94V-0
 - PLATE : STAINLESS
 - EMI CONTACT : PHOSPHOR BRONZE
 - STANDOFF : ZINC ALLOYS DIE CASTING
- FINISH
 - PIN
 - UNDER PLATING : 0.5µm MIN. Ni
 - CONTACT AREA : 0.1µm MIN. Au OVER 0.5µm MIN. Pd-Ni
 - SOLDER TAIL : 2.5µm MIN. Sn-Pb OR 2.5µm MIN. PURE Sn.(FOR -*****L)
 - EMI CONTACT
 - UNDER PLATING : 2.0µm MIN. Ni
 - CONTACT AREA : 0.5µm MIN. Au
 - STAND OFF : 3 ~ 5µm Ni OVER 5 ~ 10µm Cu.
- PIN NO.

7. SEE TA-946 FOR PCB LAYOUT.
 8. SEE 92140 FOR DETAILED HDR DIMENSION.
 9. SEE SHEET 1,2 REGARDING COMPONENTS.
 10. GENERAL TOLERANCE : ±0.3.

DO NOT SCALE PRINT THIS INFORMATION IS CONFIDENTIAL AND IS DISCLOSED TO YOU ON CONDITION THAT NO FURTHER DISCLOSURE IS MADE BY YOU TO OTHER THAN BENG PERSONNEL WITHOUT WRITTEN AUTHORIZATION FROM BENG ELECTRONICS JAPAN K.K.

SHEET INDEX	ISSUE										
	SH NO.										
TOLERANCES UNLESS OTHERWISE SPECIFIED		MAT	DR	DATE	CUSTOMER	TITLE					
			T. Imaeda	9/19/95	COPY	68P EJECTOR HEADER ASSY FOR TYPE I/II/III (FOR 5.0V)					
LINEAR		FINISH	CHK	M.Ka. Iwata	9/19/95	THRO ANGLE PRO	SCALE	SIZE	DWG. NO.	REV	SHEET
			SEE NOTE ①	APPD		UNIT	2/1	C	92193	V	8 of

PDM: Rev:V STATUS:Released Printed: Oct 12, 2010

PRODUCT NO.	92193-601CAH
92193-600CA/600CALF	92193-602CA
92193-600WH/600CHLF	92193-602CAH
92193-601CA	

T		REVISED (ADDED -*****LF)		WS-0127	WS	05/18/95
U						
V						

REVISIONS			
REV	DESCRIPTION	ECN	BY DATE
D	REVISED	140340	M.K.12/27/94
E	REVISED	132120	M.K.12/27/94
F	REVISED	140349	M.K.1/9/95
G	REVISED	150242	M.K.9/18/95
H	REVISED	170134	K.S.8/8/97

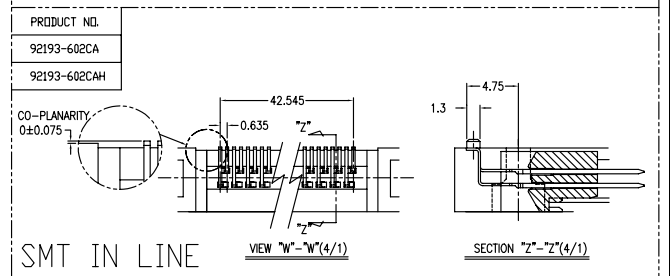
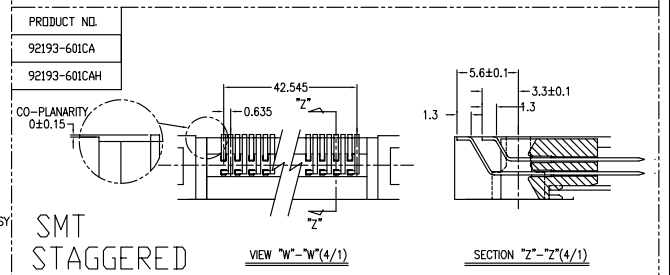
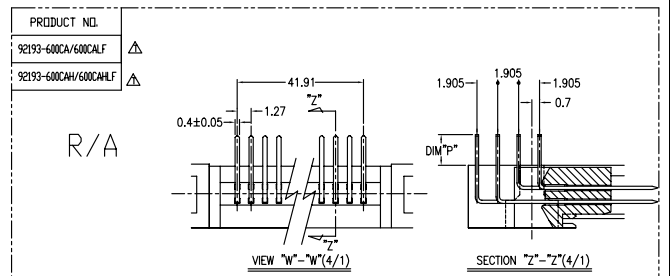
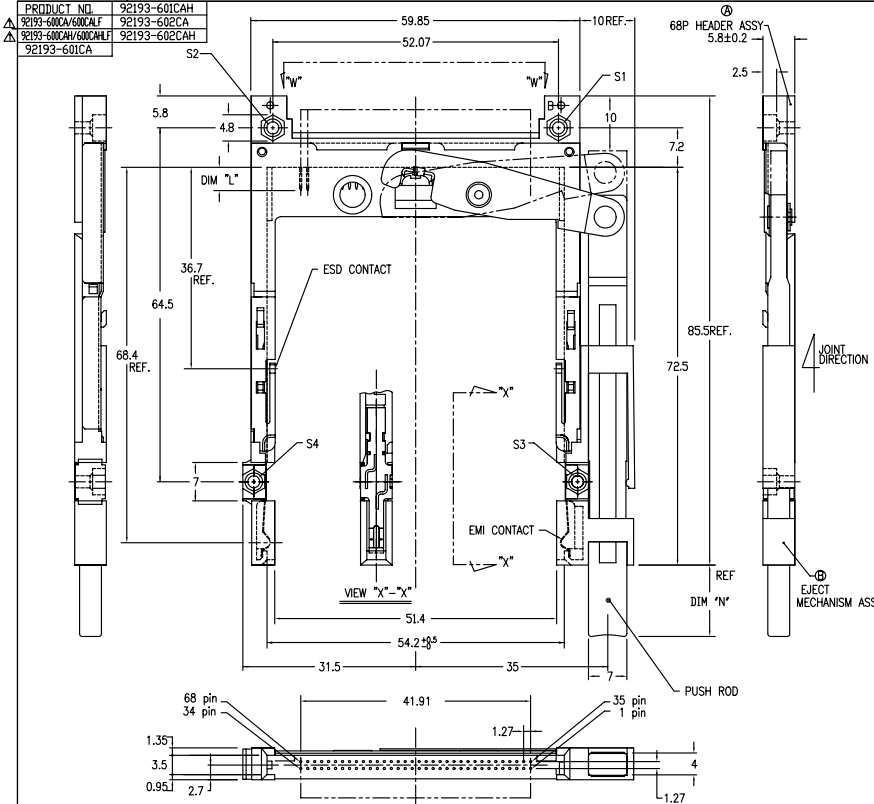

- NOTE
- EJECT FORCE 3.5Kg MAX.
 - ASSY PROCESS
 - TO MOUNT PART ② ON PWB WITH SCREW (S1,S2) AND SOLDER.
 - TO JOINT PART ③ INTO PART ②, THEN FIX PART ④ WITH 2 SCREWS (S3,S4).
 - EJECT TRAVEL 8.0mm
- ④ MATERIAL
- PART ② (HEADER ASSY)
 - HOUSING : LCP UL94V-0
 - PIN : PHOSPHOR BRONZE
 - PART ③ (EJECT MECHANISM ASSY)
 - GUIDE : POLYPHTHARAMID UL94V-0 BLACK
 - PUSH ROD : FLAME RETARDANT UL94V-0
 - PLATE : STAINLESS
 - EMI CONTACT : PHOSPHOR BRONZE
 - OPTIONAL HOLD-DOWN : BRASS
- ⑤ FINISH
- PIN
 - UNDER PLATING : 0.5µm MIN. Ni
 - CONTACT AREA : 0.1µm MIN. Au OVER 0.5µm MIN. Pd-Ni
 - SOLDER TAIL : 2.5µm MIN. Sn-Pb OR 2.5µm MIN. PURE Sn, (FOR -*****LF)
 - EMI CONTACT
 - UNDER PLATING : 2.0µm MIN. Ni
 - CONTACT AREA : 0.5µm MIN. Au
 - OPTIONAL HOLD-DOWN : 2.5µm MIN. PURE Sn
6. PIN NO.
- | | DIM 'L' | | |
|---------|----------|---------|---------|
| PIN No. | 4.25±0.1 | 3.5±0.1 | 5.0±0.1 |
| OTHERS | 36.67 | 17.94 | 35.168 |
- SEE TA-946 FOR PCB LAYOUT.
 - SEE 92140 FOR DETAILED HDR DIMENSION.
 - SEE SHEET 1.2 REGARDING COMPONENTS.
 - GENERAL TOLERANCE : ±0.3

SHEET INDEX	ISSUE	DATE	CUSTOMER	TITLE
				68P EJECTOR HEADER ASSY FOR TYPE 1/1/II (FOR 5.0V)

LINEAR	FINISH	SEE NOTE	DATE	UNIT	SCALE	SIZE	DWG. NO.	REV SHEET
		①	8/8/97	mm	2/1	C	92193	9 OF

DO NOT SCALE PRINT THIS INFORMATION IS CONFIDENTIAL AND IS DISCLOSED TO YOU ON CONDITION THAT NO FURTHER DISCLOSURE IS MADE BY YOU TO OTHER THAN BENG PERSONNEL WITHOUT WRITTEN AUTHORIZATION FROM BENG ELECTRONICS JAPAN K.K.

PRODUCT NO.
 Δ 92193-620CA/620CALF
 Δ 92193-640CA/640CALF
 Δ 92193-650CA/650CALF

REVISIONS				
REV	DESCRIPTION	ECN	BY	DATE
A	RELEASED	J33022	N.T	01/19/93
B	REVISED	J40163	M.K	5/28/94
C	REVISED	V40840	M.K	7/ 5/94
D	REVISED	V32120	M.K	12/21/94
E	REVISED	J40349	M.K	1/16/95
F	REVISED	J50242	M.K	9/18/95
T	REVISED (ADDED -*****LF)	M5-0127	MB	05/18/95
U				
V				

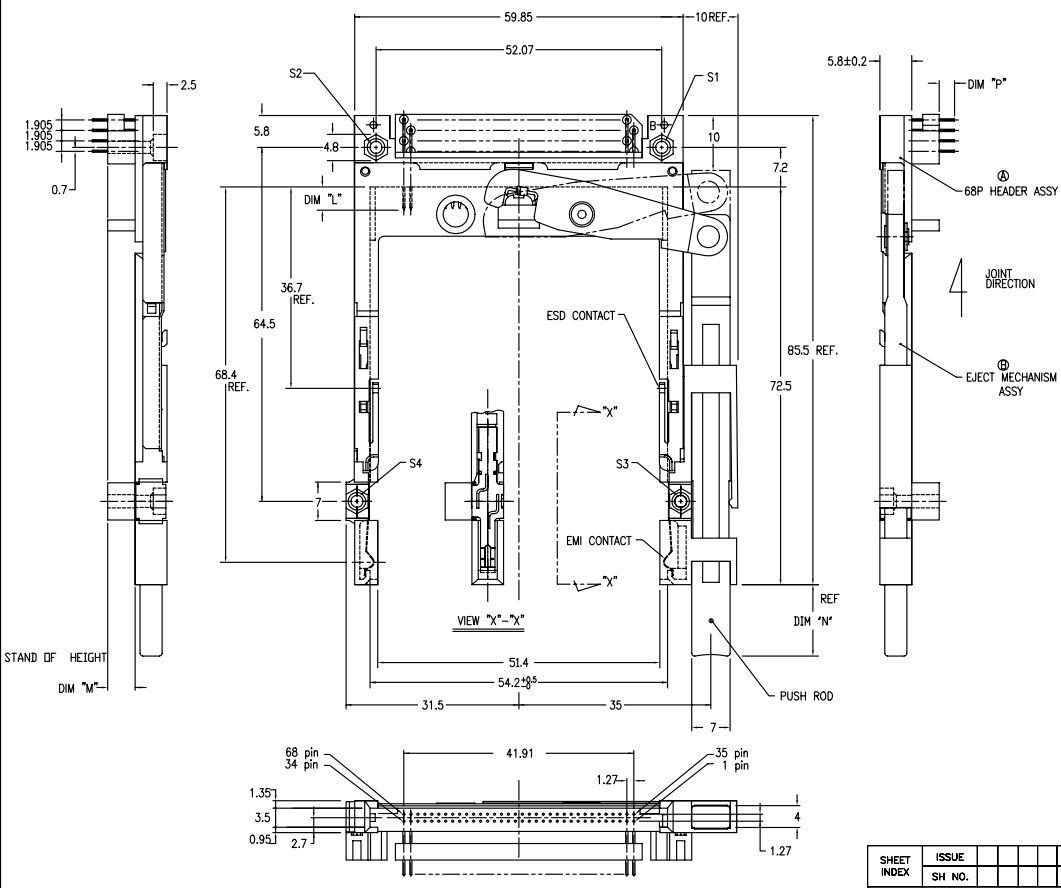

NOTE

- EJECT FORCE 3.5kg MAX.
- ASSY PROCESS
 2.1 TO MOUNT PART ② ON PWB WITH SCREW (S1,S2) AND SOLDER
 2.2 TO JOINT PART ③ INTO PART ②, THEN FIX PART ② WITH 2 SCREWS (S3,S4).
- EJECT TRAVEL 8.0mm
- MATERIAL
 ④ PART ② (HEADER ASSY)
 HOUSING : LCP UL94V-0
 PIN : PHOSPHOR BRONZE
 ④ PART ③ (EJECT MECHANISM ASSY)
 GUIDE : POLYETHYLENE TEREPHTHALATE UL94V-0 BLACK
 PUSH ROD : FLAME RETARDANT UL94V-0
 PLATE : STAINLESS
 EMI CONTACT : PHOSPHOR BRONZE
 STAND OFF : ZINC ALLOYS DIE CASTING
- FINISH
 5.1 PIN
 UNDER PLATING : 0.5μm MIN. Ni
 CONTACT AREA : 0.1μm MIN. Au OVER 0.5μm MIN. Pd-Ni
 SOLDER TAIL : 2.5μm MIN. Sn-Pb
 OR 2.5μm MIN. PURE Sn (FOR -*****LF)
 5.2 EMI CONTACT
 UNDER PLATING : 2.0μm MIN. Ni
 CONTACT AREA : 0.5μm MIN. Au
 5.3 STAND OFF : 3 ~5μm Ni, OVER 5 ~10μm Cu.
- PIN NO.

	DIM 'L'	DIM 'P'
4.25±0.1	3.5±0.1	5.0±0.1
PIN No.	36.67	33.5±0.08

- SEE TA-946 FOR PCB LAYOUT.
- SEE 92140 FOR DETAILED HDR DIMENSION.
- SEE SHEET 1,2 REGARDING COMPONENTS.
- GENERAL TOLERANCE : ±0.3

DF-003A REV. C
 DO NOT SCALE PRINT THIS INFORMATION IS CONFIDENTIAL AND IS DISCLOSED TO YOU ON CONDITION THAT NO FURTHER DISCLOSURE IS MADE BY YOU TO OTHER THAN BENG PERSONNEL WITHOUT WRITTEN AUTHORIZATION FROM BENG ELECTRONICS JAPAN K.K.

SHEET INDEX	ISSUE	SH NO.	DATE	CUSTOMER	TITLE
					68P EJECTOR HEADER ASSY FOR TYPE 1/L/II (FOR 5.0V)
LINEAR	FINISH	SEE NOTE ④	DR T. Imai ta 9/19/95	COPY	SCALE: 2/1
		SEE NOTE ④	CHK M. K. Iwata 9/18/95	UNIT	SIZE DWG. NO. 92193
			APPD	REV SHEET	V 10 of 10

PDM: Rev:V STATUS Released Printed: Oct 12, 2010