

PRODUCT NO.
SEE TABLE

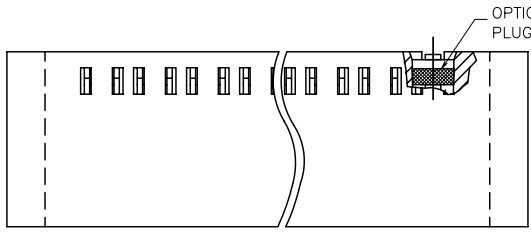

OPTIONAL INSULATION
PLUG

.046 SQUARE CONTACT
1.17 OPENING TYP

R .072 \pm .003
1.83 \pm .002 TYP
-0.02
+0.08
-0.05

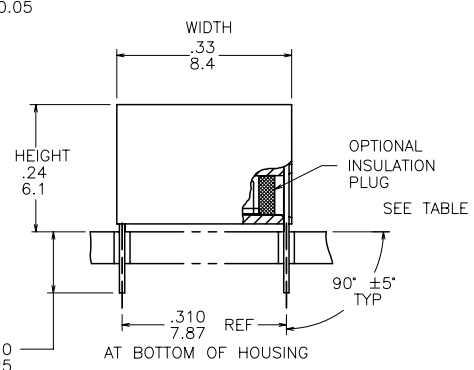
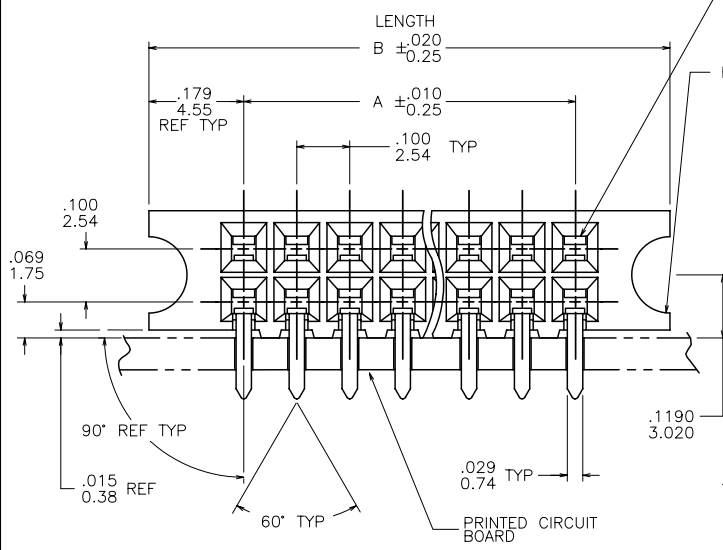

mat'l. code		surface ISO 1902		tolerance ISO 406 ISO 1101		projection		product family CARD CONN.	
lir	ec'n no	dr	date	tolerances unless otherwise specified		INCH/MM		title GUIDE PIN CARD CONNECTOR	
N	V61633	EPK	9/17/90	angles	linear	.XX \pm .01/.X40.3		dwg no 66527	
P	V70994	JM	10/19/97	0° \pm 2°		.XXX \pm .05/.XX40.13		sheet 1 of 6 size A3	
R	V02523	AZ	10/24/00			.XXX \pm .020/.XXX40.05		type Product Customer Drawing	
S	V21783	CGD	11/18/02	dr	C.DAILY	11/18/02			
T	M05-0113	MHT	6/14/05	engr	H.SUNDY	11/18/02			
U	M07-0137	MHT	2/26/07	chr	H.SUNDY	11/18/02			
V	M08-0232	MHT	8/14/08	appd	H.SUNDY	11/18/02			
sheet	revision	V	V	V	V	V	V		
index	sheet	1	2	3	4	5	6		

PDM: Rev:V STATUS:Released Printed: Oct 13, 2010

PRODUCT NO.
SEE TABLE

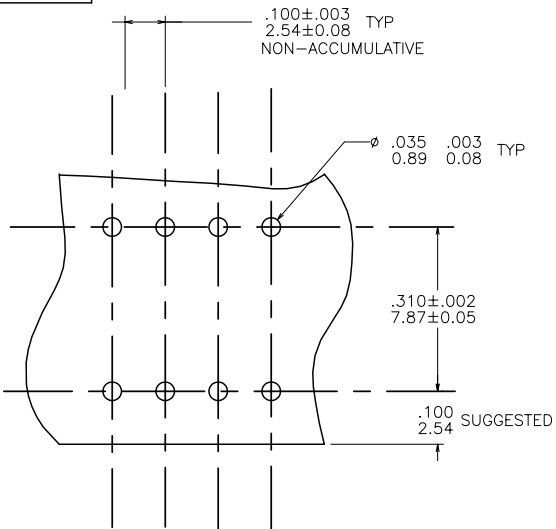

FIGURE 1

NOTES:

1. HOUSING MATERIAL:
FILLED HIGH TEMPERATURE NYLON
PER UL 94V-0
COLOR: BLACK
2. TERMINAL MATERIAL:
BODY: BRASS, .010/0.25 THICK
SPRING: BE-CU, HEAT TREATED
BODY PLATING DUPLEX :
30 MICROINCH/0.76 MICRON GOLD OR GXT
OVER 50 MICROINCH/1.27 MICRON NICKEL
IN CONTACT AREA
SOLDER TAIL : 100u"/2.54um PURE TIN MIN
OVER .050u"/1.27um NICKEL
SPRING PLATING: GOLD FLASH

3. MARK "FCI", FCI PART NUMBER AND DATE CODE.
LEGIBLE ON TUBE LABEL.
4. APPLICATION INFORMATION:
A. RECOMMENDED MOUNTING HOLE
PATTERN IS SHOWN IN FIGURE "1"
B. ALL MATING PINS TO BE .025/.64 SQUARE ON
TRUE CENTER OF GIVEN TERMINAL
SPACINGS WITHIN .015/0.38 DIA.
C. SUGGESTED MATING PIN LENGTH
.350±.020/8.89±0.51
5. MARK IN .060/1.52 HIGH LETTERS.(CONTRASTING
COLORS) - 9113 4445
FCI XXXX
DATE CODE
6. .003/0.08 THICK TERMINAL SPRING.
7. PACKAGING: STANDARD 24" LONG TUBES.
8. 550mm LONG SPECIAL SHORT TUBE PACKAGING:
ADD SUFFIX "A" TO PART DASH NUMBER. EXAMPLE: 66527-001A
9. ADD "LF" SUFFIX AT THE END OF PART NUMBER FOR
LEAD FREE OPTION.
10. THIS PRODUCT MEETS EUROPEAN UNION DIRECTIVES AND OTHER
COUNTRY REGULATION AS DESCRIBED IN GS-22-008.
11. THE HOUSING WILL WITHSTAND EXPOSURE TO 260°C PEAK TEMPERATURE
FOR 15 SECONDS IN A WAVE SOLDER APPLICATION WITH A 1.5mm
MINIMUM THICK CIRCUIT BOARD. SEE APPLICATION NOTES/PROCEDURES
IF THEY ARE AVAILABLE.
12. PLATING OPTIONS:
MAY BE EITHER GOLD OR GXT PLATED AT MANUFACTURER'S OPTION.

FCI
FCIconnect.com
Copyright FCI

mat'l. code		surface	tolerance	projection	product family
-		ISO 1902	ISO 406 ISO 1101		CARD CONN.
itr	ecr no	dr	date	title	
V				GUIDE PIN CARD CONNECTOR	
		angles	linear	INCH/MM	scale 4:1
		0°±2°	.XX ±.01/.X±0.3 .XXX ±.05/.XX±0.13 .XXX ±.0020/.XXX±0.051		
dr		C.DAILY	11/18/02		sheet 2 of 6 size
engr		H.SUNDY	11/18/02		66527
chr		H.SUNDY	11/18/02		A3
appd		H.SUNDY	11/18/02		type Product Customer Drawing
sheet index	revision sheet				

PRODUCT NO. NOTE 9	NO. OF POS.	A DIM	B DIM	INSUL. PLUG	SPECIAL
66527-001		UNAVAILABLE			
-002	2X2	.100/2.54	.458/11.63	NO	
-003	2X3	.200/5.08	.558/14.17		
-004	2X4	.300/7.62	.658/16.71		
-005	2X5	.400/10.16	.758/19.25		
-006	2X6	.500/12.70	.858/21.79		
-007	2X7	.600/15.24	.958/24.33		
-008	2X8	.700/17.78	1.058/26.87		
-009	2X9	.800/20.32	1.158/29.41		
-010	2X10	.900/22.86	1.258/31.95		
-011	2X11	1.000/25.4	1.358/34.49		
-012	2X12	1.100/27.94	1.458/37.03		
-013	2X13	1.200/30.48	1.558/39.57		
-014	2X14	1.300/33.02	1.658/42.11		
-015	2X15	1.400/35.56	1.758/44.65		
-016	2X16	1.500/38.10	1.858/47.19		
-017	2X17	1.600/40.64	1.958/49.73		
-018	2X18	1.700/43.18	2.058/52.27		
-019	2X19	1.800/45.72	2.158/54.81		
-020	2X20	1.900/48.26	2.258/57.35		
-021	2X21	2.000/50.80	2.358/59.89		
-022	2X22	2.100/53.34	2.458/62.43		
-023	2X23	2.200/55.88	2.558/64.97		
-024	2X24	2.300/58.42	2.658/67.51		
-025	2X25	2.400/60.96	2.758/70.05		
-026	2X26	2.500/63.50	2.858/72.59		
-027	2X27	2.600/66.04	2.958/75.13		
-028	2X28	2.700/68.58	3.058/77.67		
-029	2X29	2.800/71.12	3.158/80.21		
-030	2X30	2.900/73.66	3.258/82.75		
-031	2X31	3.000/76.20	3.358/85.29		
-032	2X32	3.100/78.74	3.458/87.83		
-033	2X33	3.200/81.28	3.558/90.37		
-034	2X34	3.300/83.82	3.658/92.91		
-035	2X35	3.400/86.36	3.758/95.45		
-036	2X36	3.500/88.90	3.858/97.99		
-037	2X37	3.600/91.44	3.958/100.53		
-038	2X38	3.700/93.98	4.058/103.07		
-039	2X39	3.800/96.52	4.158/105.61		
66527-040	2X40	3.900/99.60	4.258/108.15	NO	

mat'l code	surface ISO 1302	tolerance ISO 406 ISO 1101	projection	product family CARD CONN.
itr	ecm no	dr	date	title GUIDE PIN CARD CONNECTOR
v				dwg no 66527
	angles	linear	scale 4:1	sheet 3 of 6 size A3
	0°±2'	C.DAILY	11/18/02	type Product Customer Drawing
	enrg	H.SUNDY	11/18/02	
	chr	H.SUNDY	11/18/02	
	appd	H.SUNDY	11/18/02	
sheet index	revision sheet			



Copyright FCI

PRODUCT NO. NOTE 9	NO. OF POS.	A DIM	B DIM	INSUL. PLUG	SPECIAL
66527-041	2X41	4.000/101.60	4.358/110.69	NO	
-042	2X42	4.100/104.14	4.458/113.23		
-043	2X43	4.200/106.68	4.558/115.77		
-044	2X44	4.300/109.22	4.658/118.31		
-045	2X45	4.400/111.76	4.758/120.85		
-046	2X46	4.500/114.30	4.858/123.39		
-047	2X47	4.600/116.84	4.958/125.93		
-048	2X48	4.700/119.38	5.058/128.47		
-049	2X49	4.800/121.92	5.158/131.01		
-050	2X50	4.900/124.46	5.258/133.55		
-051	2X51	5.000/127.00	5.358/136.09		
-052	2X52	5.100/129.54	5.458/138.63		
-053	2X53	5.200/132.08	5.558/141.17		
-054	2X54	5.300/134.62	5.658/143.71		
-055	2X55	5.400/137.16	5.758/146.25		
-056	2X56	5.500/139.70	5.858/148.79		
-057	2X57	5.600/142.24	5.958/151.33		
-058	2X58	5.700/144.78	6.058/153.87		
-059	2X59	5.800/147.32	6.158/156.41		
-060	2X60	5.900/149.86	6.258/158.95		
-061	2X61	6.000/152.40	6.358/161.49		
-062	2X62	6.100/154.94	6.458/164.03		
-063	2X63	6.200/157.48	6.558/166.57		
-064	2X64	6.300/160.02	6.658/169.11		
66527-065	2X65	6.400/162.56	6.758/171.65	NO	
066 THRU					
100					

OBSOLETE



Copyright FCI

mat'l. code	surface ISO 1302	tolerance ISO 406 ISO 1101	projection	product family CARD CONN.
itr	ecm no	dr	date	tolerances unless otherwise specified
V				angles
				linear
				0°±2°
				dr
				engr
				chr
				appd
sheet index	revision sheet			

title	GUIDE PIN CARD CONNECTOR
dwg no	66527
sheet	4 of 6
size	A3
type	Product Customer Drawing

PRODUCT NO. NOTE 9	NO. OF POS.	A DIM	B DIM	INSUL. PLUG	SPECIAL
66527-501		UNAVAILABLE			
-502	2X2	.100/2.54	.458/11.63	YES	
-503	2X3	.200/5.08	.558/14.17		
-504	2X4	.300/7.62	.658/16.71		
-505	2X5	.400/10.16	.758/19.25		
-506	2X6	.500/12.70	.858/21.79		
-507	2X7	.600/15.24	.958/24.33		
-508	2X8	.700/17.78	1.058/26.87		
-509	2X9	.800/20.32	1.158/29.41		
-510	2X10	.900/22.86	1.258/31.95		
-511	2X11	1.000/25.4	1.358/34.49		
-512	2X12	1.100/27.94	1.458/37.03		
-513	2X13	1.200/30.48	1.558/39.57		
-514	2X14	1.300/33.02	1.658/42.11		
-515	2X15	1.400/35.56	1.758/44.65		
-516	2X16	1.500/38.10	1.858/47.19		
-517	2X17	1.600/40.64	1.958/49.73		
-518	2X18	1.700/43.18	2.058/52.27		
-519	2X19	1.800/45.72	2.158/54.81		
-520	2X20	1.900/48.26	2.258/57.35		
-521	2X21	2.000/50.80	2.358/59.89		
-522	2X22	2.100/53.34	2.458/62.43		
-523	2X23	2.200/55.88	2.558/64.97		
-524	2X24	2.300/58.42	2.658/67.51		
-525	2X25	2.400/60.96	2.758/70.05		
-526	2X26	2.500/63.50	2.858/72.59		
-527	2X27	2.600/66.04	2.958/75.13		
-528	2X28	2.700/68.58	3.058/77.67		
-529	2X29	2.800/71.12	3.158/80.21		
-530	2X30	2.900/73.66	3.258/82.75		
-531	2X31	3.000/76.20	3.358/85.29		
-532	2X32	3.100/78.74	3.458/87.83		
-533	2X33	3.200/81.28	3.558/90.37		
-534	2X34	3.300/83.82	3.658/92.91		
-535	2X35	3.400/86.36	3.758/95.45		
-536	2X36	3.500/88.90	3.858/97.99		
-537	2X37	3.600/91.44	3.958/100.53		
-538	2X38	3.700/93.98	4.058/103.07		
-539	2X39	3.800/96.52	4.158/105.61		
66527-540	2X40	3.900/99.60	4.258/108.15	YES	

mat'l. code	surface ISO 1802	tolerance ISO 406 ISO 1101	projection	product family CARD CONN.
itr	ecm no	dr	date	tolerances unless otherwise specified
v				angles
				linear
				0°±2°
				dr
				enrg
				chr
				appd
sheet	revision			
index	sheet			

projection	product family
INCH/MM	CARD CONN.
scale 4:1	title
	GUIDE PIN CARD CONNECTOR
	dwg no
	66527
	sheet 5 of 6 size
	A3
	type
	Product Customer Drawing

PDM: Rev:V STATUS:Released Printed: Oct 13, 2010

PRODUCT NO. NOTE 9	NO. OF POS.	A DIM	B DIM	INSUL. PLUG	SPECIAL
66527-541	2X41	4.000/101.60	4.358/110.69	YES	
-542	2X42	4.100/104.14	4.458/113.23		
-543	2X43	4.200/106.68	4.558/115.77		
-544	2X44	4.300/109.22	4.658/118.31		
-545	2X45	4.400/111.76	4.758/120.85		
-546	2X46	4.500/114.30	4.858/123.39		
-547	2X47	4.600/116.84	4.958/125.93		
-548	2X48	4.700/119.38	5.058/128.47		
-549	2X49	4.800/121.92	5.158/131.01		
-550	2X50	4.900/124.46	5.258/133.55		
-551	2X51	5.000/127.00	5.358/136.09		
-552	2X52	5.100/129.54	5.458/138.63		
-553	2X53	5.200/132.08	5.558/141.17		
-554	2X54	5.300/134.62	5.658/143.71		
-555	2X55	5.400/137.16	5.758/146.25		
-556	2X56	5.500/139.70	5.858/148.79		
-557	2X57	5.600/142.24	5.958/151.33		
-558	2X58	5.700/144.78	6.058/153.87		
-559	2X59	5.800/147.32	6.158/156.41		
-560	2X60	5.900/149.86	6.258/158.95		
-561	2X61	6.000/152.40	6.358/161.49		
-562	2X62	6.100/154.94	6.458/164.03		
-563	2X63	6.200/157.48	6.558/166.57		
-564	2X64	6.300/160.02	6.658/169.11		
66527-565	2X65	6.400/162.56	6.758/171.65	YES	
-566 THRU					
-600					
66527-800	2X50	4.900/124.46	5.258/133.55	NO	SEE NOTE 6
-801	2X30	2.900/73.66	3.258/82.75	NO	SEE NOTE 6
-802	2X40	3.900/99.066	4.258/108.15	NO	SEE NOTE 6
66527-803	2X25	2.400/60.96	2.758/70.05	YES	SEE NOTE 6

OBSOLETE

mat'l code	surface ISO 1302	tolerance ISO 406 ISO 1101	projection	product family CARD CONN.
itr	ecr no	dr	date	tolerances unless otherwise specified
V				angles linear
				0°±2°
				dr C.DAILY 11/18/02
				enrg H.SUNDY 11/18/02
				chr H.SUNDY 11/18/02
				appd H.SUNDY 11/18/02
sheet index	revision sheet			

INCH/MM	scale 4:1	product family CARD CONN.
title GUIDE PIN CARD CONNECTOR	dwg no 66527	sheet 6 of 6 size A3
type Product Customer Drawing		