

PRODUCT NUMBER
SEE TABLE

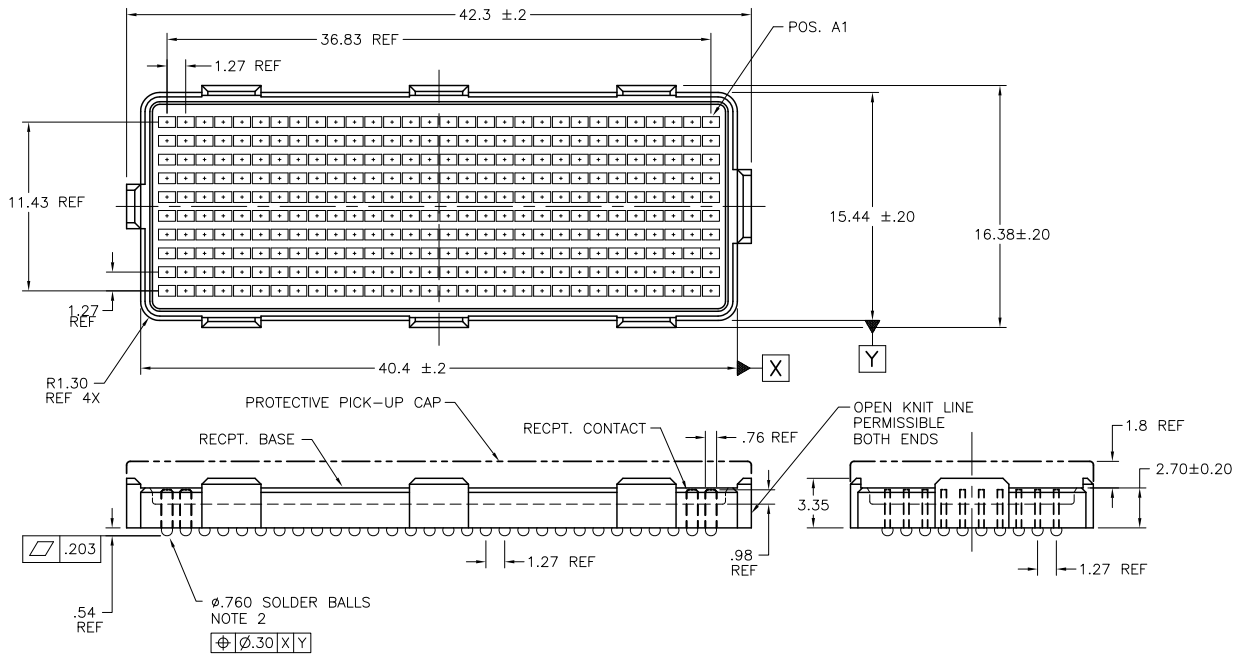

mat'l. code		surface		tolerance		projection		product family	
SEE NOTE 1		ASME Y14.5 ✓		ASME Y14.5		MM		MEG-ARRAY	
l/r	ec'n no	dr	date	tolerances unless otherwise specified		MM		title	
K	V06-0560	LP	2006-07-13	angles	X±3	MM		4mm RECEPTACLE ASSEMBLY	
L	V11-0028	HTB	2011-06-02	flatness	XX±.13	scale 3:1		10 X 30 = 300 POS.	
-	-	-	-	0° ±2'	XXX±.051	FCJ		dwg no 84501	
F	V20949	DAI	2002-08-12	dr	D. WAUGHEN	1998-12-18	sheet 1 of 3		size A4
G	V03-0680	DAI	2003-06-19	engr	D. HARPER	1998-12-18	type CUSTOMER Drawing		
H	V04-0940	VS	2004-10-18	chr	D. HARPER	1998-12-18			
J	V05-1071	DAI	2005-12-21	appd	D. HARPER	1998-12-18			
sheet	revision	L	L	L					
index	sheet	1	2	3					

PRODUCT NUMBER
SEE TABLE

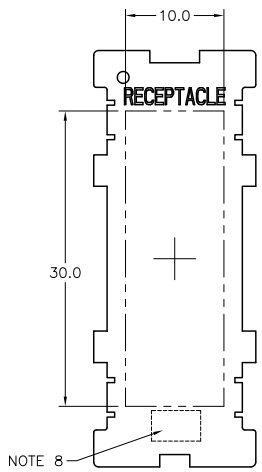

NOTE 8
FLAT AREA FOR PICK-UP CAP

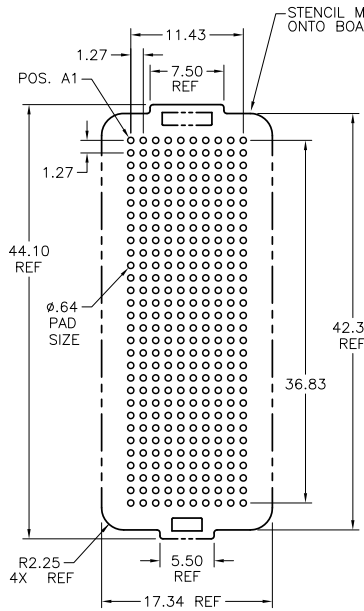

BOARD PATTERN

STENCIL MATED CONNECTOR OUTLINE
ONTO BOARD.

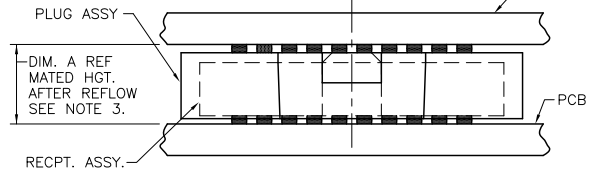

MATED HEIGHT TABLE		
DIM. A	PLUG ASSY. P/N	RECPT. ASSY. P/N
4.0	84500	84501
10.0	84578	84501

MATED HEIGHT AFTER REFLOW IS BASED ON $\phi 0.64$ mm PAD (METAL-DEFINED) AND .13mm SOLDER PASTE STENCIL THICKNESS. SEE NOTE 3.

END VIEW - MATED CONNECTORS SCALE NONE

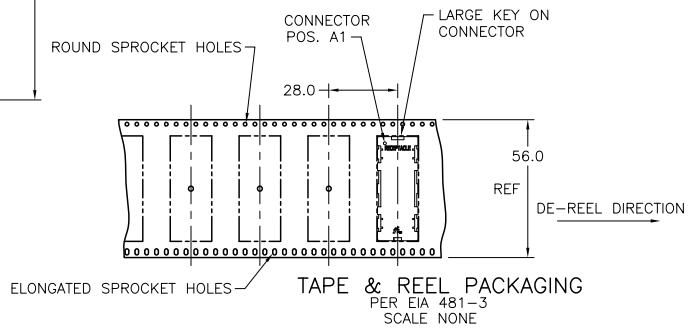

TAPE & REEL PACKAGING
PER EIA 481-3
SCALE NONE

mat'l. code	SEE NOTE 1	surface	tolerance	projection	product family
lfr	ecrn no	dr	date	ASME Y14.5 ✓ ASME Y14.5	MEG-ARRAY
				tolerances unless otherwise specified	title
				angles	4mm RECEPTACLE ASSEMBLY
				0° ±2'	10 X 30 = 300 POS.
				scale	2:1
				dr	D. WAUGHEN 1998-12-16
				engr	D. HARPER 1998-12-16
				chr	D. HARPER 1998-12-16
				appd	D. HARPER 1998-12-16
sheet	revision				
index	sheet				
					dwg no
					84501
					sheet 2 of 3
					size
					A4
					type
					CUSTOMER Drawing



PRODUCT NUMBER	PICK-UP CAP	CONTACT PLATING	SOLDER BALL	NOTES
84501-001	YES	15μ" (.38μm) Au OVER Ni	SnPb	
84501-001LF			SnAgCu LEAD FREE	5 & 6
84501-101	YES	30μ" (.76μm) Au OVER Ni	SnPb	
84501-101LF			SnAgCu LEAD FREE	5 & 6
84501-201	YES	SEE NOTE 4	SnPb	
84501-201LF			SnAgCu LEAD FREE	5 & 6
84501-A01	YES	30μ" (.76μm) Au OVER Ni NOTE 7	SnPb	
84501-A01LF			SnAgCu LEAD FREE	5 & 6

NOTES:

- ①. MATERIAL
HOUSING: LCP
CONTACT: COPPER ALLOY

PLATING
CONTACT: (SEE TABLE ON SHEET1)
SOLDER BALL: (SEE TABLE ON SHEET1)
EUTECTIC SnPb OR LEAD FREE
95.5Sn/4Ag/0.5Cu
- ②. SOLDER BALLS WILL NOT BE PERFECT SPHERICAL SHAPE DUE TO REFLOW ATTACHMENT.
- ③. MATED HEIGHT EFFECTED BY CUSTOMER'S PCB PAD SIZE, PLATING, SOLDER REFLOW PROFILE, & SOLDER PASTE.
- ④. PLATING FOR -2XX SERIES DASH NOS. MEETS THE REQUIREMENTS OF NORTEL NPS25298-2 (CENTRAL OFFICE ENVIRONMENT, 25 YEAR LIFE EXPECTANCY).
- ⑤. FOR PROPER APPLICATION FOLLOW FCI APPLICATION SPECIFICATION GS-20-033 LEAD FREE SOLDER BALLS WILL NOT SOLDER PROPERLY IN A LEADED SOLDER PROCESS DUE TO A HIGHER REFLOW TEMPERATURE. LEAD FREE PRODUCT IS THEREFORE NOT BACKWARDS COMPATIBLE WITH LEADED OR SOME SOLDERING APPLICATIONS. REFERENCE FCI APPLICATION SPECIFICATION.
- ⑥. THIS PRODUCT MEETS EUROPEAN UNION DIRECTIVES AND OTHER COUNTRY REGULATIONS AS DESCRIBED IN GS-22-008 PRODUCT MEETING THIS DIRECTIVE IS IDENTIFIED IN THE LOT CODE NUMBER MARKED ON EACH PART BY HAVING AN "X" IN THE SEVENTH CHARACTER POSITION.
- ⑦. 84501-A01 AND -A01LF ARE CUSTOMER SPECIALS.
- ⑧. CURRENT COMPANY LOGO TO BE VISIBLE IN APPROXIMATE AREA SHOWN.

mat'l code		surface		tolerance		projection		product family		
SEE NOTE 1		ASME Y14.5 ✓		ASME Y14.5				MEG-ARRAY		
ltr	ec'n no	dr	date	tolerances unless otherwise specified		MM		title		
				angles	fin	Xx3		4mm RECEPTACLE ASSEMBLY		
				0° ±2'		XXx13		10 X 30 = 300 POS.		
						XXXx051		scale 2:1		
		dr	D. WAUGHEN	1998-12-16			dwg no		sheet 3 of 3	size
		engr	D. HARPER	1998-12-16			84501		A4	
		chr	D. HARPER	1998-12-16			type		CUSTOMER Drawing	
		appd	D. HARPER	1998-12-16						
sheet index	revision sheet									