

PRODUCT NUMBER
SEE TABLE

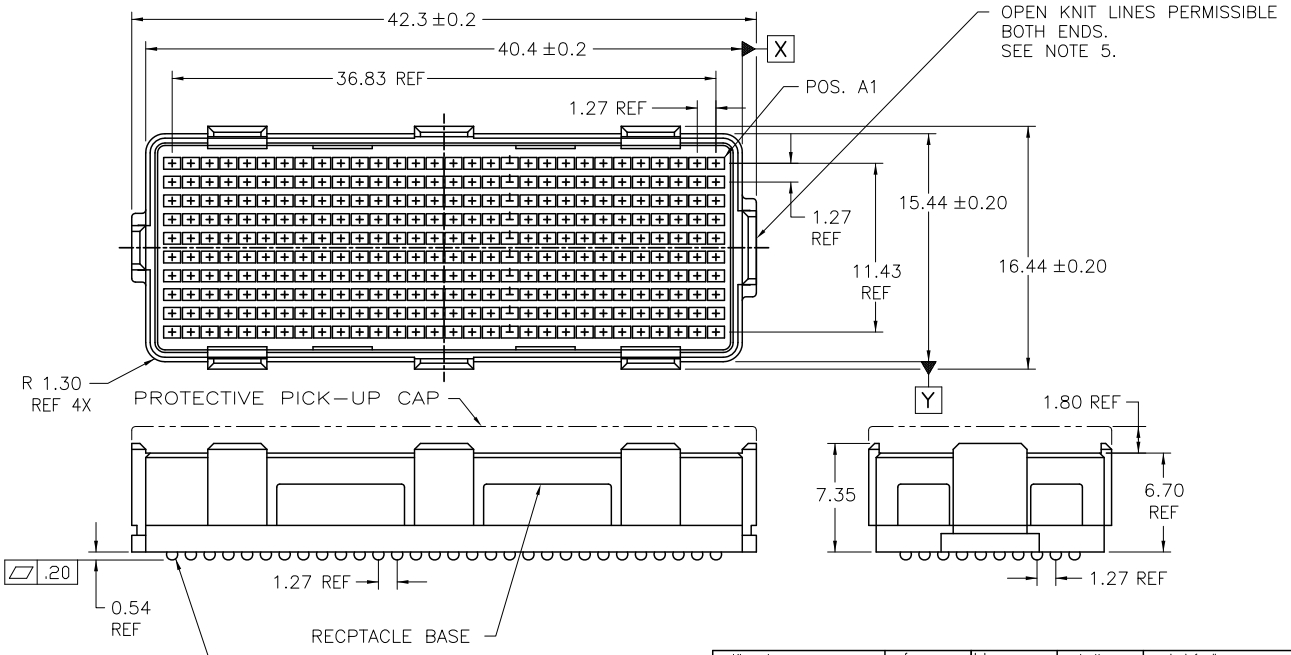

Ø 0.760 SOLDER BALLS
NOTE 2
X Y

mat'l. code	SEE NOTE 1	surface	tolerance	projection	product family
l/r	ec'n no	dr	date	ASME Y14.5 ✓ ASME Y14.5	MEG-ARRAY
A	V10246	DRW	2001-12-19	tolerances unless otherwise specified	title
B	V20932	DRW	2002-05-21	angles X = 3 XX = 13 XXX = 051	8.0mm RECEPTACLE ASSEMBLY 10 x 30 = 300 POS.
↑	V20961	↑	↑	0° ± 2'	MM
C	V03-0681	DAI	2003-06-20	dr	D. WAUGHEN
D	V04-0940	VS	2004-10-18	eng'r	W. SPINK
E	V06-0560	LP	2006-07-16	chr	W. SPINK
F	V11-0028	HTB	2011-06-02	app'd	W. SPINK
sheet	revision	F	F	F	F
index	sheet	1	2	3	4

PRODUCT NUMBER
SEE TABLE

NOTES:

- ① MATERIAL:
HOUSING: LCP
CONTACT: COPPER ALLOY

PLATING
CONTACT: (SEE TABLE ON SHEET1)
SOLDER BALL: (SEE TABLE ON SHEET1)
EUTECTIC SnPb OR LEAD FREE
95.5Sn/4Ag/0.5Cu
- ② SOLDER BALLS WILL NOT BE PERFECT SPHERICAL SHAPE DUE TO REFLOW ATTACHMENT.
- ③ MATED HEIGHT EFFECTED BY CUSTOMER'S PCB PAD SIZE, PLATING, SOLDER REFLOW PROFILE, & SOLDER PASTE.
- ④ PLATING FOR -2XX SERIES DASH NOS: Au OVER Ni WITH SPECIAL CONTACT GEOMETRY TO MEET REQUIREMENTS OF TELCORDIA GR-1217-CORE: CENTRAL OFFICE ENVIRONMENT.
- ⑤ KNIT LINE: SLIGHT VISIBLE MARKS (USUALLY A LINE) INDICATING THE DIRECTION AND MEETING POINT OF PLASTIC RESIN FLOW FRONTS TRAVELING AROUND ANY OBSTRUCTIONS TO THE RESIN FLOW VIA THE REQUIRED MOLD TOOLING.
- ⑥ FOR PROPER APPLICATION FOLLOW FCJ APPLICATION SPECIFICATION GS-20-033 LEAD FREE SOLDER BALLS WILL NOT SOLDER PROPERLY IN A LEADED SOLDER PROCESS DUE TO A HIGHER REFLOW TEMPERATURE. LEAD FREE PRODUCT IS THEREFORE NOT BACKWARDS COMPATIBLE WITH LEADED OR SOME SOLDERING APPLICATIONS. REFERENCE FCJ APPLICATION SPECIFICATION
- ⑦ THIS PRODUCT MEETS EUROPEAN UNION DIRECTIVES AND OTHER COUNTRY REGULATIONS AS DESCRIBED IN GS-22-008 PRODUCT MEETING THIS DIRECTIVE IS IDENTIFIED IN THE LOT CODE NUMBER MARKED ON EACH PART BY HAVING AN "X" IN THE SEVENTH CHARACTER POSITION.
- ⑧ 84553-A01 AND -A01LF ARE CUSTOMER SPECIALS.
- ⑨ CURRENT COMPANY LOGO TO BE VISIBLE IN APPROXIMATE AREA SHOWN.

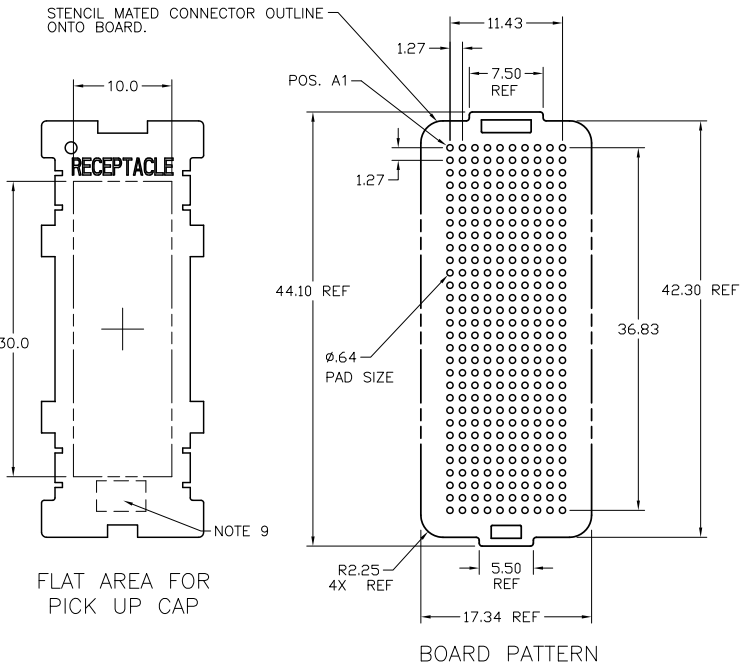

mat'l. code	SEE NOTE 1	surface	tolerance	projection	product family
lfr	ecrn no	dr	date	ASME Y14.5 ✓ ASME Y14.5	MEG-ARRAY
F				tolerances unless otherwise specified	title
				angles	8.0mm RECEPTACLE ASSEMBLY
				0° ±2'	10 x 30 = 300 POS.
				dr	sheet 2 of 4 size
				engr	84553
				chr	A4
				appd	type
sheet	revision				CUSTOMER Drawing
index	sheet				

PRODUCT NUMBER	PICK-UP CAP	CONTACT PLATING	SOLDER BALL	NOTES
84553-001	YES	15u" (.38um) Au OVER Ni	SnPb	6 & 7
84553-001LF			SnAgCu LEAD FREE	
84553-101	YES	30u" (.76um) Au OVER Ni	SnPb	6 & 7
84553-101LF			SnAgCu LEAD FREE	
84553-201	YES	SEE NOTE 4	SnPb	6 & 7
84553-201LF			SnAgCu LEAD FREE	
84553-A01	YES	30u" (.76um) Au OVER Ni NOTE 8	SnPb	6 & 7
84553-A01LF			SnAgCu LEAD FREE	

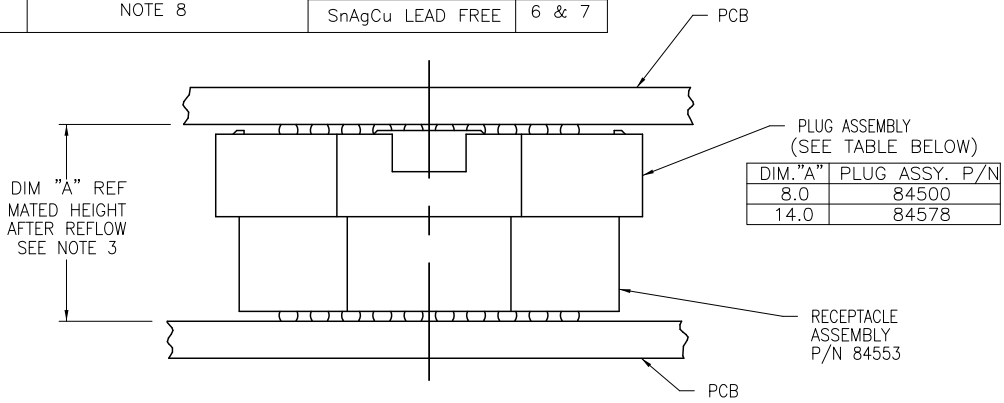

DIM. "A"	PLUG ASSY. P/N
8.0	84500
14.0	84578

MATED HEIGHT AFTER REFLOW IS BASED ON ø.64mm PAD (METAL-DEFINED) AND .13mm SOLDER PASTE STENCIL THICKNESS. SEE NOTE 3.
END VIEW - MATED CONNECTORS

mat'l. code	SEE NOTE 1	surface	tolerance	projection	product family
lfr	ecrn no	ASME Y14.5 ✓	ASME Y14.5		MEG-ARRAY
F	dr	date	tolerances unless otherwise specified	MM	title
			angles	X +3	8.0mm RECEPTACLE ASSEMBLY
			0° ±2'	XX +13	10 x 30 = 300 POS.
			xxx +051	scale 5:1	dwg no
	dr	D. WAUGHEN	2000-02-23		sheet 3 of 4 size
	engr	W. SPINK	2000-02-23		84553
	chr	W. SPINK	2000-02-23		A4
	appd	W. SPINK	2000-02-23		type
sheet index	revision sheet				CUSTOMER Drawing

PRODUCT NUMBER
SEE TABLE

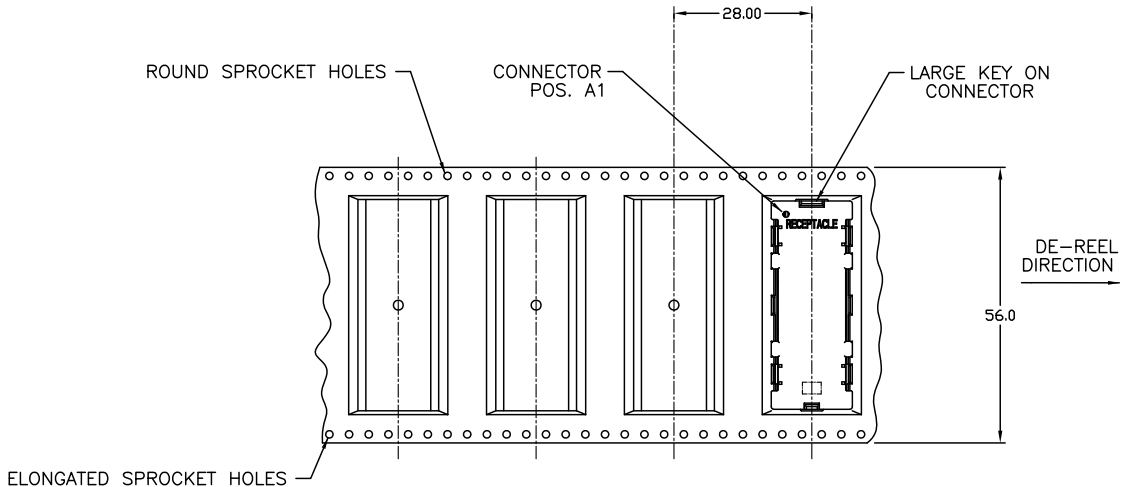

TAPE & REEL PACKAGING
PER EIA 481-3

mat'l. code		SEE NOTE 1		surface	tolerance	projection	product family
lfr	ecm no	dr	date	ASME Y14.5	ASME Y14.5		MEG-ARRAY
				tolerances unless otherwise specified		MM	title
F				angles	X +3		8.0mm RECEPTACLE ASSEMBLY
				0° ±2'	XX +1B	scale 1:1	10 x 30 = 300 POS.
					XXX +051		dwg no
				dr	D. WAUGHEN	2000-02-23	sheet 4 of 4
				engr	W. SPINK	2000-02-23	size
				chr	W. SPINK	2000-02-23	A4
				appd	W. SPINK	2000-02-23	type
sheet index	revision sheet						CUSTOMER Drawing