

PRODUCT NUMBER  
SEE SHEET 3

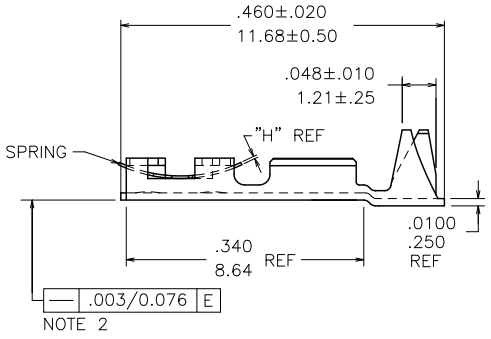
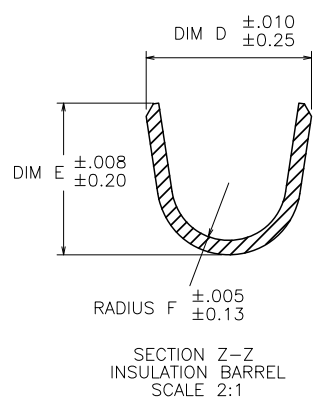
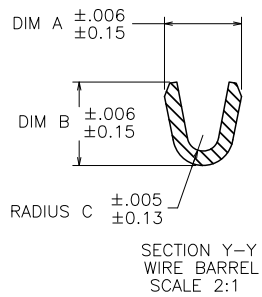
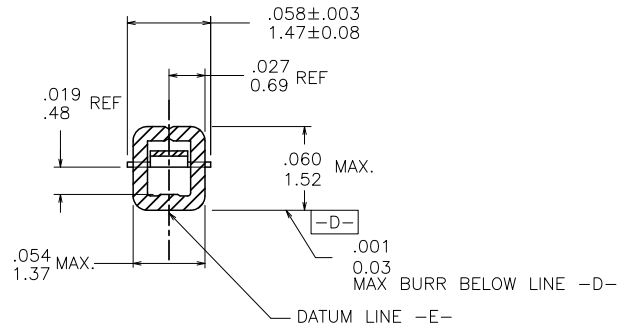
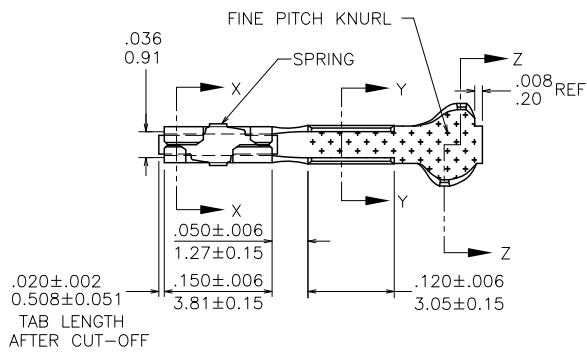

mat'l code		surface		tolerance		projection		product family	
SEE TABLE		✓		tolerances unless otherwise specified		INCH/MM		PV TERMINALS	
lir	ec'n no	dr	date	angles	linear	scale 5:1		title	
AG	v07-0218	HTB	2007-03-16					MINI PV™ RECEPTACLE	
AH	v08-0113	HTB	2008-03-26					CRIMP TO WIRE	
AJ	f08-0159	HTB	2008-04-16					dwg no	
AK	f08-0189	HTB	2008-06-25	dr	T. BREWBAKER	2006-04-18		sheet 1 of 6	
AL	v08-0510	HTB	2008-12-02	eng'r	T. BREWBAKER	2006-04-18		size	
AM	v10-0359	HTB	2010-09-16	chr	T. BREWBAKER	2006-04-18		47212	
				app'd	T. BREWBAKER	2006-04-18		A3	
sheet index	revision sheet	AM	AM	AM	AM	AM	AM	type Product Customer Drawing	
		1	2	3	4	5	6		

PRODUCT NUMBER SEE SHEET 3	WIRE BARREL			INSULATION BARREL				RECOMMENDED HANDTOOL FOR LOOSE PIECE APPLICATION	
	AWG RANGE	DIM A	DIM B	RADIUS C	INSULATION DIAMETER RANGE	DIM D	DIM E		RADIUS F
	18-20	.104/2.64	.104/2.64	.021/.53	.042/1.07-.103/2.62	.139/3.53	.120/3.05	.050/1.27	HT-0073
	22-26	.070/1.78	.070/1.78	.017/.43	.036/.91-.103/2.62	.139/3.53	.120/3.05	.050/1.27	HT-0095
	28-32	.054/1.37	.058/1.47	.011/.28	.028/.71-.054/1.37	.115/2.92	.105/2.67	.040/1.02	

NOTES:

1. TERMINAL MATES WITH  $.025 \pm .002 / 0.64 \pm 0.05$  SQUARE OR ROUND PIN.
- ② WHEN MEASURED ALONG DATUM -E- WITHIN  $.340 / 8.64$  REF DIM.
3. PRODUCT SPECIFICATION: BUS-12-067.  
APPLICATION SPECIFICATIONS:  
TA-75: TERMINAL DATA FOR USE WITH MINI LATCH HOUSING.  
TA-146: TERMINAL DATA FOR CONTACTS NOT USED IN HOUSINGS.  
TA-210: TERMINAL DATA FOR CONTACTS USED WITH MINI ROD HOUSINGS.  
TA-228: APPLICATIONS USING 20 AWG WIRE.  
TA-531: INSTALLING AND REMOVING TERMINALS.
- ④ PRODUCT MEETS EUROPEAN UNION DIRECTIVES AND OTHER COUNTRY REGULATIONS AS DESCRIBED IN GS-22-008.
5. THIS PRODUCT IS NOT INTENDED TO BE EXPOSED TO MANUFACTURING SOLDERING PROCESSES.
- ⑥ THIS PRODUCT HAS 100% TIN PLATING IN THE INTERFACE AND HAS NOT BEEN TESTED FOR WHISKER GROWTH IN ALL INTERCONNECT ENVIRONMENTS.
- ⑦ REMAINDER OF TOP OF PART TO BE GOLD FLASH OVER  $50 \mu'' / 1.27 \mu\text{m}$  NICKEL. BACKSIDE OF TERMINALS TO BE PLATED WITH  $30 \mu'' / 0.76 \mu\text{m}$  NICKEL ONLY.

mat'l code	SEE TABLE		surface	tolerance	projection	product family
tr	ecm no	dr	date	tolerances unless otherwise specified		PV TERMINALS
AM				angles	linear	INCH/MM
						scale 1:1
		dr	T. BREWBAKER	2006-04-18		title
		engr	T. BREWBAKER	2006-04-18		MINI PV™ RECEPTACLE CRIMP TO WIRE
		chr	T. BREWBAKER	2006-04-18		dwg no
		appd	T. BREWBAKER	2006-04-18		47212
sheet index	revision sheet					sheet 2 of 6
						size A3
						type Product Customer Drawing

PDM: Rev:AM STATUS: Released Printed: May 26, 2011

MATERIAL & PLATING		SPRING THICKNESS DIM H±.0005/0.012	AWG RANGE	REELED NOTE 4	LOOSE NOTE 4	PLATING AVAILABILITY									
1/4 HARD BRASS BODY	Be/Cu SPRING					-000	-000LF	-001	-001LF	-002	-002LF				
CONTACT AREA UNDERPLATING: 50µ"/1.27µ Ni CONTACT AREA: 15µ"/0.38µ Au INSIDE BOX AREA: -000LF Au FLASH -001LF 15µ"/0.38µ Au -002LF 6µ"/0.15µ Au REMAINDER: -000LF SEE NOTE 7 -001LF 15µ"/0.38µ Au -002LF Au FLASH	Au FLASH	.0035/0.089	18-20	48241	48250	NO	YES	NO	NO	NO	NO				
			22-26	48242	48251	NO	YES	NO	NO	NO	NO				
			28-32	48243	48252	NO	YES	NO	NO	NO	NO				
		.0048/0.122	Au FLASH	.0035/0.089	18-20	48244	48253	NO	YES	NO	NO	NO	NO		
					22-26	48245	48254	NO	YES	NO	NO	NO	NO		
					28-32	48246	48255	NO	YES	NO	NO	NO	NO		
		.0058/0.147	Au FLASH	.0048/0.122	18-20	94011	94014	NO	NO	NO	NO	NO	NO	OBS.	
					22-26	94012	94015	NO	NO	NO	NO	NO	NO	OBS.	
					28-32	94013	94016	NO	NO	NO	NO	NO	NO	OBS.	
		.0065/0.165	Au FLASH	.0058/0.147	18-20	48247	48256	NO	YES	NO	NO	NO	NO		
					22-26	48248	48257	NO	YES	NO	NO	NO	NO		
					28-32	48249	48258	NO	YES	NO	NO	NO	NO		
CONTACT AREA UNDERPLATING: 50µ"/1.27µ Ni CONTACT AREA: 30µ"/0.76µ Au INSIDE BOX AREA: -000LF Au FLASH -001LF 30µ"/0.76µ Au -002LF 8µ"/0.2µ Au REMAINDER: -000LF SEE NOTE 7 -001LF 30µ"/0.76µ Au -002LF Au FLASH	Au FLASH	.0035/0.089	18-20	48231	48266	NO	YES	NO	NO	NO	NO				
			22-26	48049	48235	NO	YES	NO	NO	NO	NO	YES			
			28-32	48048	48238	NO	YES	NO	NO	NO	NO	YES			
		.0048/0.122	Au FLASH	.0035/0.089	18-20	48047	48232	NO	YES	NO	NO	NO	YES		
					22-26	48046	48234	NO	YES	NO	NO	NO	NO	YES	
					28-32	48045	48237	NO	YES	NO	NO	NO	NO	YES	
		.0058/0.147	Au FLASH	.0048/0.122	18-20	94017	94019	NO	NO	NO	NO	NO	NO	OBS.	
					22-26	94018	94020	NO	NO	NO	NO	NO	NO	OBS.	
					28-32	93259	94021	NO	NO	NO	NO	NO	NO	OBS.	
		.0065/0.165	Au FLASH	.0058/0.147	18-20	48052	48233	NO	YES	NO	NO	NO	YES*		
					22-26	48051	48236	NO	YES	NO	NO	NO	YES		
					28-32	48050	48239	NO	YES	NO	NO	NO	YES		

\* LOOSE PIECE NOT AVAILABLE

mat'l code	SEE TABLE	surface	tolerance	projection	product family
tr	ecrn no	dr	date	tolerances unless otherwise specified	title
AM				angles	linear
				linear	linear
				dr	T. BREWBAKER 2006-04-18
				engr	T. BREWBAKER 2006-04-18
				chr	T. BREWBAKER 2006-04-18
				appd	T. BREWBAKER 2006-04-18
sheet index	revision sheet				

INCH/MM	scale 1:1	product family	PV TERMINALS
		title	MINI PV™ RECEPTACLE CRIMP TO WIRE
		dwg no	47212
		sheet	3 of 6
		size	A3
		type	Product Customer Drawing

MATERIAL & PLATING		SPRING THICKNESS DIM H±.0005/0.012	AWG RANGE	REELED NOTE 4	LOOSE NOTE 4	PLATING AVAILABILITY								
1/4 HARD BRASS BODY	Be/Cu SPRING					-000	-000LF	-001	-001LF	-002	-002LF			
CONTACT AREA UNDERPLATING: 50µ"/1.27µ Ni CONTACT AREA: 40µ"/1.02µ Au INSIDE BOX AREA: -000LF Au FLASH -001LF 8µ"/0.2µ Au -002LF 8µ"/0.2µ Au REMAINDER: -000LF SEE NOTE 7 -001LF 8µ"/0.2µ Au -002LF Au FLASH	Au FLASH	.0035/0.089	18-20	48276	N/A	NO	NO	NO	NO	NO	YES			
			22-26	47457	47743	NO	YES	NO	YES	NO	YES			
			28-32	47456	47742	NO	YES	NO	YES	NO	YES			
		.0048/0.122	Au FLASH	.0035/0.089	18-20	47441	47713	NO	YES	NO	YES	NO	YES	
					22-26	47439	47712	NO	YES	NO	YES	NO	YES	
					28-32	47437	47711	NO	YES	NO	YES	NO	YES	
		.0058/0.147	Au FLASH	.0048/0.122	18-20	94022	94025	NO	NO	NO	NO	NO	NO	OBS.
					22-26	94023	94026	NO	NO	NO	NO	NO	NO	OBS.
					28-32	94024	94027	NO	NO	NO	NO	NO	NO	OBS.
		.0065/0.165	Au FLASH	.0058/0.147	18-20	47566	47746	NO	YES	NO	YES	NO	YES	
					22-26	47565	47745	NO	YES	NO	YES	NO	YES	
					28-32	47564	47744	NO	YES	NO	YES	NO	YES	
DISCONTINUED				48191	48194									
DISCONTINUED				48192	48195									
DISCONTINUED				48193	48196									
CONTACT AREA UNDERPLATING: 50µ"/1.27µ Ni CONTACT AREA: 75µ"/1.91µ Au INSIDE BOX AREA: -000LF Au FLASH -001LF 75µ"/1.91µ Au -002LF 30µ"/0.76µ Au REMAINDER: -000LF SEE NOTE 7 -001LF 75µ"/1.91µ Au -002LF 15µ"/0.38µ Au	Au FLASH	.0035/0.089	18-20	47785	48014	NO	YES	NO	NO	NO	NO	OBS.		
			22-26	47784	48015	NO	NO	NO	NO	NO	NO	OBS.		
			28-32	47783	48013	NO	NO	NO	NO	NO	NO	OBS.		
		.0048/0.122	Au FLASH	.0035/0.089	18-20	47220	47707	NO	NO	NO	NO	NO	NO	OBS.
					22-26	47216	47706	NO	YES	NO	NO	NO	NO	OBS.
					28-32	47212	47705	NO	YES	NO	NO	NO	NO	OBS.
		.0058/0.147	Au FLASH	.0048/0.122	18-20	94028	94031	NO	NO	NO	NO	NO	NO	OBS.
					22-26	94029	94032	NO	NO	NO	NO	NO	NO	OBS.
					28-32	94030	94033	NO	NO	NO	NO	NO	NO	OBS.

mat'l code	SEE TABLE	surface	tolerance	projection	product family
tr	ecm no	dr	date	tolerances unless otherwise specified	title
AM				angles linear	MINI PV™ RECEPTACLE CRIMP TO WIRE
				XXX±.01/XX±.3 XXXX.005/XX±.13 XXXX-0020/XXXX001	sheet 4 of 6 size
				dr T. BREWBAKER 2006-04-18	47212 A3
				engr T. BREWBAKER 2006-04-18	type Product Customer Drawing
				chr T. BREWBAKER 2006-04-18	
				appd T. BREWBAKER 2006-04-18	
sheet index	revision sheet				

PDM: Rev:AM STATUS: Released Printed: May 26, 2011

MATERIAL & PLATING		SPRING THICKNESS DIM H±.0005/0.012	AWG RANGE	REELED NOTE 4	LOOSE NOTE 4	PLATING AVAILABILITY							
1/4 HARD BRASS BODY	Be/Cu SPRING					-000	-000LF	-001	-001LF	-002		-002LF	
PRE-PLATED: UNDERPLATING: 50μ"/1.27μ" Ni OVERPLATING: 100-200μ"/2.54-5.08μ" 60/40 TIN LEAD  "LF NOT AVAILABLE" SEE LEAD-FREE EQUIVALENTS BELOW	Sn PLATED	.0035/0.089	22-26	47445	47747	NO	NO	NO	NO	NO	OBS.		
			28-32	47446	47748	NO	NO	NO	NO	NO	OBS.		
		.0048/0.122	18-20	47221	47716	NO	NO	NO	NO	NO	OBS.		
			22-26	47217	47715	NO	NO	NO	NO	NO	OBS.		
		.0058/0.147	18-20	94034	94037	NO	NO	NO	NO	NO	OBS.		
			22-26	94035	94038	NO	NO	NO	NO	NO	OBS.		
		.0065/0.165	18-20	47648	47749	NO	NO	NO	NO	NO	OBS.		
			22-26	47649	47750	NO	NO	NO	NO	NO	OBS.		
					28-32	47650	47751	NO	NO	NO	NO	OBS.	
		PRE-PLATED: -000LF 100-160μ" 2.54-4.06μ" Sn (LEAD-FREE) NOTE 6	Sn PLATED	.0035/0.089	22-26	47445	47747	NO	YES	NO	NO	NO	
					28-32	47446	47748	NO	YES	NO	NO	NO	
.0048/0.122	18-20			47221	47716	NO	YES	NO	NO	NO			
	22-26			47217	47715	NO	YES	NO	NO	NO			
.0058/0.147	18-20			94034	94037	NO	NO	NO	NO	NO	OBS.		
	22-26			94035	94038	NO	NO	NO	NO	NO	OBS.		
.0065/0.165	18-20			47648	47749	NO	YES	NO	NO	NO			
	22-26			47649	47750	NO	YES	NO	NO	NO			
					28-32	47650	47751	NO	YES	NO	NO		

mat'l code	surface	tolerance	projection	product family
SEE TABLE	✓			PV TERMINALS
tr ecn no dr date	tolerances unless otherwise specified	angles	linear	title
AM			INCH/MM	MINI PV™ RECEPTACLE CRIMP TO WIRE
	dr T. BREWBAKER 2006-04-18	linear	scale 1:1	dwg no 47212 sheet 5 of 6 size A3
	engr T. BREWBAKER 2006-04-18			type Product Customer Drawing
	chr T. BREWBAKER 2006-04-18			
	appd T. BREWBAKER 2006-04-18			
sheet index	revision sheet			

PDM: Rev:AM STATUS: Released Printed: May 26, 2011

MATERIAL & PLATING		SPRING THICKNESS DIM H±.0005/0.012	AWG RANGE	REELED NOTE 4	LOOSE-PIECE NOTE 4			
1/4 HARD BRASS BODY	Be/Cu SPRING							
UNDERPLATING: 50u"X1.27u Ni CONTACT AREA: 30u"/0.76u CXT INSIDE BOX AREA: -600 Au FLASH REMAINDER: -600 Au FLASH	Au FLASH	.0035/0.089	18-20	48231-600	48266-600	OBS.		
			22-26	48049-600	48235-600	OBS.		
			28-32	48048-600	48238-600	OBS.		
		CONTINUED		.0048/0.122	18-20	48047-600	48232-600	OBS.
					22-26	48046-600	48234-600	OBS.
					28-32	48045-600	48237-600	OBS.
				.0058/0.147	18-20	94017-600	94019-600	OBS.
					22-26	94018-600	94020-600	OBS.
					28-32	93259-600	94021-600	OBS.
				.0065/0.165	18-20	48052-600	48233-600	OBS.
					22-26	48051-600	48236-600	OBS.
					28-32	48050-600	48239-600	OBS.



Copyright FCJ

mat'l code	SEE TABLE	surface	tolerance	projection	product family
itr	ecrn no	dr	date	tolerances unless otherwise specified	PV TERMINALS
AM				angles	linear
				linear	linear
				dr	T. BREWBAKER 2006-04-18
				engr	T. BREWBAKER 2006-04-18
				chr	T. BREWBAKER 2006-04-18
				appd	T. BREWBAKER 2006-04-18
sheet index	revision sheet				

INCH/MM	scale 1:1	FCJ
title	MINI PV™ RECEPTACLE CRIMP TO WIRE	
dwg no	47212	sheet 6 of 6 size A3
type	Product Customer Drawing	

PDM: Rev:AM STATUS: Released Printed: May 26, 2011