

PRODUCT NUMBER
SEE TABLE

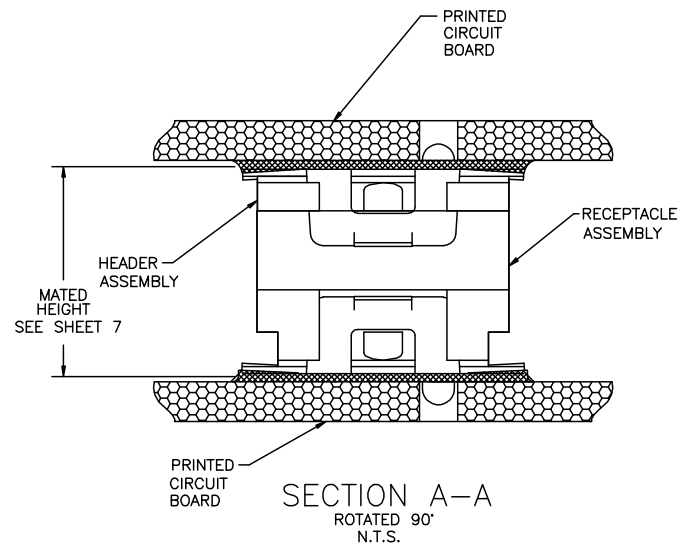

mal'l. code		surface	tolerance	projection	product family
		ISO 1902	ISO 1406 ISO 1101		CONAN
itr		tolerances unless otherwise specified		title	
ecn no	dr	date	angles	linear	INCH/MM
Y V03-1347	AA	12/20/01	XXL01/XXL03		CONAN™ CONNECTOR ASSEMBLY
AA M04-0190	MHT	9/24/04	XXXL005/XXXL013	scale 5:1	dwg no 91900 sheet 1 of 7 size A3
AB M05-0110	MHT	5/26/05	0'±2'		type Product Customer Drawing
AC M06-0232	AGS	06/12/08	dr	R.SEIPLE	11/13/91
AD M06-0373	MHT	9/26/06	eng	D.HORCHLER	01/10/92
AE M08-0012	AGS	1/11/08	chr	D.HORCHLER	01/10/92
AF M08-0287	MHT	10/02/08	appd	D.HORCHLER	01/10/92
sheet	revision	AF	AF	AF	AF
index	sheet	1	2	3	4

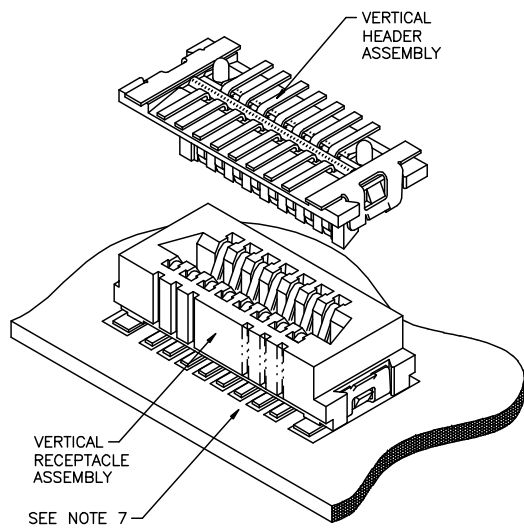
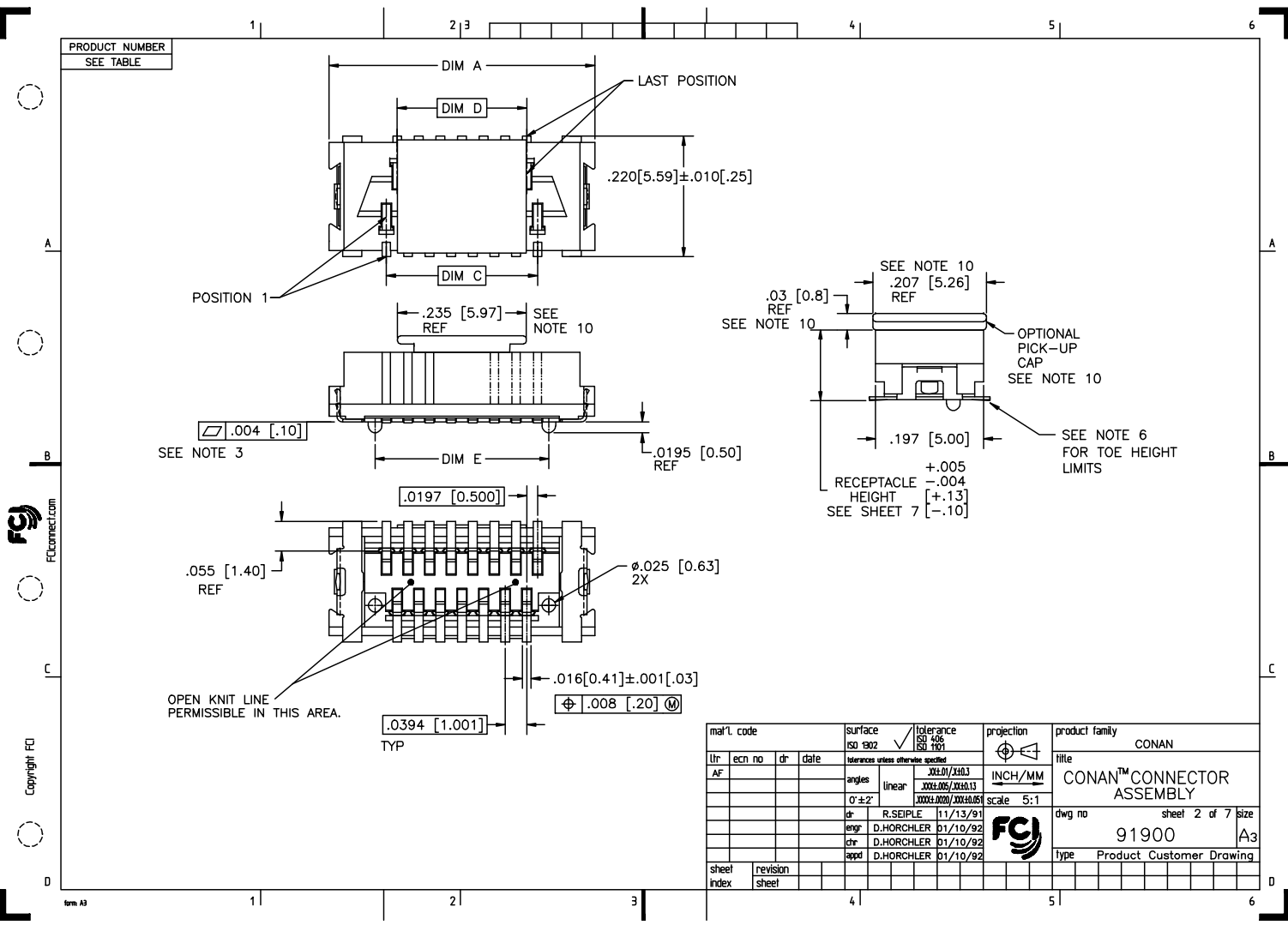

mal'l. code		surface	tolerance	projection	product family
		ISO 1902	ISO 406 ISO 1001	1st angle	CONAN
ltr	ecn no	dr	date	title	
AF				CONAN™ CONNECTOR ASSEMBLY	
angles		linear	XX±.01/XX±0.3	INCH/MM	dwg no
0°±2°			XXX±.005/XX±0.13	scale 5:1	sheet 2 of 7
			XXXX±.000/XXX±0.05		size
		dr	R.SEIPLE 11/13/91		A3
		engr	D.HORCHLER 01/10/92		
		chr	D.HORCHLER 01/10/92		
		appd	D.HORCHLER 01/10/92		
sheet index	revision sheet				type
					Product Customer Drawing

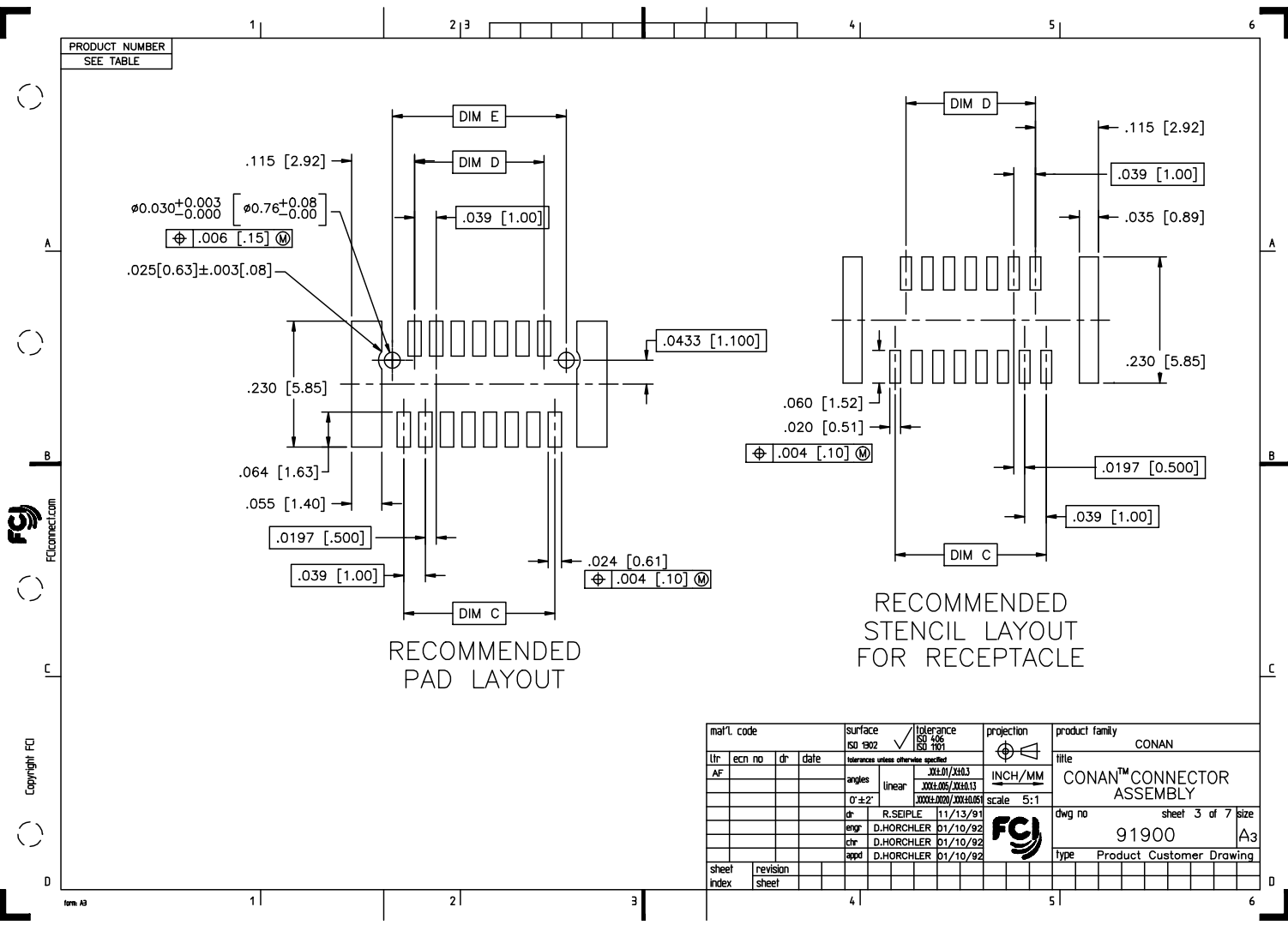

PRODUCT NUMBER
SEE TABLE

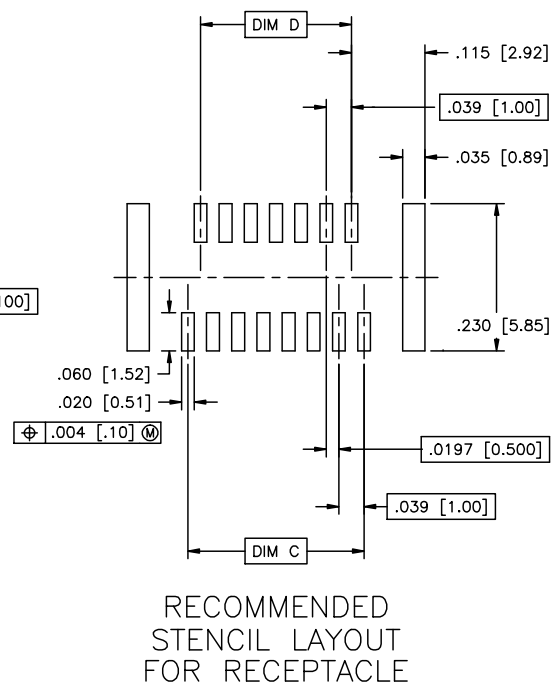
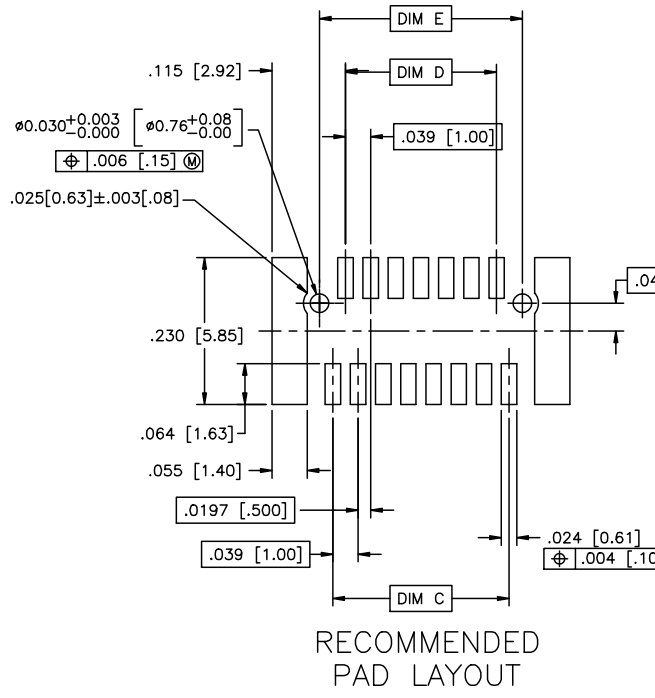

mal't. code		surface	tolerance	projection	product family
ISO 1902		ISO 1902	ISO 1436 ISO 1001	ISO 1001	CONAN
tr	ecm no	dr	date	title	
AF				CONAN™ CONNECTOR ASSEMBLY	
angles		linear	XXL01/XXL03 XXL05/XXL13 XXX±000/XXX±005	INCH/MM	dwg no
0°±2'				scale 5:1	sheet 3 of 7
dr	R.SEIPLE		11/13/91	FCJ	size
eng	D.HORCHLER		01/10/92		A3
chr	D.HORCHLER		01/10/92		91900
app	D.HORCHLER		01/10/92		type Product Customer Drawing
sheet index	revision sheet				

PRODUCT NUMBER
SEE TABLE

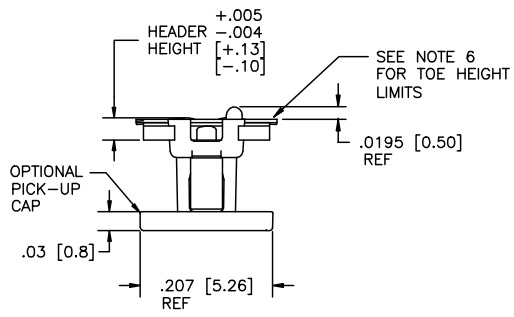
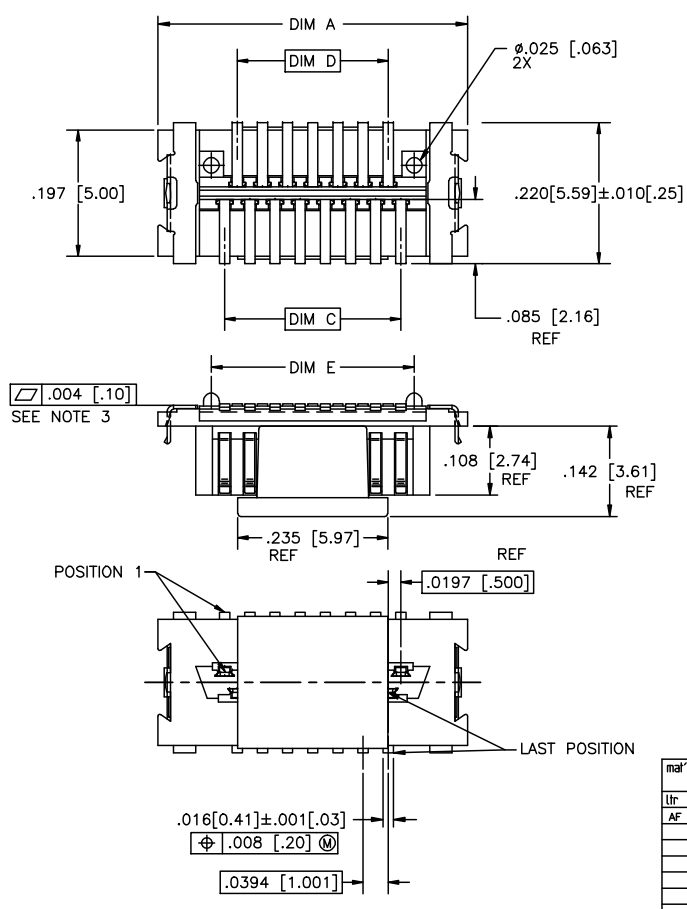

mal'l. code		surface		ISO 1902	tolerance	ISO 1436	projection	product family	
lit		ecn no	dr	date	ISO 1001		INCH/MM	CONAN	
AF		tolerances unless otherwise specified						title	
		angles		linear		scale		CONAN™ CONNECTOR ASSEMBLY	
		0°±2'		XXX±.01/XXX±0.3		5:1		dwg no	
				XXX±.005/XXX±0.13				sheet 4 of 7	
				XXX±.000/XXX±0.05				size	
								91900	
								A3	
								type	
								Product Customer Drawing	
sheet	revision								
index	sheet								

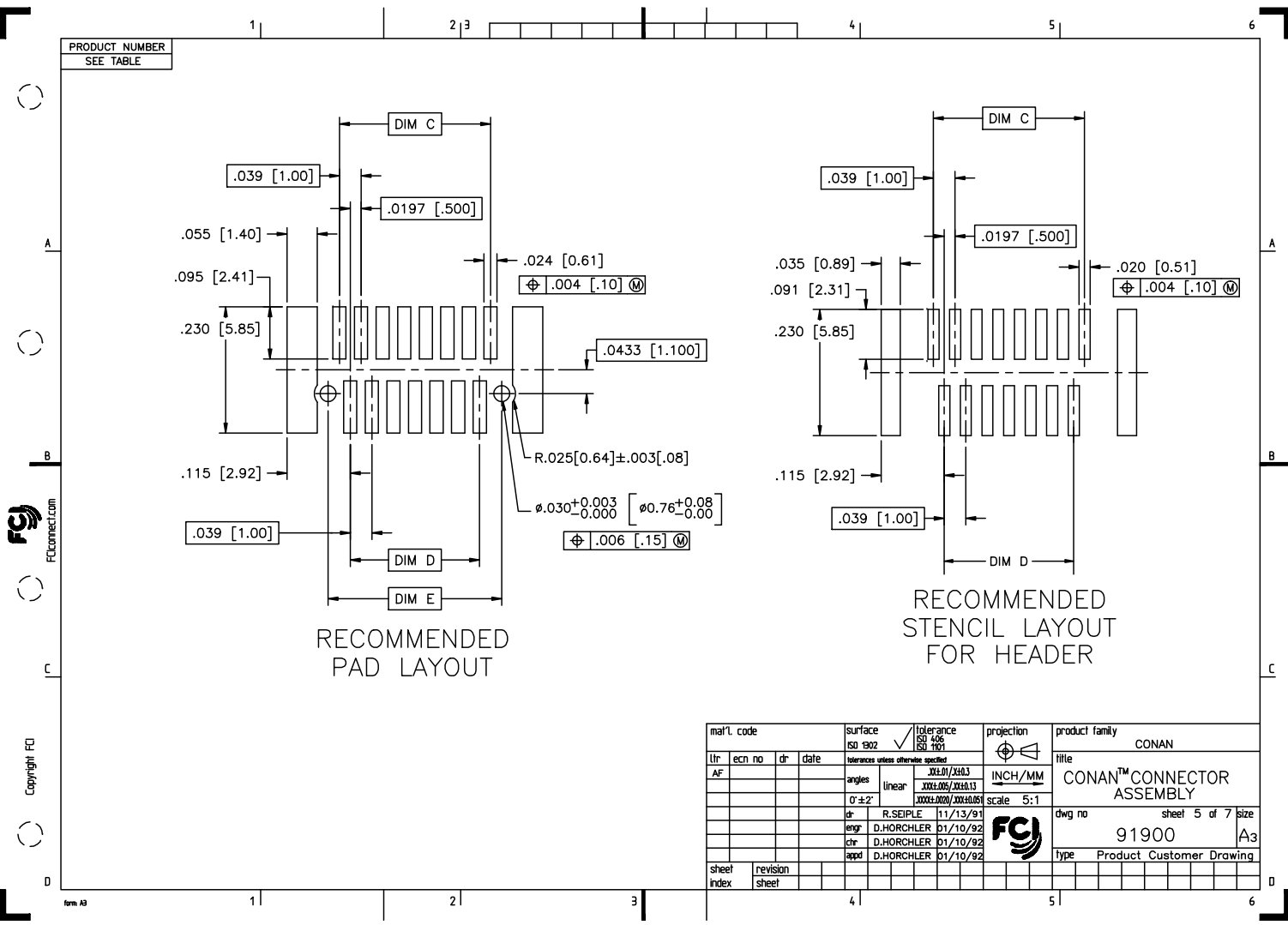

RECOMMENDED PAD LAYOUT

RECOMMENDED STENCIL LAYOUT FOR HEADER

mal't. code		surface		tolerance		projection		product family	
		ISO 1902		ISO 1436		1st angle		CONAN	
tr		ecn no		date		INCH/MM		title	
AF						5X1.01/3X0.3		CONAN™ CONNECTOR ASSEMBLY	
						XXX±.005/XXX±.13		dwg no	
						XXX±.000/XXX±0.05		91900	
						scale 5:1		sheet 5 of 7	
						FCJ		size A3	
sheet		revision		type		Product Customer Drawing			
index		sheet							

Downloaded from Elcodis.com electronic components distributor

PRODUCT NUMBER	POS	DIM "A"	DIM "C"	DIM "D"	DIM "E"
919TC-WXY09					
↑ -WXY09LF	9	.366 [9.30]	.157 [4.00]	.118 [3.00]	.1990 [5.055]
-WXY11	11	.406 [10.30]	.197 [5.00]	.157 [4.00]	.2380 [6.045]
-WXY15LF	15	.484 [12.30]	.276 [7.00]	.236 [6.00]	.3170 [8.052]
-WXY21	21	.602 [15.30]	.394 [10.00]	.354 [9.00]	.4350 [11.049]
-WXY25LF	25	.681 [17.30]	.472 [12.00]	.433 [11.00]	.5140 [13.056]
-WXY31	31	.800 [20.30]	.591 [15.00]	.551 [14.00]	.6320 [16.053]
-WXY41	41	.996 [25.30]	.787 [20.00]	.748 [19.00]	.8290 [21.057]
-WXY51LF	51	1.193 [30.30]	.984 [25.00]	.945 [24.00]	1.0260 [26.060]
-WXY69	69	1.547 [39.30]	1.339 [34.00]	1.299 [33.00]	1.3800 [35.052]
↑ -WXY69LF					

NOTES:

- MATERIALS:
 RECEPTACLE HOUSING - LCP, UL-94V-0. COLOR: NATURAL.
 RECEPTACLE TERMINALS - COPPER ALLOY, PLATED WITH 15u"/.38u GXT™ IN CONTACT AREA AND 100u"/2.54u Sn ON SOLDER LEGS WITH AN OVERALL 50u"/1.27u Ni UNDERPLATE.
 HEADER HOUSING - LCP, UL-94V-0. COLOR: NATURAL.
 HEADER TERMINALS - COPPER ALLOY, PLATED WITH 15u"/.38u GXT™ IN CONTACT AREA AND 100u"/2.54u Sn ON SOLDER LEGS WITH AN OVERALL 50u"/1.27u Ni UNDERPLATE.
 RETENTION DEVICE - BRASS, PLATED WITH 100u"/2.54u Sn OVER NICKEL.
- REFERENCE GS-12-006 FOR PRODUCT PERFORMANCE DATA.
- SEE TA-774 FOR FURTHER DESCRIPTION OF HOW THIS DIMENSION IS APPLIED.
- PICK AND PLACE CAP OR TAPE IS ONLY AVAILABLE WITH OPTION 3 PACKAGING. (PSA ADHESIVE SEALED). ALSO, PSA PACKAGING REQUIRES A PICK AND PLACE CAP.
- RECOMMENDED SOLDER PASTE THICKNESS IS .006 TO .008 INCHES THICK.
- THE TOE HEIGHT OF THE SOLDER TAIL SHALL BE MEASURED FROM THE LOWEST POINT OF THE .004 CO-PLANARITY GRAVITY PLANE. THIS MEASUREMENT IS NOT TO EXCEED A WINDOW OF .000 TO .007 INCHES.
- THREE SLOTS MAY BE LOCATED AT EITHER END OF HOUSING.
- 5.50mm MATED HEIGHT IS ONLY AVAILABLE IN 9, 15 AND 31 POS.
- 7.50mm MATED HEIGHT IS ONLY AVAILABLE IN 9 POS.
- APPLIES TO 91921-3XYZZ AND 91931-3XYZZ OPTIONS ONLY.
- THE HOUSING WILL WITHSTAND EXPOSURE TO 260°C PEAK TEMPERATURE FOR 30 SECONDS IN A CONVECTION INFRA RED OR VAPOR PHASE REFLOW OVEN. SEE APPLICATION/PROCEDURES IF THEY ARE AVAILABLE.
- PRODUCT WITH "LF" AT THE END MEETS EUROPEAN UNION DIRECTIVES AND OTHER COUNTRY REGULATION AS DESCRIBED IN GS-22-008.

mal'l. code		surface	tolerance	projection	product family
		ISO 1902	ISO 406		CONAN
		ISO 1001	ISO 1001		
lfr	ecn no	dt	date	tolerances unless otherwise specified	title
AF				linear	CONAN™ CONNECTOR ASSEMBLY
				angles	INCH/MM
				0°±2'	scale 5:1
				dt	R.SEIPLE 11/13/91
				eng	D.HORCHLER 01/10/92
				chr	D.HORCHLER 01/10/92
				appd	D.HORCHLER 01/10/92
sheet	revision				
index	sheet				

PRODUCT NUMBER
SEE TABLE

CONAN ASSEMBLY PART NUMBER

919 T C - W X Y ZZ LF

LEAD FREE OPTION
SEE NOTE 12

TYPE	T
HEADER WITH NO PEGS	0
HEADER WITH PEGS	1
RECEPTACLE WITH NO PEGS	2
RECEPTACLE WITH PEGS	3

PICK AND PLACE CAP OR TAPE (NOTE 4)	C
WITHOUT CAP OR TAPE	0
WITH CAP	1
WITH TAPE (RECEPTACLE ONLY)	2

PACKAGING	W
TUBE	2
PRESSURE SEALED TAPE & REEL	3

NOTE 4

Y	HEADER HEIGHT	RECEPTACLE HEIGHT	MATED HEIGHT	+0.10 -0.08 [+.25] [-.20]
1	.034 [.86]	.129 [3.28]	.163 [4.15]	
2	.048 [1.23]		.177 [4.50]	
3	.068 [1.73]		.197 [5.00]	
4	.107 [2.72]		.236 [6.00]	
5	.1465 [3.721]		.276 [7.00]	
6	.088 [2.23]		.216 [5.50]	
7	.1665 [4.229]		.296 [7.52]	

SEE Y=1
FOR ALL
RECEPTACLES

* NOTE 8
** NOTE 9

X	PLATING
1	15u"/.38u GXT™
2	30u"/.76u GXT™

ZZ	NUMBER OF POSITIONS
09	9
11	11
15	15
21	21
25	25
31	31
41	41
51	51
69	69

EXAMPLE: 91921-31125LF
IS A CONAN RECEPTACLE ASSEMBLY,
HAVING NO PEGS AND WITH A PICK AND PLACE CAP.
IT ALSO HAS GXT™ PLATING, IS .13 [3.2] HIGH AND 25
POSITIONS AND IS PACKAGED IN PRESSURE SEALED TAPE,
REEL AND LEAD FREE.

mal'l. code	surface ISO 1902	tolerance ISO 146 ISO 1001	projection	product family CONAN
lfr	ecn no	dr	date	title CONAN™ CONNECTOR ASSEMBLY
AF				dwg no 91900
	angles	linear	INCH/MM	sheet 7 of 7
	0'±2'	XXX±.01/XXX±.03 XXX±.005/XXX±.013 XXX±.002/XXX±.005	scale 5:1	size A3
	dr	R.SEIPLE	11/13/91	type Product Customer Drawing
	eng	D.HORCHLER	01/10/92	
	chr	D.HORCHLER	01/10/92	
	appd	D.HORCHLER	01/10/92	
sheet index	revision sheet			