

PRODUCT NUMBER
SEE TABLE

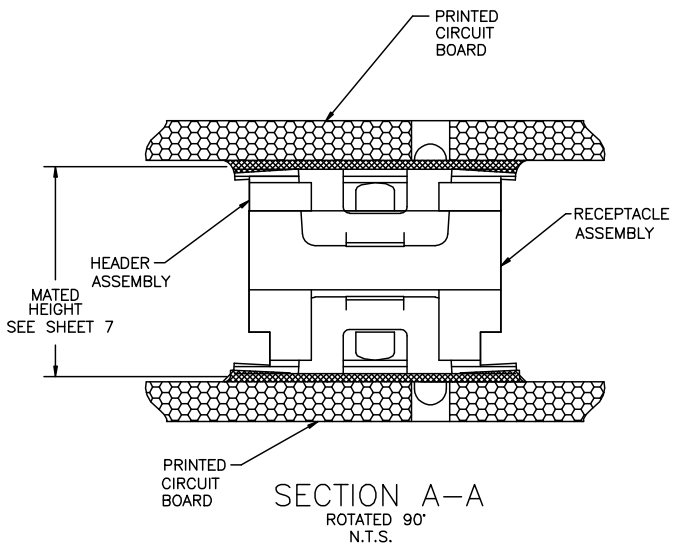

mal'l. code		surface	tolerance	projection	product family
		ISO 1902	ISO 1436 ISO 1101		CONAN
itr		tolerances unless otherwise specified		title	
ecn no	dr	date	angles	linear	INCH/MM
Y V03-1347	AA	12/20/01	XXL01/XXL03		CONAN™ CONNECTOR ASSEMBLY
AA M04-0190	MHT	9/24/04	XXXL005/XXXL013	scale 5:1	dwg no 91900 sheet 1 of 7 size A3
AB M05-0110	MHT	5/26/05	0'±2'		type Product Customer Drawing
AC M06-0232	AGS	06/12/08	dr	R.SEIPLE	11/13/91
AD M06-0373	MHT	9/26/06	eng	D.HORCHLER	01/10/92
AE M08-0012	AGS	1/11/08	chr	D.HORCHLER	01/10/92
AF M08-0287	MHT	10/02/08	appd	D.HORCHLER	01/10/92
sheet	revision	AF	AF	AF	AF
index	sheet	1	2	3	4

PRODUCT NUMBER
SEE TABLE

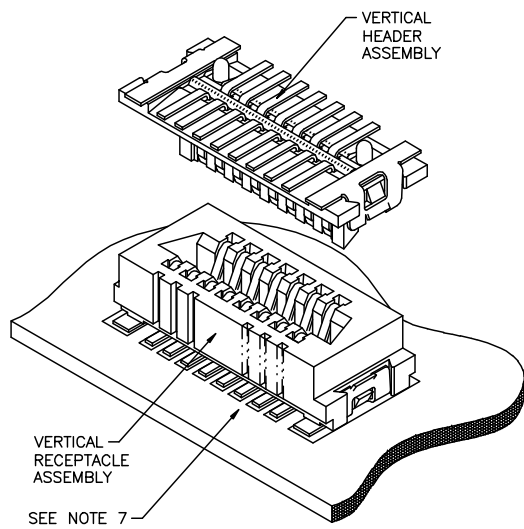
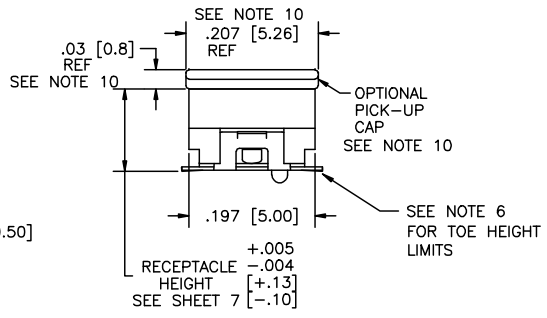
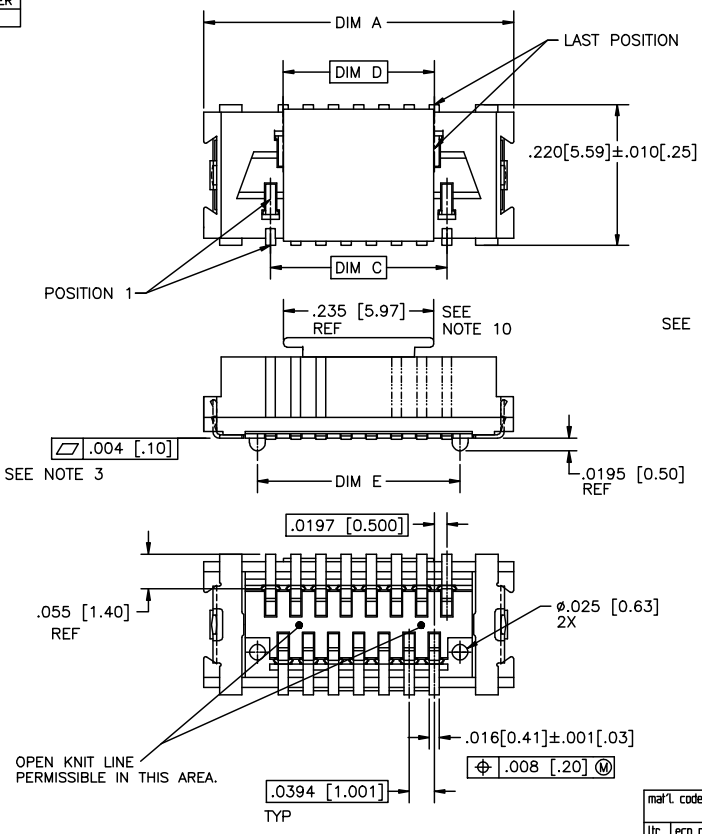

Copyright FCI

mal't. code		surface		tolerance		projection		product family	
ISO 1902		ISO 406		ISO 1001		INCH/MM		CONAN	
Intolerances unless otherwise specified		angles		linear		scale		title	
AF		0° ± 2°		.XX±.01/.XX±0.3		5:1		CONAN™ CONNECTOR ASSEMBLY	
dr		R.SEIPLE		11/13/91		FCI		dwg no	
engr		D.HORCHLER		01/10/92				sheet 2 of 7	
chr		D.HORCHLER		01/10/92				size	
appd		D.HORCHLER		01/10/92				A3	
sheet index		revision sheet						type	
								Product Customer Drawing	

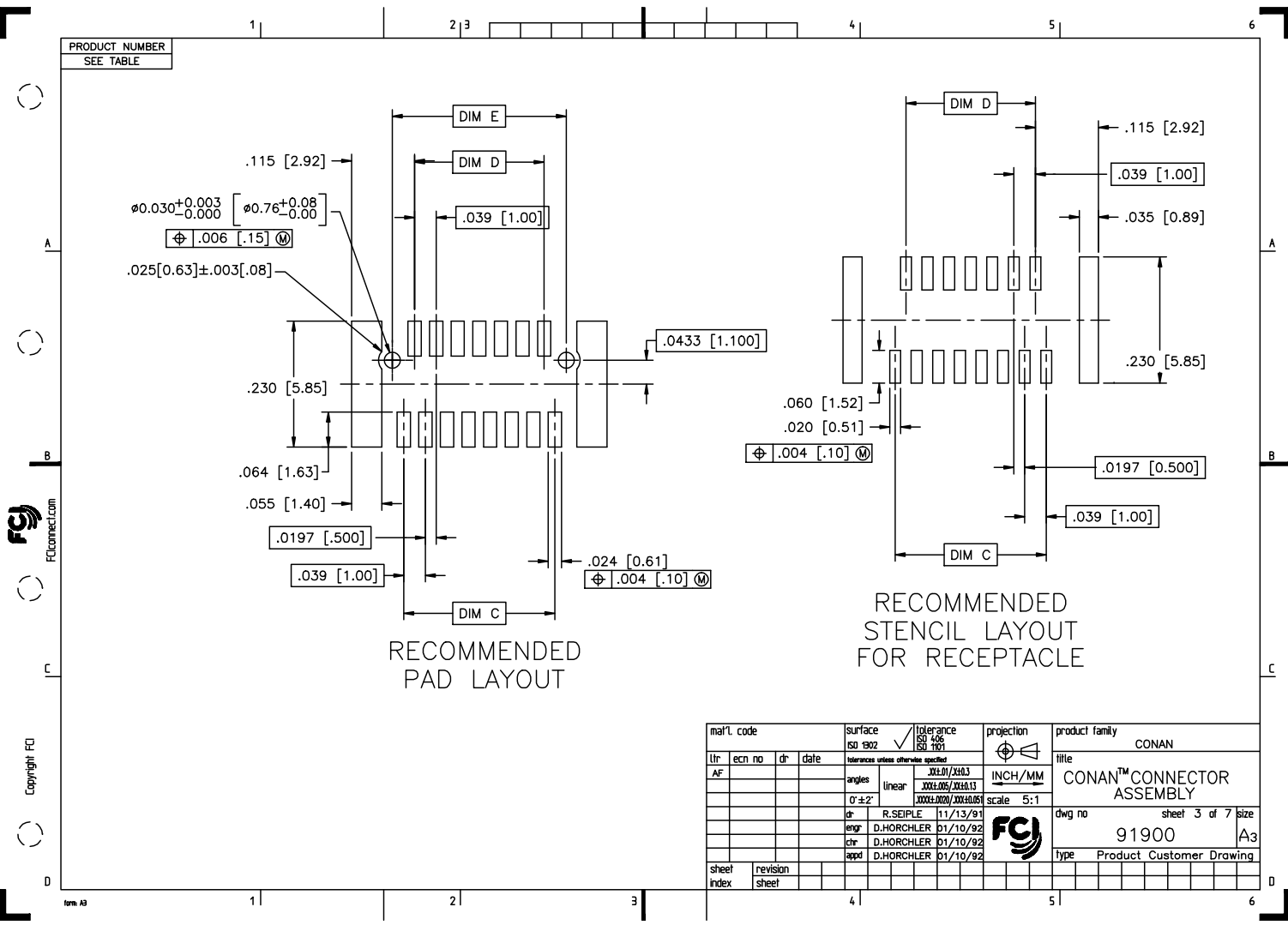

PRODUCT NUMBER
SEE TABLE

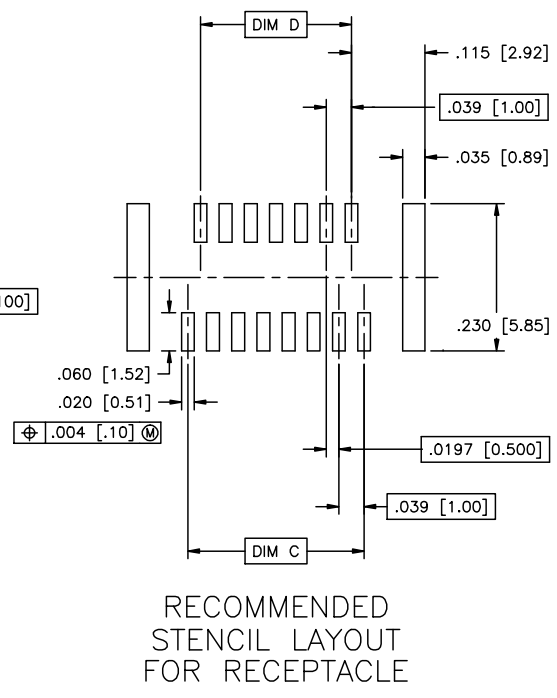
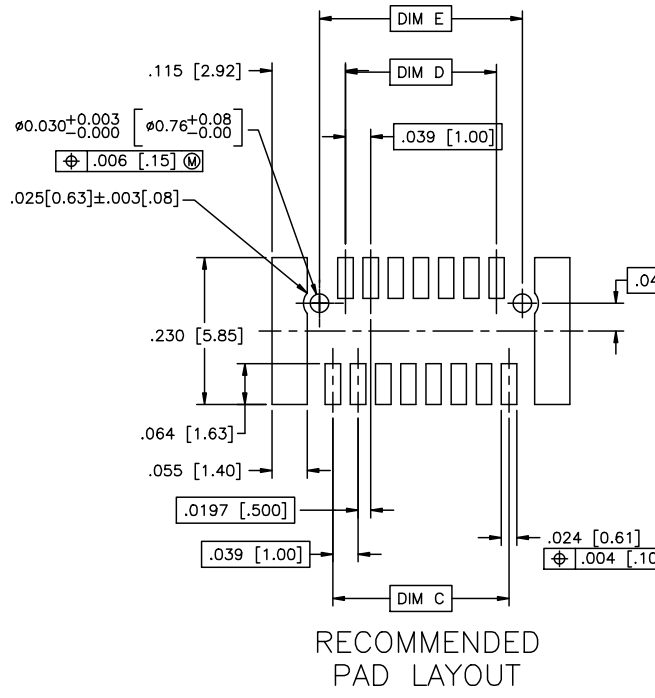

mal't. code		surface	tolerance	projection	product family
ISO 1902		ISO 1902	ISO 146	ISO 1001	CONAN
itr	ecm no	dr	date	title	
AF				CONAN™ CONNECTOR ASSEMBLY	
angles		linear	linear	INCH/MM	dwg no
0°±2'		XXX±.01/XXX±.03	XXX±.005/XXX±.013	scale 5:1	sheet 3 of 7
dr		eng	chr	app	size
R.SEIPLE 11/13/91		D.HORCHLER 01/10/92	D.HORCHLER 01/10/92	D.HORCHLER 01/10/92	A3
sheet		revision	type		
index		sheet	Product Customer Drawing		

PRODUCT NUMBER
SEE TABLE

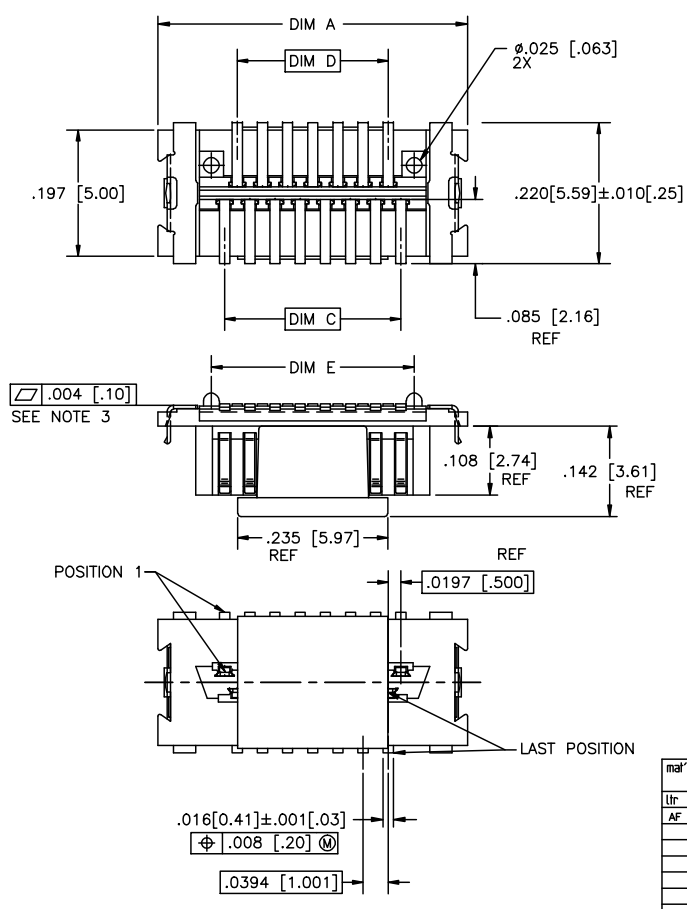

mal'l. code		surface		tolerance		projection		product family	
ISO 1902		ISO 1436		ISO 1101		INCH/MM		CONAN	
itr		ecn no		date		INCH/MM		title	
AF						5:1		CONAN™ CONNECTOR ASSEMBLY	
angles		linear		linear		scale		dwg no	
0° ± 2°		XXX±.01/XXX±0.3		XXX±.005/XXX±0.13		5:1		91900	
dr		eng		chr		appd		sheet 4 of 7	
R.SEIPLE		D.HORCHLER		D.HORCHLER		D.HORCHLER		size A3	
11/13/91		01/10/92		01/10/92		01/10/92		type Product Customer Drawing	
sheet		revision		sheet		index		6	

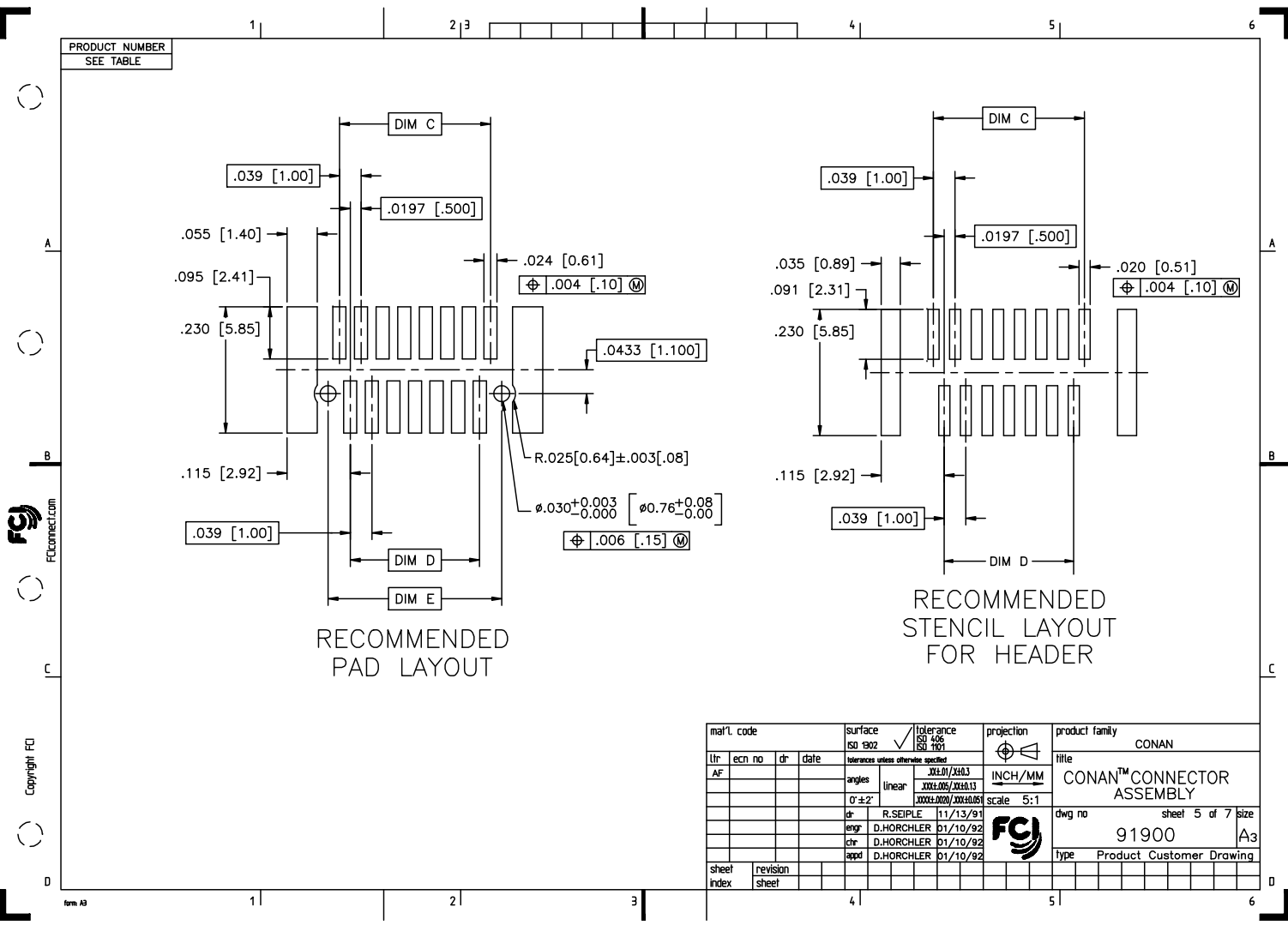

Copyright FCI

mal't. code		surface		tolerance		projection		product family	
ISO 1902		ISO 1496		ISO 1001		ASME Y14.5		CONAN	
ecn no		dr		date		INCH/MM		title	
AF						5:1		CONAN™ CONNECTOR ASSEMBLY	
angles		linear		XX±.01/XX±0.3		scale		sheet 5 of 7	
0°±2'		XXX±.005/XXX±0.13		XXX±.000/XXX±0.05		5:1		size	
dr		eng		chr		app		A3	
R.SEIPLE 11/13/91		D.HORCHLER 01/10/92		D.HORCHLER 01/10/92		D.HORCHLER 01/10/92		91900	
sheet		revision		sheet		type		Product Customer Drawing	
Index									

PRODUCT NUMBER	POS	DIM "A"	DIM "C"	DIM "D"	DIM "E"
919TC-WXY09					
↑ -WXY09LF	9	.366 [9.30]	.157 [4.00]	.118 [3.00]	.1990 [5.055]
-WXY11	11	.406 [10.30]	.197 [5.00]	.157 [4.00]	.2380 [6.045]
-WXY15LF	15	.484 [12.30]	.276 [7.00]	.236 [6.00]	.3170 [8.052]
-WXY21	21	.602 [15.30]	.394 [10.00]	.354 [9.00]	.4350 [11.049]
-WXY25LF	25	.681 [17.30]	.472 [12.00]	.433 [11.00]	.5140 [13.056]
-WXY31	31	.800 [20.30]	.591 [15.00]	.551 [14.00]	.6320 [16.053]
-WXY41	41	.996 [25.30]	.787 [20.00]	.748 [19.00]	.8290 [21.057]
-WXY51LF	51	1.193 [30.30]	.984 [25.00]	.945 [24.00]	1.0260 [26.060]
-WXY69	69	1.547 [39.30]	1.339 [34.00]	1.299 [33.00]	1.3800 [35.052]
↑ -WXY69LF					

NOTES:

1. MATERIALS:

RECEPTACLE HOUSING - LCP, UL-94V-0. COLOR: NATURAL.

RECEPTACLE TERMINALS - COPPER ALLOY, PLATED WITH 15u"/.38u GXT™ IN CONTACT AREA AND 100u"/2.54u Sn ON SOLDER LEGS WITH AN OVERALL 50u"/1.27u Ni UNDERPLATE.

HEADER HOUSING - LCP, UL-94V-0. COLOR: NATURAL.

HEADER TERMINALS - COPPER ALLOY, PLATED WITH 15u"/.38u GXT™ IN CONTACT AREA AND 100u"/2.54u Sn ON SOLDER LEGS WITH AN OVERALL 50u"/1.27u Ni UNDERPLATE.

RETENTION DEVICE - BRASS, PLATED WITH 100u"/2.54u Sn OVER NICKEL.

2. REFERENCE GS-12-006 FOR PRODUCT PERFORMANCE DATA.

③ SEE TA-774 FOR FURTHER DESCRIPTION OF HOW THIS DIMENSION IS APPLIED.

④ PICK AND PLACE CAP OR TAPE IS ONLY AVAILABLE WITH OPTION 3 PACKAGING. (PSA ADHESIVE SEALED). ALSO, PSA PACKAGING REQUIRES A PICK AND PLACE CAP.

5. RECOMMENDED SOLDER PASTE THICKNESS IS .006 TO .008 INCHES THICK.

⑥ THE TOE HEIGHT OF THE SOLDER TAIL SHALL BE MEASURED FROM THE LOWEST POINT OF THE .004 CO-PLANARITY GRAVITY PLANE. THIS MEASUREMENT IS NOT TO EXCEED A WINDOW OF .000 TO .007 INCHES.

⑦ THREE SLOTS MAY BE LOCATED AT EITHER END OF HOUSING.

⑧ 5.50mm MATED HEIGHT IS ONLY AVAILABLE IN 9, 15 AND 31 POS.

⑨ 7.50mm MATED HEIGHT IS ONLY AVAILABLE IN 9 POS.

⑩ APPLIES TO 91921-3XYZZ AND 91931-3XYZZ OPTIONS ONLY.

11. THE HOUSING WILL WITHSTAND EXPOSURE TO 260°C PEAK TEMPERATURE FOR 30 SECONDS IN A CONVECTION INFRA RED OR VAPOR PHASE REFLOW OVEN. SEE APPLICATION/PROCEDURES IF THEY ARE AVAILABLE

⑫ PRODUCT WITH "LF" AT THE END MEETS EUROPEAN UNION DIRECTIVES AND OTHER COUNTRY REGULATION AS DESCRIBED IN GS-22-008.

mal'l. code		surface		tolerance		projection		product family	
		ISO 1902		ISO 406		ISO 1001		CONAN	
lfr		ecn no		date		angles		linear	
AF						XXE.01/XXE.03		INCH/MM	
						XXE.005/XXE.13			
						XXE.000/XXE.05		scale 5:1	
		dr		R.SEIPLE		11/13/91		FCJ	
		eng		D.HORCHLER		01/10/92		dwg no	
		chr		D.HORCHLER		01/10/92		sheet 6 of 7	
		appd		D.HORCHLER		01/10/92		size	
sheet		revision						A3	
index		sheet						type	
								Product Customer Drawing	

PDM: Rev:AF

STATUS:Released

Printed: Oct 12, 2010



Copyright FCJ

PRODUCT NUMBER
SEE TABLE

CONAN ASSEMBLY PART NUMBER

919 T C - W X Y ZZ LF

LEAD FREE OPTION
SEE NOTE 12

TYPE	T
HEADER WITH NO PEGS	0
HEADER WITH PEGS	1
RECEPTACLE WITH NO PEGS	2
RECEPTACLE WITH PEGS	3

PICK AND PLACE CAP OR TAPE (NOTE 4)	C
WITHOUT CAP OR TAPE	0
WITH CAP	1
WITH TAPE (RECEPTACLE ONLY)	2

PACKAGING	W
TUBE	2
PRESSURE SEALED TAPE & REEL	3

NOTE 4

Y	HEADER HEIGHT	RECEPTACLE HEIGHT	MATED HEIGHT	+0.010 -0.008 [+.25] [-.20]
1	.034 [.86]	.129 [3.28]	.163 [4.15]	
2	.048 [1.23]		.177 [4.50]	
3	.068 [1.73]		.197 [5.00]	
4	.107 [2.72]		.236 [6.00]	
5	.1465 [3.721]		.276 [7.00]	
6	.088 [2.23]		.216 [5.50]	
7	.1665 [4.229]		.296 [7.52]	

SEE Y=1
FOR ALL
RECEPTACLES

* NOTE 8
** NOTE 9

X	PLATING
1	15u"/.38u GXT™
2	30u"/.76u GXT™

ZZ	NUMBER OF POSITIONS
09	9
11	11
15	15
21	21
25	25
31	31
41	41
51	51
69	69

EXAMPLE: 91921-31125LF
IS A CONAN RECEPTACLE ASSEMBLY,
HAVING NO PEGS AND WITH A PICK AND PLACE CAP.
IT ALSO HAS GXT™ PLATING, IS .13 [3.2] HIGH AND 25
POSITIONS AND IS PACKAGED IN PRESSURE SEALED TAPE,
REEL AND LEAD FREE.

mal'l. code		surface	tolerance	projection	product family
ISO 902		ISO 406	ISO 1001	CONAN	CONAN
itr	ecn no	dr	date	title	
AF				CONAN™ CONNECTOR ASSEMBLY	
angles		linear	XX±.01/XX±0.3	INCH/MM	
0'±2'		linear	XXX±.005/XXX±0.13	scale 5:1	
dr	R.SEIPLE	11/13/91		dwg no	
eng	D.HORCHLER	01/10/92		sheet 7 of 7	
chr	D.HORCHLER	01/10/92		size	
appd	D.HORCHLER	01/10/92		A3	
sheet	revision			type	
index	sheet			Product Customer Drawing	

PDM: Rev:AF

STATUS: Released

Printed: Oct 12, 2010