

48234-000LF - Mini-PV™,Basics+ : 2.54 mm (0.1 in.)
Centerline Crimp-to-Wire Receptacle

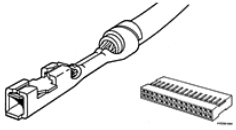

Specifications

General	
Product Type	Crimp-to-Wire Contact
Number of contacts (per housing)	10-50
Mating half	Mates with most 2.54 mm (0.1 in.) Centerline Products with 0.64 mm (0.025in.) Square or Round Pins
Dimensional	
Size (Wire)	22 to 26 AWG
Height (Crimp)	0.81 - 0.86 mm (0.032 - 0.034 in.)
Size Insulation OD (Discrete contact)	0.91 mm (0.036 in.) to 2.62 mm (0.103 in.)
Size Insulation OD (Latch housing application)	0.91 mm (0.036 in.) to 1.52 mm (0.06 in.)
Thickness (Spring)	0.122 mm (0.0048 in.)
Electrical	
Current rating	3A Continuous
Resistance (Contact)	15 M-ohms max.
Resistance (Insulation)	5000 M-ohms
Voltage rating	1000V rms
Mechanical	
Insertion force	4.41N (450 gf)
Withdrawal Force	0.75N (75 gf)
Spring force	High
Physical	
Material (Contact)	Copper Alloy
Plating (Contact area)	0.76 µm (30 µin.) Gold
Humidity Range	10% to 95%
Underplating	1.27 µm (50 µin.) Nickel
Material (Spring)	Copper Alloy
Temperature (Range)	-65°C to +125°C
Approvals / Certifications	
Approvals / Certifications	UL and CSA Approved
Other Features	
Accessory	Ratcheting Hand Crimping Tool: Part Number HT-0095
Packaging (Type)	Box
Comments	PV™ Contact Removal Tool: Part Number HT-0080

PRODUCT NUMBER
SEE SHEET 3

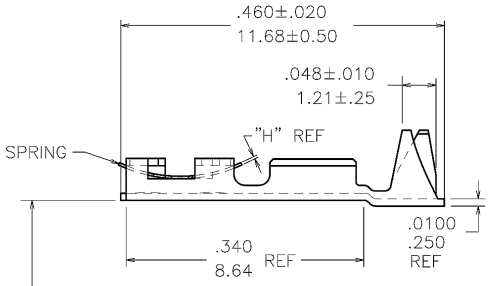
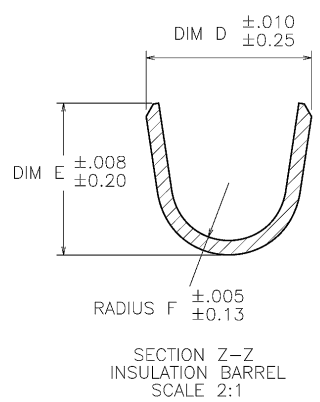
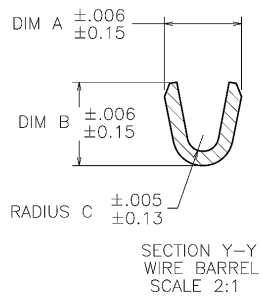
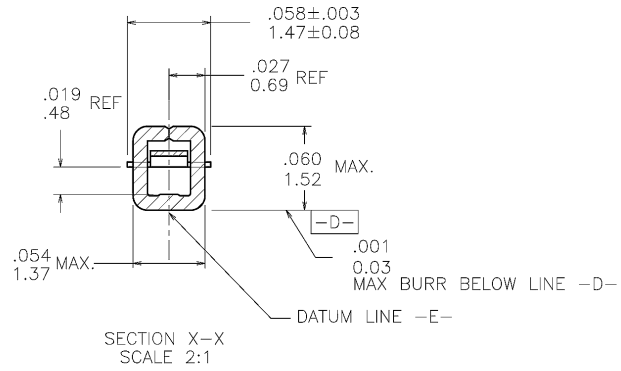
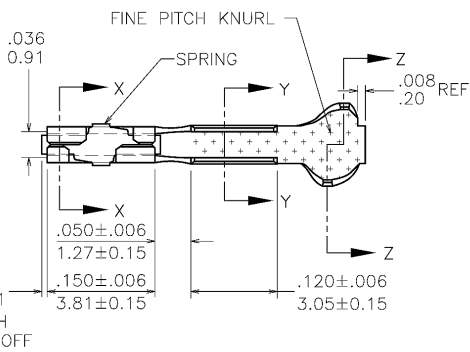

NOTE 2
 $\frac{.003}{0.076}$ E

mat'l code				surface	tolerance	projection	product family
SEE TABLE							PV TERMINALS
lir	ecn no	dr	date	tolerances unless otherwise specified		INCH/MM	title
AG	v07-0218	HTB	2007-03-16	angles	linear	scale 5:1	MINI PV™ RECEPTACLE CRIMP TO WIRE
AH	v08-0113	HTB	2008-03-26				dwg no
AJ	r08-0199	HTB	2008-04-16				sheet 1 of 6
AK	f08-0189	HTB	2008-06-25	dr	T. BREWBAKER	2006-04-18	size
				engr	T. BREWBAKER	2006-04-18	A3
AE	v06-0197	HTB	2006-03-03	chr	T. BREWBAKER	2006-04-18	47212
AF	v06-0303	HTB	2006-04-18	appd	T. BREWBAKER	2006-04-18	type
sheet	revision	AK	AK	AK	AK		Product Customer Drawing
index	sheet	1	2	3	4	5	

PDM: Rev:AK STATUS Released

PRODUCT NUMBER SEE SHEET 3	WIRE BARREL			INSULATION BARREL				
	AWG RANGE	DIM A	DIM B	RADIUS C	INSULATION DIAMETER RANGE	DIM D	DIM E	RADIUS F
	18-20	.104/2.64	.104/2.64	.021/.53	.042/1.07-.103/2.62	.139/3.53	.120/3.05	.050/1.27
	22-26	.070/1.78	.070/1.78	.017/.43	.036/.91-.103/2.62	.139/3.53	.120/3.05	.050/1.27
	28-32	.054/1.37	.058/1.47	.011/.28	.028/.71-.054/1.37	.115/2.92	.105/2.67	.040/1.02

NOTES:

1. TERMINAL MATES WITH $.025 \pm .002 / 0.64 \pm 0.05$ SQUARE OR ROUND PIN.
- ② WHEN MEASURED ALONG DATUM -E- WITHIN $.340 / 8.64$ REF DIM.
3. PRODUCT SPECIFICATION: BUS-12-067.
APPLICATION SPECIFICATIONS:
 TA-75: TERMINAL DATA FOR USE WITH MINI LATCH HOUSING.
 TA-146: TERMINAL DATA FOR CONTACTS NOT USED IN HOUSINGS.
 TA-210: TERMINAL DATA FOR CONTACTS USED WITH MINI ROD HOUSINGS.
 TA-228: APPLICATIONS USING 20 AWG WIRE.
 TA-531: INSTALLING AND REMOVING TERMINALS.
- ④ PRODUCT MEETS EUROPEAN UNION DIRECTIVES AND OTHER COUNTRY REGULATIONS AS DESCRIBED IN GS-22-008.
5. THIS PRODUCT IS NOT INTENDED TO BE EXPOSED TO MANUFACTURING SOLDERING PROCESSES.
- ⑥ THIS PRODUCT HAS 100% TIN PLATING IN THE INTERFACE AND HAS NOT BEEN TESTED FOR WHISKER GROWTH IN ALL INTERCONNECT ENVIRONMENTS.

mat'l code	SEE TABLE	surface	tolerance	projection	product family
dir	ecm no	dr	date	tolerances unless otherwise specified	title
AK				angles	MINI PV™ RECEPTACLE
				linear	CRIMP TO WIRE
				dr T. BREWBAKER 2006-04-18	dwg no
				engr T. BREWBAKER 2006-04-18	sheet 2 of 6
				chr T. BREWBAKER 2006-04-18	size
				appd T. BREWBAKER 2006-04-18	47212
sheet index	revision sheet			scale 1:1	A3
				type	Product Customer Drawing

PDM: Rev:AK STATUS Released

MATERIAL & PLATING		SPRING THICKNESS DIM H±.0005/0.012	AWG RANGE	REELED NOTE 4	LOOSE NOTE 4	PLATING AVAILABILITY							
1/4 HARD BRASS BODY	Be/Cu SPRING					-000	-000LF	-001	-001LF	-002	-002LF		
UNDERPLATING: 50μ"/1.27μ Ni CONTACT AREA: 15μ"/0.38μ Au INSIDE BOX AREA: -000LF Au FLASH -001LF 15μ"/0.38μ Au -002LF 6μ"/0.15μ Au REMAINDER: -000LF Au FLASH -001LF 15μ"/0.38μ Au -002LF Au FLASH	Au FLASH	.0035/0.089	18-20	48241	48250	NO	YES	NO	NO	NO	NO		
			22-26	48242	48251	NO	YES	NO	NO	NO	NO		
			28-32	48243	48252	NO	YES	NO	NO	NO	NO		
		.0048/0.122	18-20	48244	48253	NO	YES	NO	NO	NO	NO		
			22-26	48245	48254	NO	YES	NO	NO	NO	NO		
			28-32	48246	48255	NO	YES	NO	NO	NO	NO		
		.0058/0.147	18-20	94011	94014	NO	NO	NO	NO	NO	NO	OBS.	
			22-26	94012	94015	NO	NO	NO	NO	NO	NO	OBS.	
			28-32	94013	94016	NO	NO	NO	NO	NO	NO	OBS.	
		.0065/0.165	18-20	48247	48256	NO	YES	NO	NO	NO	NO		
			22-26	48248	48257	NO	YES	NO	NO	NO	NO		
			28-32	48249	48258	NO	YES	NO	NO	NO	NO		
UNDERPLATING: 50μ"/1.27μ Ni CONTACT AREA: 30μ"/0.76μ Au INSIDE BOX AREA: -000LF Au FLASH -001LF 30μ"/0.76μ Au -002LF 8μ"/0.2μ Au REMAINDER: -000LF Au FLASH -001LF 30μ"/0.76μ Au -002LF Au FLASH	Au FLASH	.0035/0.089	18-20	48231	48266	NO	YES	NO	NO	NO	NO		
			22-26	48049	48235	NO	YES	NO	NO	NO	NO	YES	
			28-32	48048	48238	NO	YES	NO	NO	NO	NO	YES	
		.0048/0.122	18-20	48047	48232	NO	YES	NO	NO	NO	NO	YES	
			22-26	48046	48234	NO	YES	NO	NO	NO	NO	YES	
			28-32	48045	48237	NO	YES	NO	NO	NO	NO	YES	
		.0058/0.147	18-20	94017	94019	NO	NO	NO	NO	NO	NO	NO	OBS.
			22-26	94018	94020	NO	NO	NO	NO	NO	NO	NO	OBS.
			28-32	93259	94021	NO	NO	NO	NO	NO	NO	NO	OBS.
		.0065/0.165	18-20	48052	48233	NO	YES	NO	NO	NO	NO	YES*	
			22-26	48051	48236	NO	YES	NO	NO	NO	NO	YES	
			28-32	48050	48239	NO	YES	NO	NO	NO	NO	YES	

* LOOSE PIECE NOT AVAILABLE

mat'l code	SEE TABLE	surface	tolerance	projection	product family
dir	ecrn no	dr	date	tolerances unless otherwise specified	title
AK				angles linear	MINI PV™ RECEPTACLE CRIMP TO WIRE
				dr T. BREWBAKER 2006-04-18	dwg no 47212 sheet 3 of 6 size A3
				engr T. BREWBAKER 2006-04-18	type Product Customer Drawing
				chr T. BREWBAKER 2006-04-18	
				appd T. BREWBAKER 2006-04-18	
sheet index	revision sheet				