

# PX0587, PX0588, PX0597 & PX0587/SE Wiring Instructions

Before using the connector, it is important that these instructions are carefully read and understood to ensure the connector is electrically safe. IF IN DOUBT CONSULT A QUALIFIED ELECTRICIAN.

## PX0587, PX0588, PX0597 and PX0587/SE Wiring Instructions

- 1 Remove cover.
- 2 Strip and prepare cable.

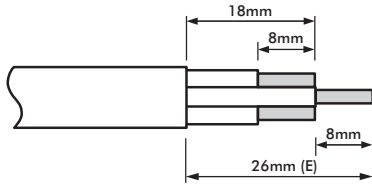

PX0587, PX0588 and PX0597

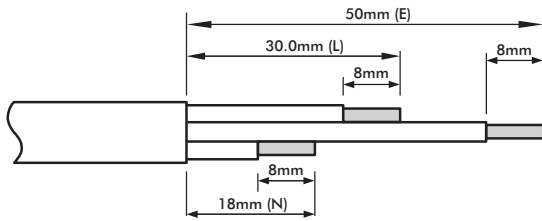

PX0587/SE

- 3 Thread cable sleeve along cable.
- 4 Connect wires to correct terminals:

Colour	European	Nth American
Live/Line (L)	Brown	Black
Neutral (N)	Blue	White
Earth/Ground (⏏)	Green/Yellow	Green

- 5 Fit cable sleeve flange into slot adjacent to cable clamp.
- 6 Tighten cable clamp ensuring cable sheath is beyond cable clamp. Reverse clamp to suit cable diameter.
- 7 Fit cover and tighten screw.

## Recommended Cable types

	Cable Construction	Typical Cable Types
European:	10A - 3 x 1.0mm <sup>2</sup>	H05VV-F, H05RR-F, H07RN-F
Nth American:	10A - 3 x 16AWG	SJT, SVT

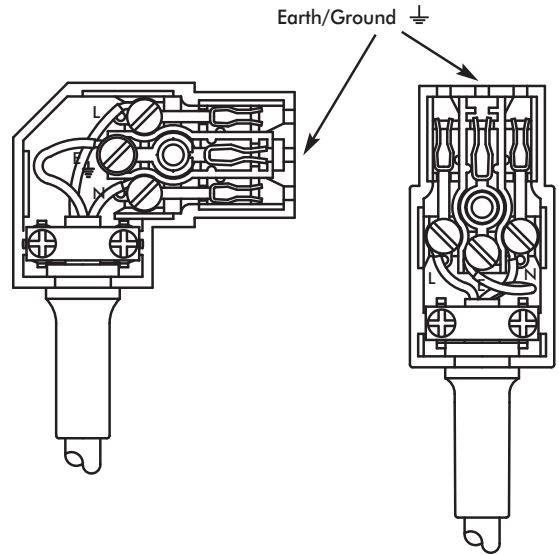

PX0587/SE

PX0587 and PX0597

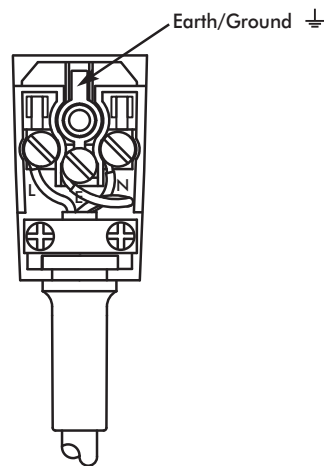

PX0588