

7334L2622F05LF

Catalogue Part Number Key

Lead Free Version (Optional)

Durability
 0: 2500 Mating Cycles
 2: 10000 Mating Cycles
 5: 100000 Mating Cycles

Number of contacts :
 2: 8 contacts ISO
 3: 16 contacts ISO + AFNOR

GENERAL:
 This L26 connector uses a "sliding" contact technology suitable for most applications.
 It has been designed for easy mounting on the PCB.

ELECTRICAL PROPERTIES:
 Insulation resistance : 5000 MΩ min
 Dielectric withstanding : 750 Vrms min
 Current carrying capacity : 10µA min, 1A max
 Contact resistance : 100mΩ max
 Card sensor type : Normally closed

MECHANICAL PROPERTIES:
 Contact Normal force : 0.6 N max (EMV Standard)
 Insertion force : 10 N max
 Extraction force : 1 N min

MATERIAL:
 Housing : Thermoplastic, Colour Black, Rated UL94V0
 Contacts and switch : Copper Alloy
 Plating : Gold over Nickel on contact area
 Matte Tin over Nickel on solder tails
 Bare edge allowed

ENVIRONMENT:
 Operating temperature: -20°C / +70°C
 Storage temperature: -40°C / +85°C
 Printed Circuit Board thickness : 1.6mm

REFERENCE DOCUMENTS:
 Product specification VGN 11596
 Packaging Specification VGN 11619

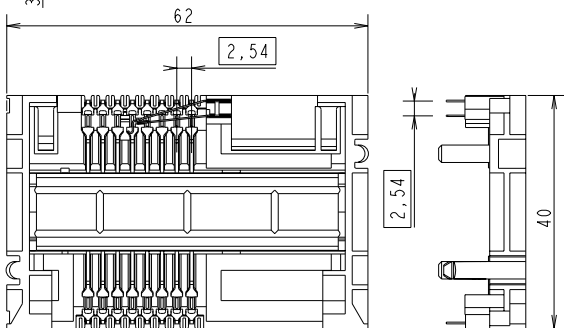
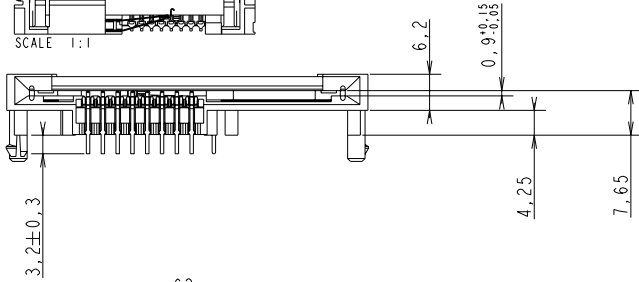
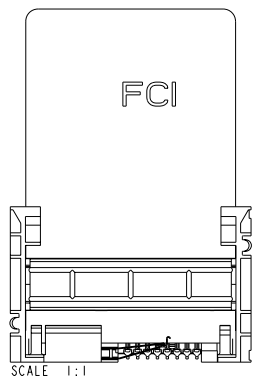

LEAD FREE VERSION:

"This product meets European Union Directives and other country regulations as described in GS-22-008"

The housing will withstand exposure to 260°C peak temperature for 10seconds in a wave solder application with a 1.6mm minimum thick circuit board. Use protective adhesive tape (Kapton or Teflon) or protective metallic devices on the areas which are directly exposed to wave soldering as it is used in classical leaded wave soldering

General Tolerances: ± 0.2 mm

lfr	ecn no	dr	date
A	F20307	DLE	2002/04/30
B	LS 3053	JTA	2003/05/13
C	105-0071	DTK	2005/06/25
D	106-0084	SSC	2006/06/21
E	106-0189	SSC	2006/10/17
F	109-0057	SSC	2009/04/15

www.fciconnect.com		surface	tolerance std	projection	mm
		ISO 1302	ISO 406 ISO 1101	mm	
		TOLERANCES UNLESS OTHERWISE SPECIFIED			
Dr	N. TWINCY	2002/04/30	ANGULAR	size	Scale
Eng	F TISSERAND	2002/04/30	LINEAR	A3	3:2
Chr	RAMESH P.K	2009/04/15	0° ±°	ECN	109-0057
Appr	S.S.CHERIAN	2009/04/15	Product family	SMART CARDS	Spec ref
					SEE NOTES
FCI		title		dwg no	Rev.
		L26 TYPE F05		VJW_54705	F
		catalog no		SEE TABLE	sheet 1 of 2

REV F - 2009-04-15

Copyright FCI

RECOMMENDED PCB LAYOUT CONTACT CONFIGURATION : ISO & AFNOR
(CONNECTOR SIDE)

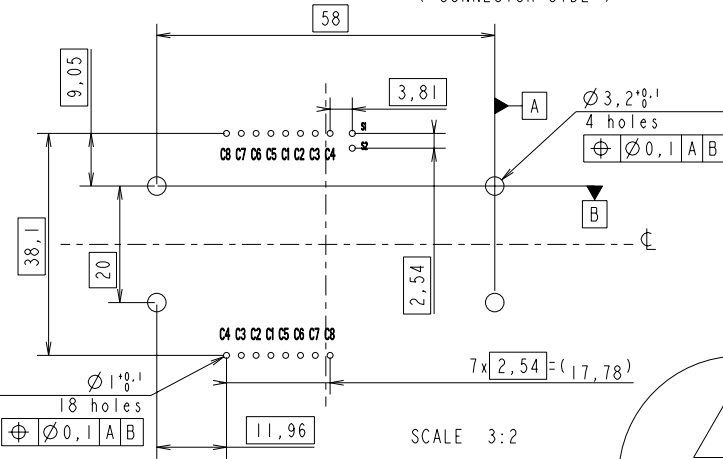

SCALE 3:2

STANDARD LAYOUT FOR 'KEEP OUT ZONE' (Connector Side)

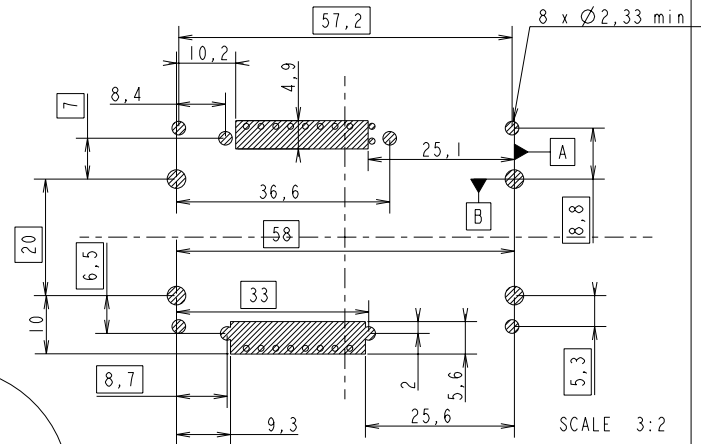

Hatching area might be free of components
Maximum free space outside of these zones = 4.25 mm

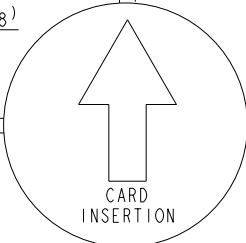

RECOMMENDED PCB LAYOUT CONTACT CONFIGURATION : ISO
(CONNECTOR SIDE)

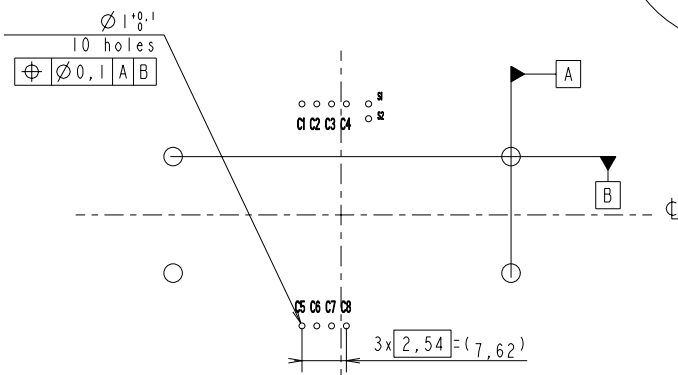

SCALE 3:2

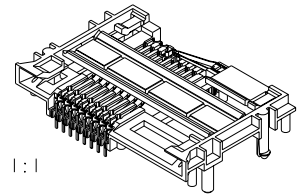

ECHELLE 1:1

EUROPEAN PROJECTION

www.fciconnect.com		surface ISO 1302	tolerance std ISO 406 ISO 1101	projection mm
		TOLERANCES UNLESS OTHERWISE SPECIFIED		
Dr	N. TWINCY	2002/04/30	ANGULAR	size A3
Eng	F. TISSERAND	2002/04/30	LINEAR	Scale 3:2
Chr	RAMESH. P. K.	2009/04/15	0° ±°	ECN 109-0057
Appr	S.S. CHERIAN	2009/04/15	Product family	Spec ref SEE NOTES
FCI		title L26 TYPE F05		dwg no VJW_54705
-		-		Rev. F
-		catalog no SEE TABLE		sheet 2 of 2