

PRODUCT NO.	INSULATOR	THERMOCOMPRESSION TAPE
10030573-100LF	NO	NO
10030573-110LF	YES	NO
10030573-200LF	NO	NO
10030573-201LF	NO	YES
10030573-210LF	YES	NO
10030573-300LF	NO	NO
10030573-310LF	YES	NO

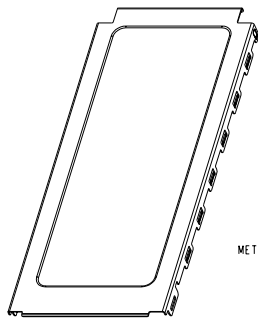

10030573-1X0LF

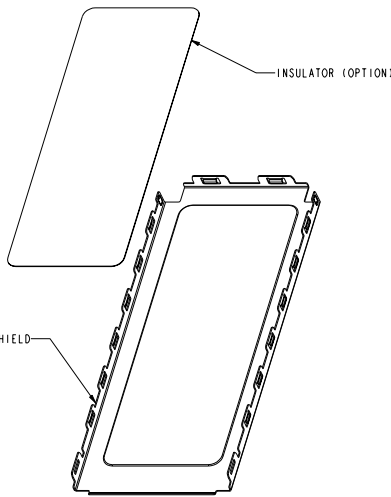

10030573-2X0LF

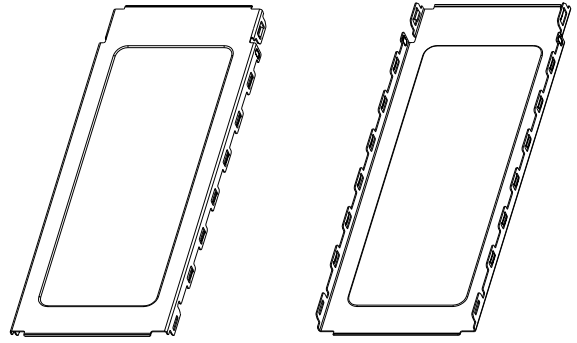

10030573-3X0LF

NOTES:
 1. MATERIAL PROPERTIES:
 METAL SHIELD : STAINLESS STEEL, SURFACE FINISH : MATTE.
 INSULATOR : POLYESTER FILM WITH ADHESIVE, 3M 1350 OR EQUIVALENT.
 2. PART NUMBER SCHEME:

10030573- X X X L F

0: WITHOUT THERMOCOMPRESSION TAPE
 1: WITH THERMOCOMPRESSION TAPE

INSULATOR
 0: NO
 1: STANDARD

SHIELD TYPE NO.
 1: STANDARD (CLOSE-END)
 2: EXTENDED (OPEN-END)

3. PRODUCT PERFORMANCE PER SPEC. GS-12-292.
 4. PACKAGING SPEC. PER GS-14-927.
 5. THIS PRODUCT IS ROHS COMPLIANT, AND MEETS EUROPEAN UNION DIRECTIVES AND OTHER COUNTRY REGULATIONS AS PER GS-22-008.
 6. DATE CODE FORMAT: WBY; FOR EXAMPLE: 2207 MEANS WEEK 22 AND YEAR 2007.

rev	ecn no	dr	date
H	N07-0078	HB	2007-03-16
J	N07-0147	LONG	2007-06-29
K	N07-0201	SH	2007-07-28
L	N08-0247	R.B	2008/11/12

www.fciconnect.com		surface	tolerance std	projection	MM
Dr DAVID TENG 2004-10-04		ANGULAR	0.x ±0.30	size A4	Scale 1.000
Eng DAVID TENG 2004-10-04		LINEAR	0.xx ±0.15	ECN N08-0247	
Chr PAUL WANG 2004-10-04		0° ±2°	0.xxx ±0.08		
Appr JOSEPH HSIA 2004-10-04		Product family		Spec ref	
FCJ		TOP SHIELD SUB-ASSEMBLY	catlog no 10030573	Rev. L	
		EXPRESSCARD/34 MODULE CARD KIT	customer	sheet 1 of 5	

REV F - 2004-04-07



Copyright FCI.

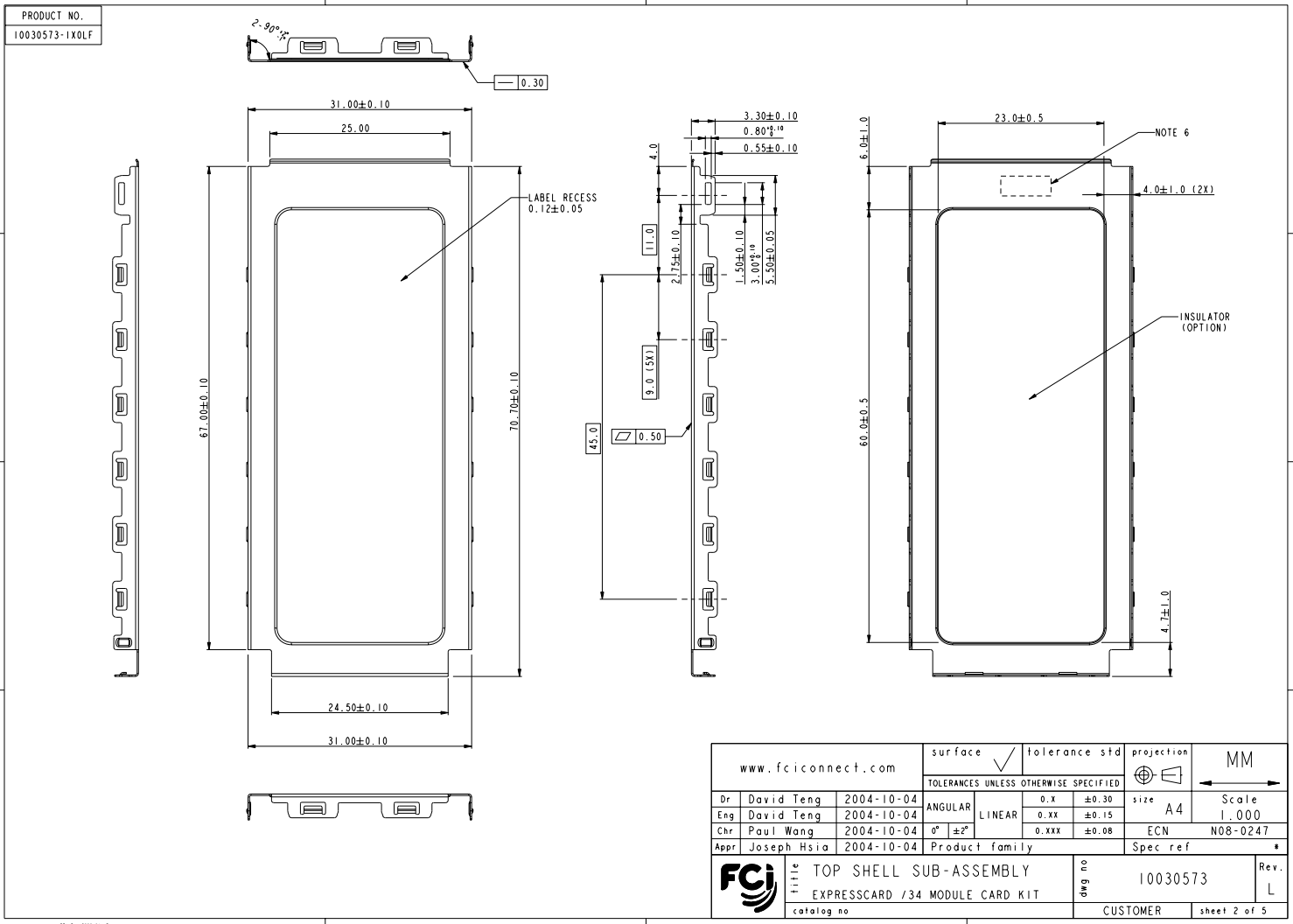

REV 1 - 2004-04-07

3PDM: Rev:L STATUS Released 4 Printed: Oct 12, 2010



Copyright FCI.

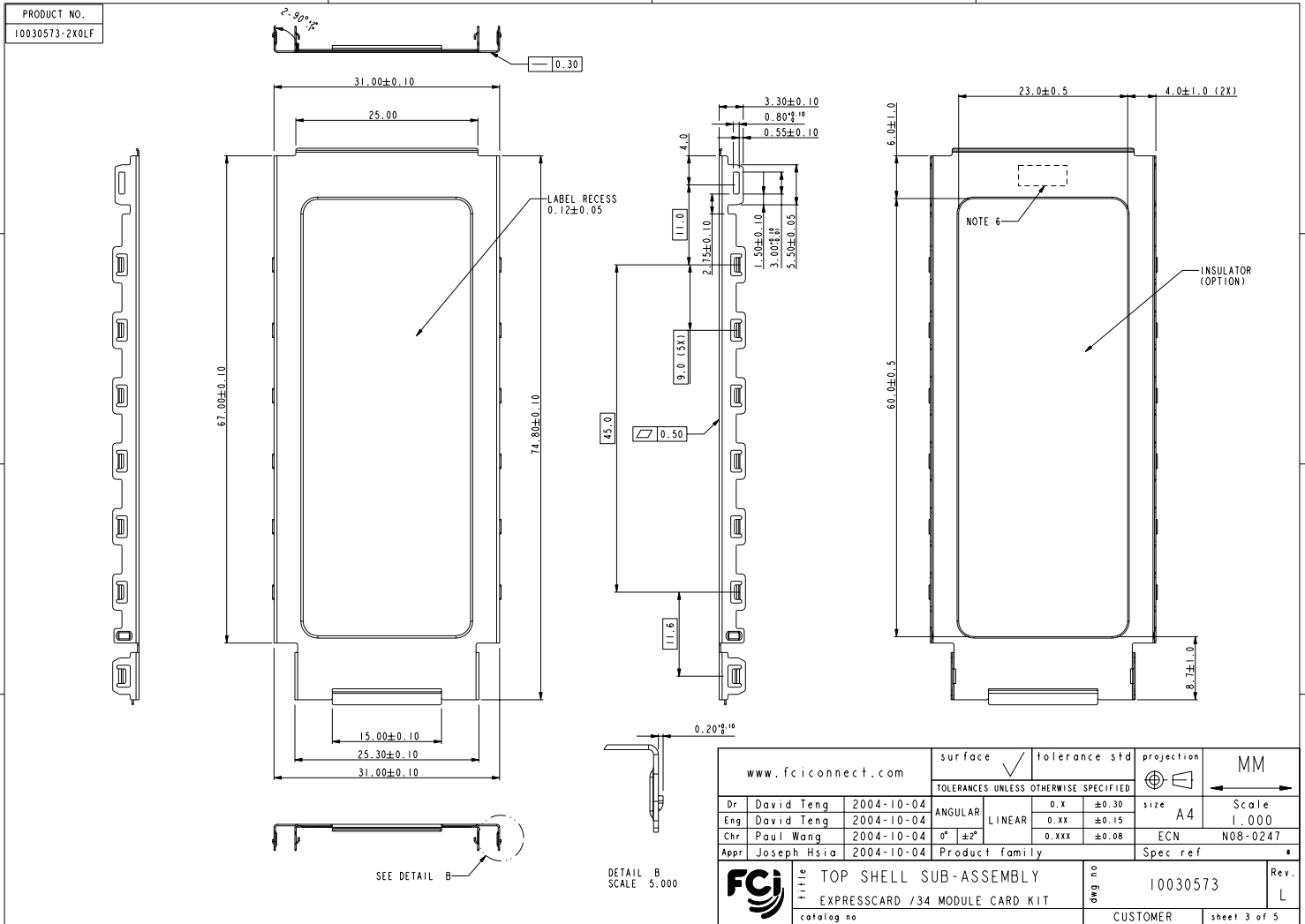

REV 1 - 2004-04-07

3 PDM: Rev:L STATUS Released 4 Printed: Oct 12, 2010

PRODUCT NO.
10030573-201LF

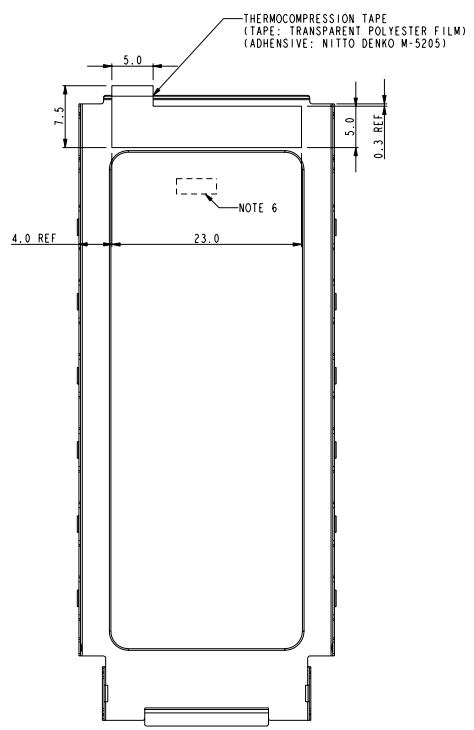
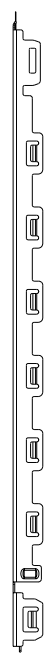
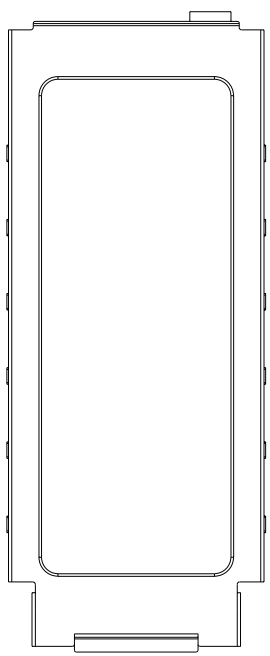

NOTE: ALL DIMENSITONS REFER TO 10030573-2X0LF EXCEPT THERMOCOMPRESSON TAPE

www.fciconnect.com		surface <input checked="" type="checkbox"/>	tolerance std	projection	MM
TOLERANCES UNLESS OTHERWISE SPECIFIED					
Dr	David Teng	2004-10-04	ANGULAR	0.x ±0.30	size A4 Scale 1.000
Eng	David Teng	2004-10-04	LINEAR	0.xx ±0.15	ECN N08-0247
Chr	Paul Wang	2004-10-04	0° ±2°	0.xxx ±0.08	Spec ref
Appr	Joseph Hsia	2004-10-04	Product family		
		TOP SHELL SUB-ASSEMBLY		dwg no	10030573
		EXPRESSCARD /34 MODULE CARD KIT		CUSTOMER	sheet 4 of 5
catalog no				Rev.	L

Copyright FCI.

PART NUMBER
10030573-3X0L.F

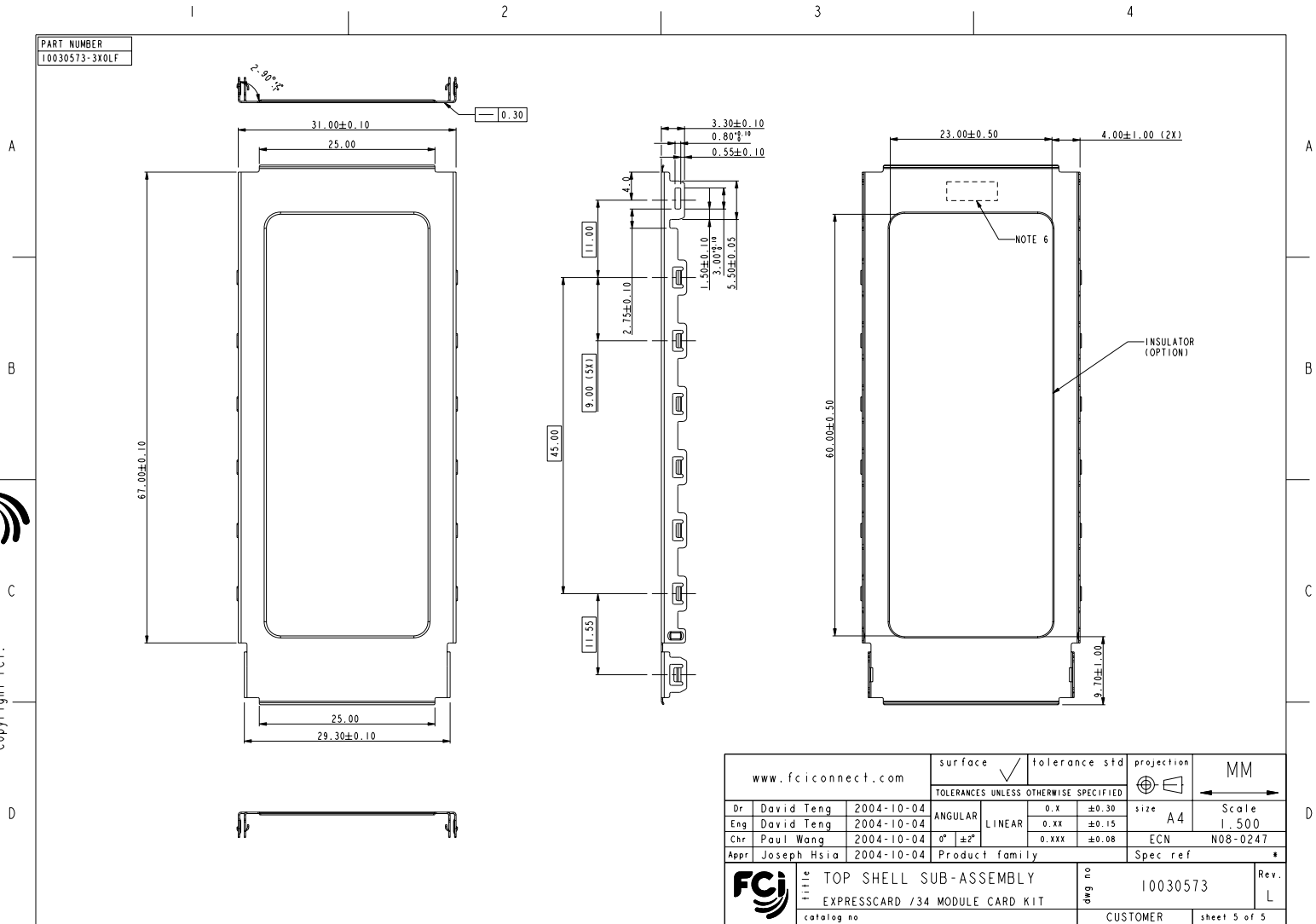

www.fciconnect.com		surface <input checked="" type="checkbox"/>	tolerance std	projection	MM
TOLERANCES UNLESS OTHERWISE SPECIFIED					
Dr	David Teng	2004-10-04	ANGULAR	0.x	±0.30
Eng	David Teng	2004-10-04	LINEAR	0.xx	±0.15
Chr	Paul Wang	2004-10-04	0° ±2°	0.xxx	±0.08
Appr	Joseph Hsia	2004-10-04	Product family	ECN	N08-0247
Title				Spec ref	
TOP SHELL SUB-ASSEMBLY				dwg no	10030573
EXPRESSCARD /34 MODULE CARD KIT				Rev.	L
catalog no				CUSTOMER	sheet 5 of 5

3 PDM: Rev:L STATUS Released 4 Printed: Oct 12, 2010

FCJ
Copyright FCI.