

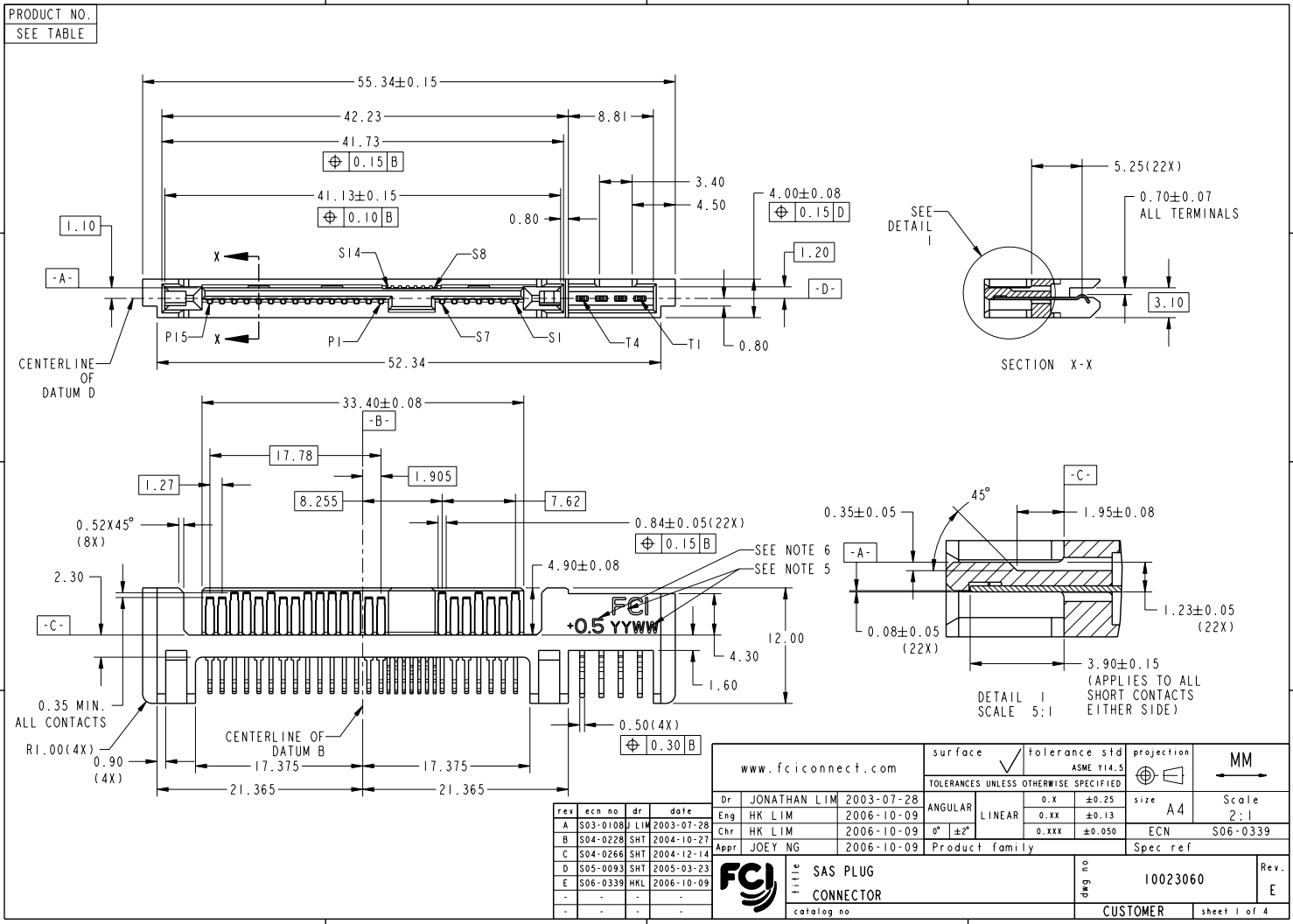

Copyright FCI.



REV E - 2006-09-28

PDM: Rev:E STATUS:Released 4 Printed: Nov 30, 2010



Copyright FCI.

PRODUCT NO.  
SEE TABLE

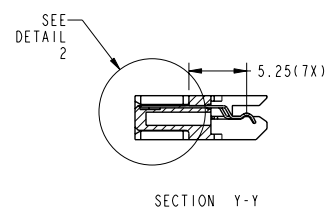
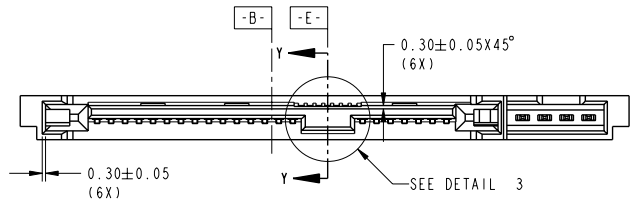
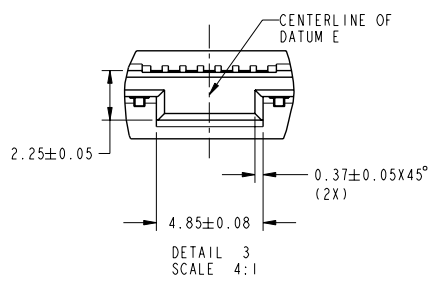
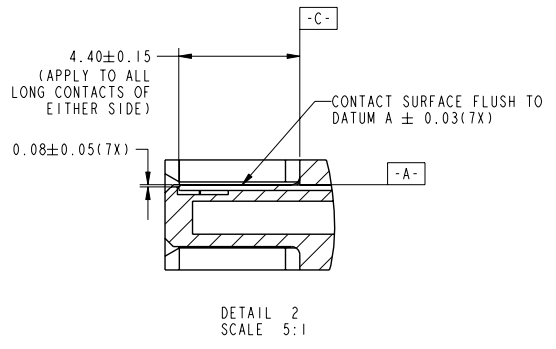
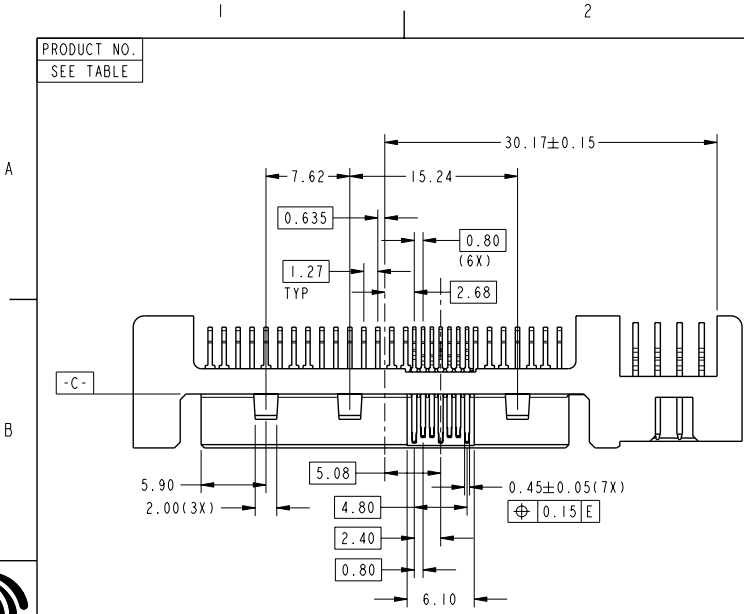

	TITLE	SAS PLUG CONNECTOR	DRG. NO.	10023060	REV.	E
	CATALOG NO.		CUSTOMER		sheet 2 of 4	

PDM: Rev:E STATUS:Released <sup>4</sup>Printed: Nov 30, 2010

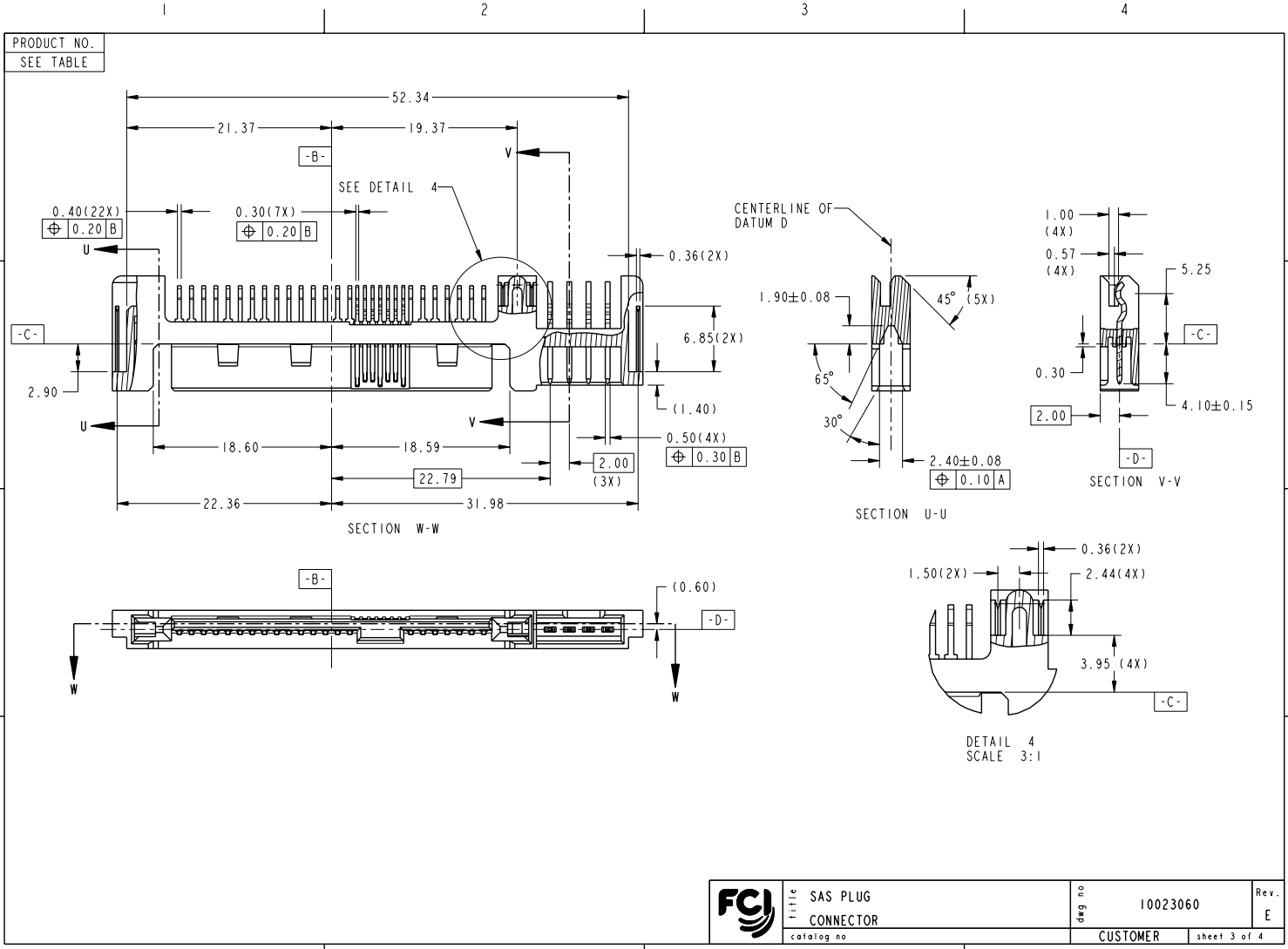

REV E - 2004-03-28



Copyright FCI.

D

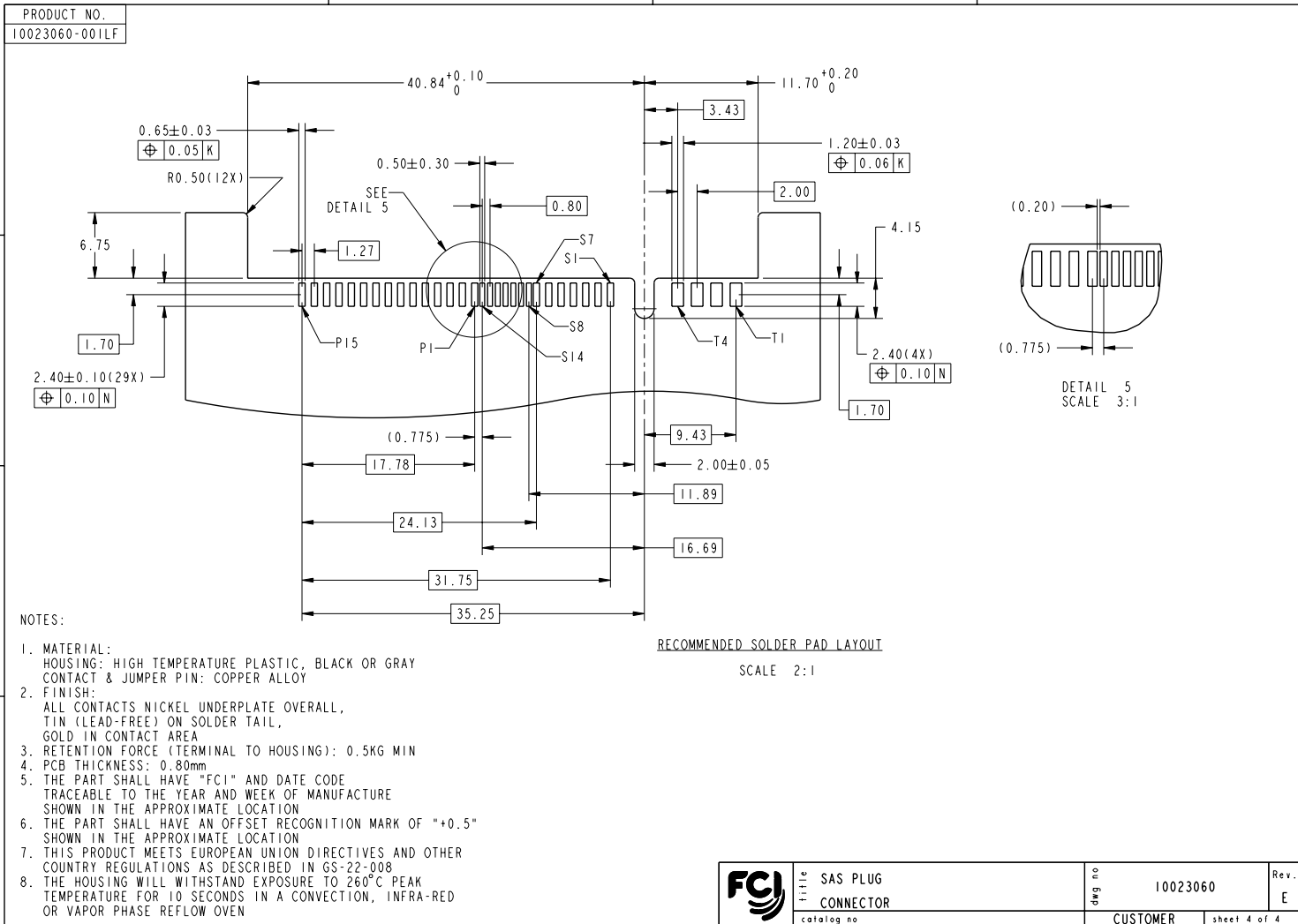

REV E - 2004-03-28

PDM: Rev:E

STATUS:Released<sup>4</sup> Printed: Nov 30, 2010