

Tous droits strictement réservés. Reproduction ou communication à des tiers
Interdite sous quelque forme que ce soit sans autorisation écrite du propriétaire.
Propriété de FCI. Droits de reproduction FCI.

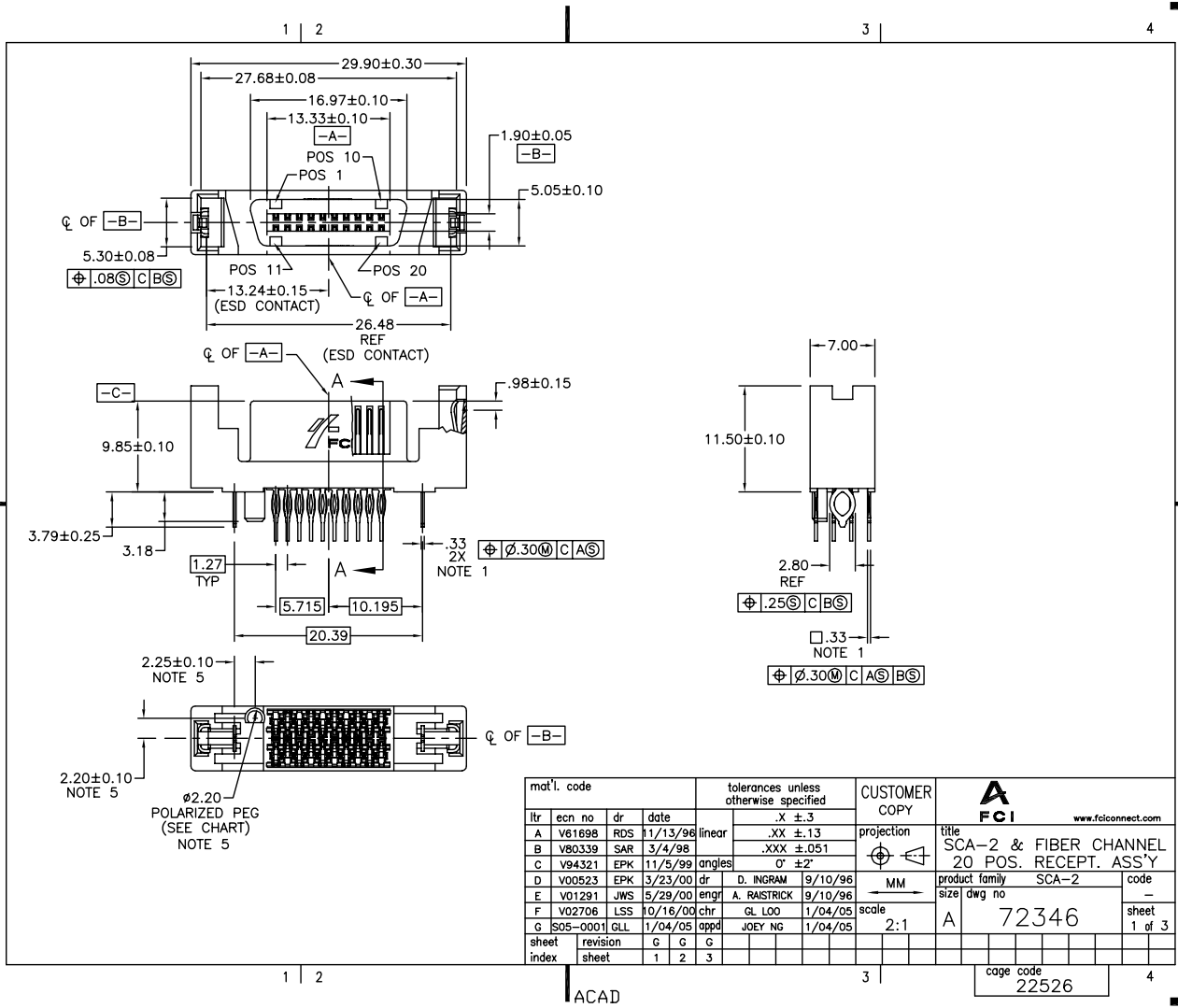

All rights strictly reserved. Reproduction or issue to third parties in any
form whatever is not permitted without written authority from the proprietor.
Property of FCI. Copyright FCI.



mat'l. code		tolerances unless otherwise specified		CUSTOMER COPY		FCI www.fciconnect.com	
ltr	ecn no	dr	date	linear	.X ±.3	projection	title SCA-2 & FIBER CHANNEL 20 POS. RECEPT. ASS'Y
A	V81898	RDS	11/13/98		.XX ±.13	product family SCA-2	
B	V80339	SAR	3/4/98		.XXX ±.051		
C	V94321	EPK	11/5/99	angles	0° ±2'	MM	size A
D	V00523	EPK	3/23/00	dr	D. INGRAM 9/10/96	scale 2:1	dwg no 72346
E	V01291	JWS	5/29/00	engr	A. RAISTRICK 9/10/96		sheet 1 of 3
F	V02706	LSS	10/18/00	chr	GL LOO 1/04/05		
G	IS05-0001	GLL	1/04/05	appd	JOEY NG 1/04/05		
sheet index	revision sheet	G	G	G			cage code 22526

ACAD

PDM: Rev:G

STATUS:Released

Printed: Mar 11, 2011

Tous droits strictement réservés. Reproduction ou communication à des tiers
 Interdite sous quelque forme que ce soit sans autorisation écrite du propriétaire.
 Property of FCI. Copyright FCI. Droits de reproduction FCI.



All rights strictly reserved. Reproduction or issue to third parties in any
 form whatever is not permitted without written authority from the proprietor.
 Property of FCI. Copyright FCI.

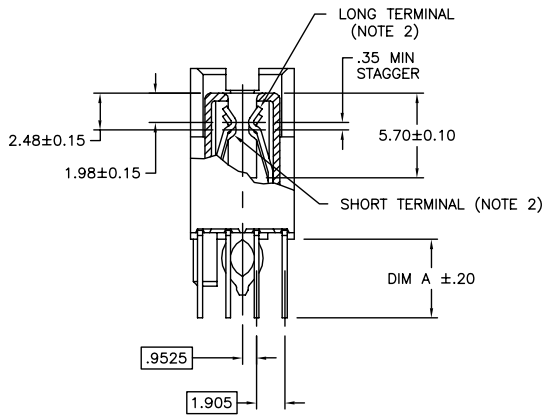

SECTION A-A

mat'l. code		tolerances unless otherwise specified		CUSTOMER COPY		www.fciconnect.com	
ltr	ecn no	dr	date	linear	projection	title	
				.X ±.3		SCA-2 & FIBER CHANNEL	
				.XX ±.13		20 POS. RECEPT. ASS'Y	
				.XXX ±.051		product family	SCA-2
				angles	MM	size	dwg no
				0° ±2'	scale	A	72346
				dr	3:1		sheet
				engr			2 of 3
				chr			
				appd			
sheet index	revision sheet					cage code	
						22526	

ACAD

PDM: Rev:G

STATUS:Released

Printed: Mar 11, 2011

Tous droits strictement réservés. Reproduction ou communication e des tiers
 interdite sous quelque forme que ce soit sans autorisation écrite du propriétaire.
 Property of FCI. Prohibits de reproduction FCI.

All rights strictly reserved. Reproduction or issue to third parties in any
 form whatever is not permitted without written authority from the proprietor.
 Property of FCI. Copyright FCI.

PRODUCT NUMBER	"A" DIM	POLARIZATION PEG	PLATING	RECOMMENDED P.C. BOARD THICKNESS	PRODUCT NUMBER	PLATING	PRODUCT NUMBER	PLATING	PRODUCT NUMBER	PLATING
72346-001	3.79	YES	NOTE ④	2.36mm (0.093") AND 3.18mm (0.125")	72346-101	NOTE ⑥	72346-001LF	NOTE ⑧	72346-101LF	NOTE ⑦
-002	3.79	NO			72346-102		72346-002LF		72346-102LF	
-003	4.60	YES			72346-103		72346-003LF		72346-103LF	
72346-004	4.60	NO	72346-104	72346-004LF	72346-104LF					

NOTE 6 NOTE 8 NOTE 7

NOTES :

- ① TRUE POSITION NOTES APPLY AT TERMINAL TIP.
- ② CONTACTS IN POSITIONS 1 THRU 10 AND 15 AND 16 ARE SHORT TERMINALS. CONTACTS IN POSITIONS 11, 12, 13, 14, AND 17, 18, 19, 20 ARE LONG TERMINALS.
- ③ RAW MATERIALS:
HOUSING: HTN, UL94V-0, COLOR: BLACK
CONTACTS: PHOSPHOR-BRONZE
- ④ CONTACT PLATING: 30u" (0.76um) MIN. GXT PLATING OVER 50u" (1.27um) NICKLE UNDERPLATE IN CONTACT AREA. 20u" (0.5um) MIN-60u" (1.5um) MAX TIN-LEAD PLATING OVER 50u" (1.27um) MIN. NICKLE UNDERPLATE IN P.C. BOARD LEG AREA. 50u" (1.27um) MIN. NICKLE UNDERPLATE OVER REMAINING AREA.
- ⑤ DIMENSIONS DO NOT APPLY TO CONNECTOR STYLES WITHOUT 2.60±0.10 DIA POLARIZATION PEG. (SEE CHART)
- ⑥ CONTACT PLATING: 30u" (0.76um) MIN GOLD PLATING OVER 50u" (1.27um) NICKLE UNDERPLATE IN CONTACT AREA. 20u" (0.5um) MIN-60u" (1.5um) MAX TIN-LEAD PLATING OVER 50u" (1.27um) MIN. NICKLE UNDERPLATE IN P.C. BOARD LEG AREA. 50u" (1.27um) MIN. NICKLE UNDERPLATE OVER REMAINING AREA.
- ⑦ CONTACT PLATING: 30u" (0.76um) GOLD PLATING OVER 50u" (1.27um) NICKLE UNDERPLATE IN CONTACT AREA. 20u" (0.5um) MIN-60u" (1.5um) TIN PLATING OVER 50u" (1.27um) MIN. NICKLE UNDERPLATE IN P.C. BOARD LEG AREA. 50u" (1.27um) NICKLE UNDERPLATE OVER REMAINING AREA.
- ⑧ CONTACT PLATING: 30u" (0.76um) GXT PLATING OVER 50u" (1.27um) NICKLE UNDERPLATE IN CONTACT AREA. 20u" (0.5um) MIN-60u" (1.5um) TIN PLATING OVER 50u" (1.27um) MIN. NICKLE UNDERPLATE IN P.C. BOARD LEG AREA. 50u" (1.27um) NICKLE UNDERPLATE OVER REMAINING AREA.
- ⑨ THE HOUSING WILL WITHSTAND EXPOSURE TO 260°C PEAK TEMPERATURE FOR 10 SECONDS IN A CONVECTION, INFRA RED VAPOR PHASE REFLOW OVEN.
- ⑩ THIS PRODUCT MEETS EUROPEAN UNION DIRECTIVES AND OTHER COUNTRY REGULATIONS AS DESCRIBED IN GS-22-008.

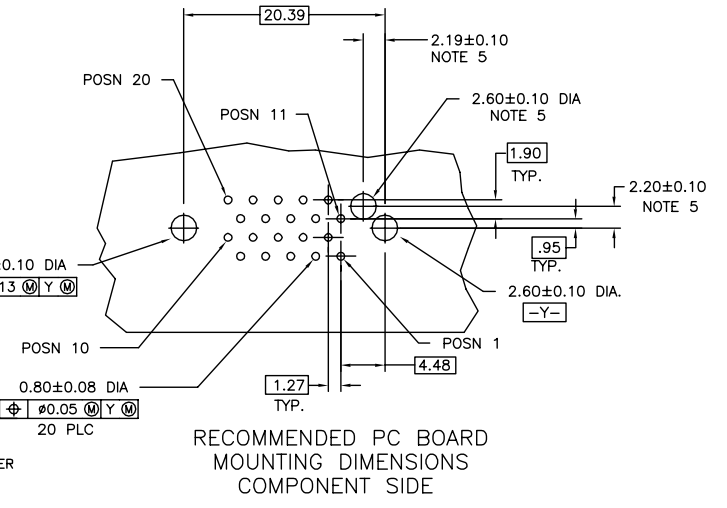

RECOMMENDED PC BOARD MOUNTING DIMENSIONS COMPONENT SIDE

mat'l. code		tolerances unless otherwise specified		CUSTOMER COPY		www.fciconnect.com	
ltr	ecn no	dr	date	linear	.X ±.3	projection	title
g					.XX ±.13		SCA-2 & FIBER CHANNEL
				angles	.XXX ±.051		20 POS. RECEPT. ASS'Y
				dr	0 ±.2	product family	SCA-2
				engr	D. INGRAM 9/10/96	size	dwg no
				chr	A. RAWSTRICK 9/10/96	scale	72346
				appd	GL LOO 1/04/05	sheet	3 of 3
					JOEY NG 1/04/05		
sheet index	revision sheet						

1 | 2 3 | 4 cage code 22526

ACAD