

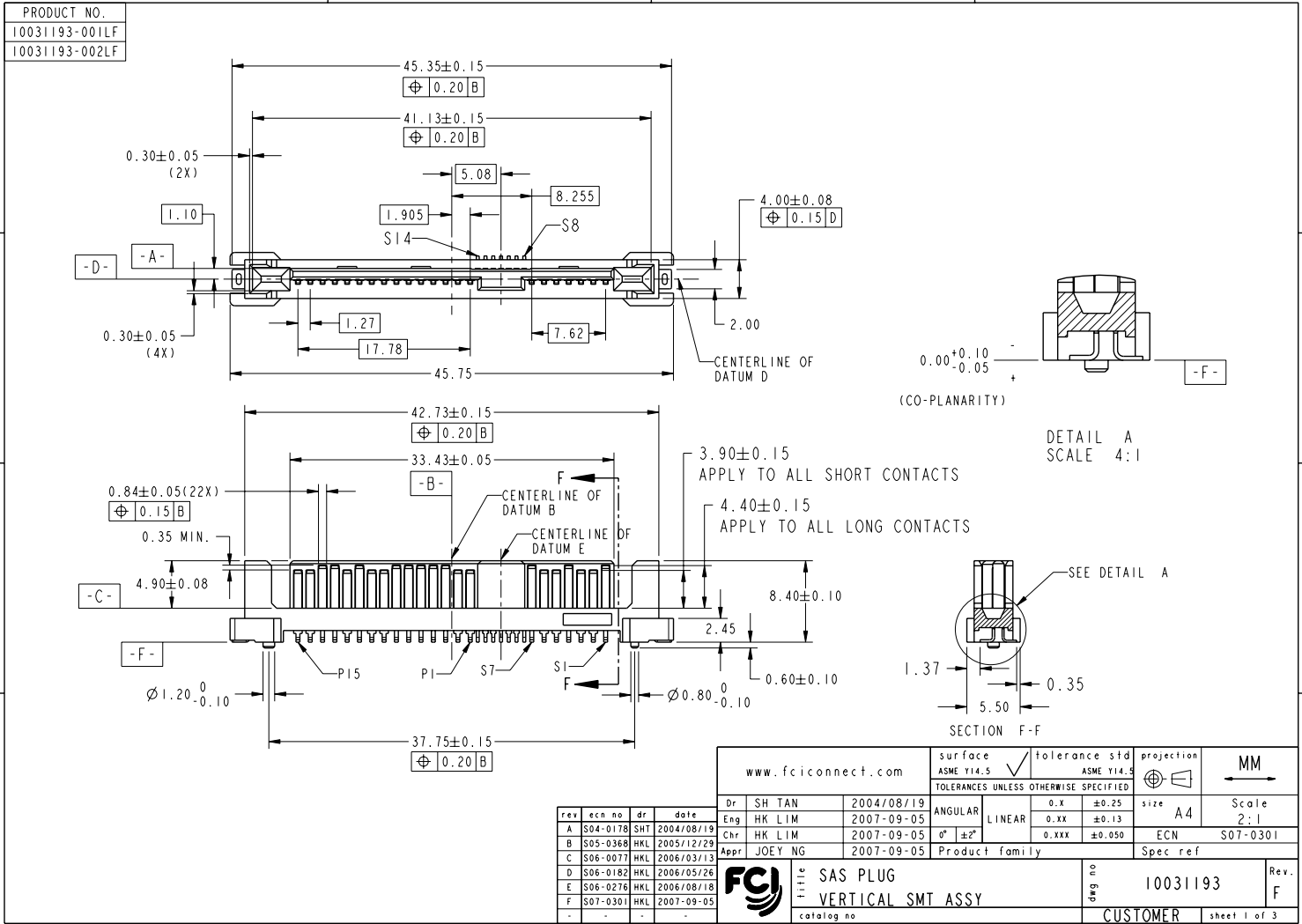

Copyright FCI.



REV E - 2004-03-28

3PDM: Rev:F

4STATUS:Released

4Printed: Nov 30, 2010

PRODUCT NO.
SEE TABLE

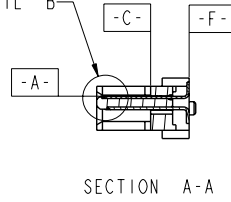
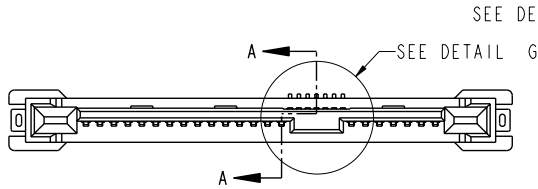
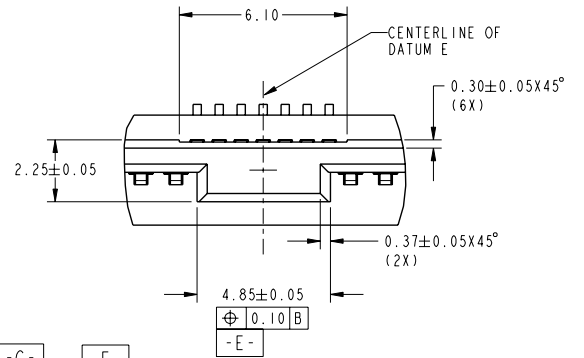
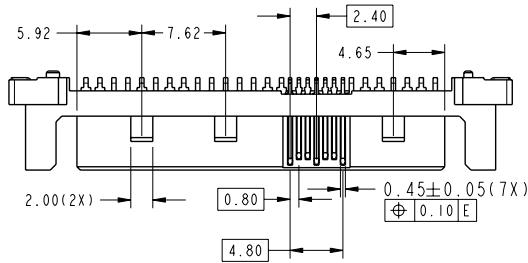

DETAIL G
SCALE 5:1

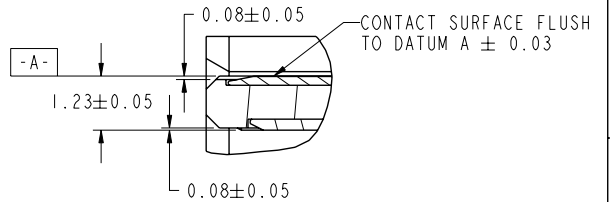
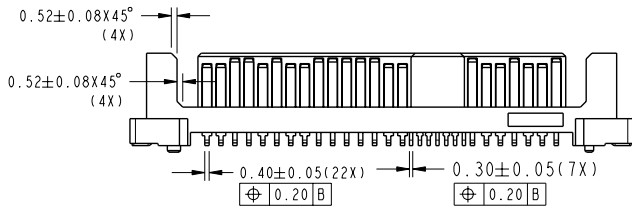

DETAIL B
SCALE 8:1

	title	SAS PLUG VERTICAL SMT ASSY	drwg no	10031193	Rev.	F
	catalog no		CUSTOMER	sheet	2 of 3	

REV E - 2004-03-28

PDM: Rev:F STATUS:Released⁴ Printed: Nov 30, 2010

PRODUCT NO.	WITH PICK-UP CAP	PACKAGING	PLATING SPEC.
10031193-001LF/-002LF	NO	TRAY	-001LF REFER TO NOTE 2A
10031193-001CLF/-002CLF	YES	TAPE & REEL	-002LF REFER TO NOTE 2B
10031193-001C-TRLF/-002C-TRLF			

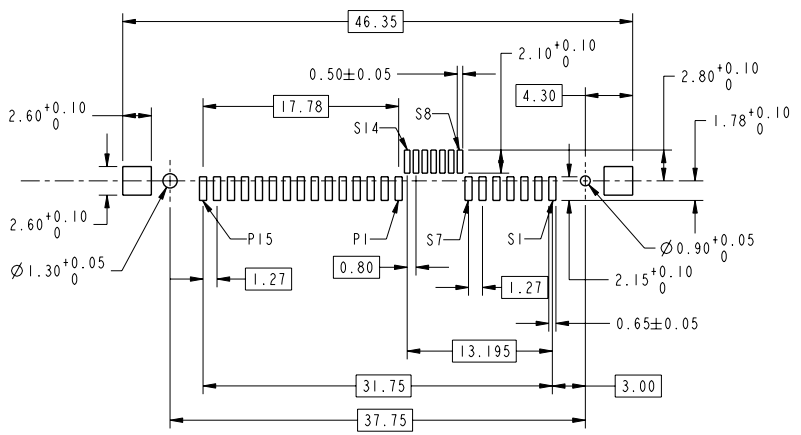
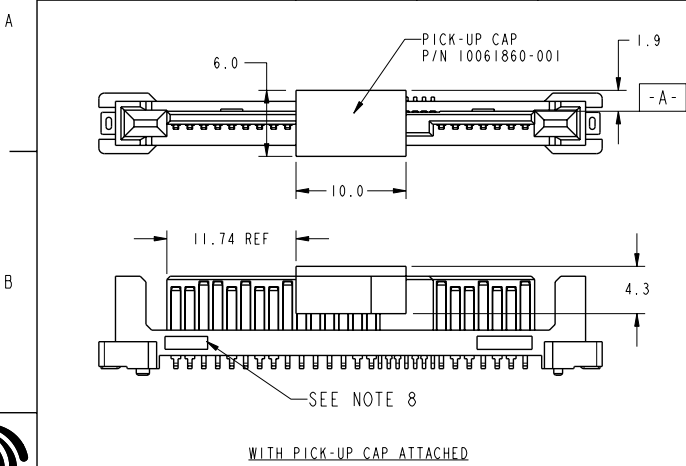

RECOMMENDED SOLDER PAD LAYOUT

- NOTES: -
- MATERIAL:
HOUSING: HIGH TEMPERATURE PLASTIC, BLACK, UL94V-0
CONTACT: COPPER ALLOY
HOLD DOWN: COPPER ALLOY
PICK-UP CAP: HIGH TEMPERATURE PLASTIC, BLACK, UL94V-0
 - FINISH:
CONTACT: 1.27um MIN. NICKEL UNDERPLATE OVERALL,
1.91um MIN. 100% MATTE TIN ON SOLDER TAIL,
A) 0.76um MIN. GOLD ON CONTACT AREA
B) 0.76um MIN. GXT™ ON CONTACT AREA
HOLD DOWN: 2.54um MIN. 100% MATTE TIN OVER 1.27um MIN. NICKEL UNDERPLATE
 - THIS PRODUCT MEETS EUROPEAN UNION DIRECTIVES AND OTHER COUNTRY REGULATIONS AS DESCRIBED IN GS-22-008
 - THE HOUSING WILL WITHSTAND EXPOSURE TO 260°C PEAK TEMPERATURE FOR 10 SECONDS IN A CONVECTION, INFRA-RED OR VAPOR PHASE REFLOW OVEN
 - PART WITH PICK-UP CAP, P/N XXXXXXXX-XXXCLF
 - FOR TAPE & REEL PACKAGING, P/N XXXXXXXX-XXXC-TRLF
 - ASSY DIMENSIONS WITH REFERENCE TO SFF-8482 REV 1.7
 - THE PART SHALL HAVE "FCI" ID AND CAVITY NUMBER SHOWN IN THE APPROXIMATE LOCATION

	title	SAS PLUG	drug no	10031193	Rev.	F
	catalog no	VERTICAL SMT ASSY	CUSTOMER	sheet 3 of 3		

3PDM: Rev:F STATUS:Released 4Printed: Nov 30, 2010

Copyright FCI.