

4

3

2

1

THIS DRAWING IS UNPUBLISHED. RELEASED FOR PUBLICATION AUG. 2006.
 COPYRIGHT - BY TYCO ELECTRONICS CORPORATION. ALL RIGHTS RESERVED.

LOC	DIST	REVISIONS			
P	LTR	DESCRIPTION	DATE	DWN	APVD
SEE SHEET 1.					

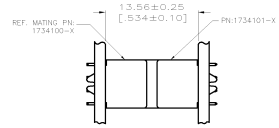
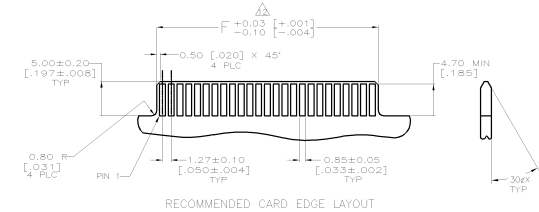
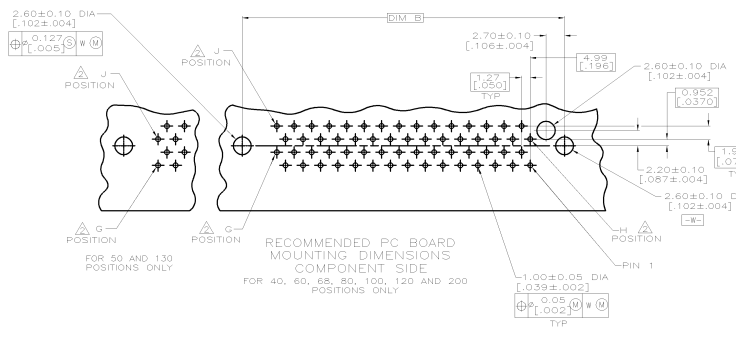

VERTICAL RECEPTACLE ASSEMBLY MATED TO VERTICAL PLUG ASSEMBLY

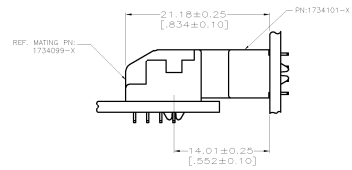
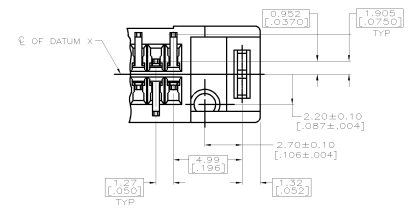
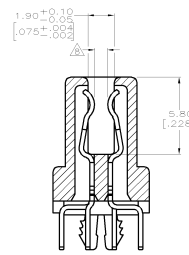

VERTICAL RECEPTACLE ASSEMBLY MATED TO VERTICAL PLUG ASSEMBLY

THIS DRAWING IS A CONTROLLED DOCUMENT.		DWN	STE TE Connectivity	
DIMENSIONS: MM		CHK		
TOLERANCES UNLESS OTHERWISE SPECIFIED:		APVD	NAME	
0 PLC	±	PRODUCT SPEC	RECEPTACLE ASSEMBLY, VERTICAL, BOARD-TO-BOARD, CHAMP.050, SERIES I,	
1 PLC	±	QUALIFICATION TEST REPORT	SIZE	CAGE CODE
2 PLC	±	WEIGHT	A3	00779
3 PLC	±	CUSTOMER DRAWING	DRAWING NO	1734101
4 PLC	±	SCALE	RESTRICTED TO	
ANGLES	±	SHEET	2 of 4	
MATERIAL	FINISH	REV	E	

4

3

2

1

THIS DRAWING IS UNPUBLISHED. RELEASED FOR PUBLICATION AUG. 2006.
 © COPYRIGHT - BY TYCO ELECTRONICS CORPORATION. ALL RIGHTS RESERVED.

LOC	DIST	REVISIONS				
P	LTR	DESCRIPTION	DATE	DWN	APVD	
SEE SHEET 1.						

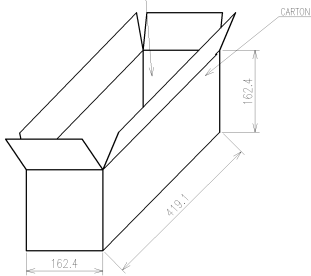
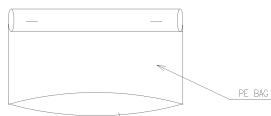
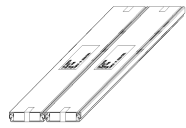
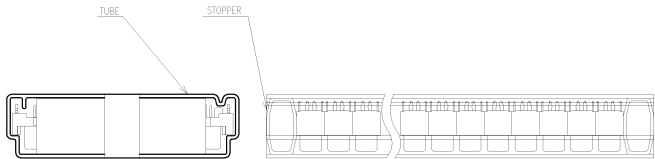

G.W./CARTON (KG)	N.W./CARTON (KG)	PCS/TUBE	TUBES/CARTON	QUANTITY/CARTON (PCS)	PART NUMBER	POS.
4.21	2.89	54	8	432	5-1734101-3 3-1734101-3 1-1734101-3 5-1734101-2 3-1734101-2 1-1734101-2	120
6.84	4.92	54	16	864	5-1734101-1 3-1734101-1 1-1734101-1 5-1734101-0 3-1734101-0 1-1734101-0	100
5.61	4.06	54	16	864	5-1734101-8 3-1734101-8 1-1734101-8 4-1734101-8 6-1734101-8 1734101-8	80
5.05	3.63	54	16	864	4-1734101-7 6-1734101-7 1734101-7	68
4.28	3.11	54	16	864	4-1734101-6 6-1734101-6 1734101-6	60
4.72	3.42				2-1734101-7 5-1734101-7 3-1734101-7	
5.32	4.02	54	24	1296	1-1734101-7 4-1734101-5 6-1734101-5 1734101-5	50
4.42	3.37	54	24	1296	4-1734101-4 6-1734101-4 1734101-4	40
6.25	5.36	54	32	1728	4-1734101-3 6-1734101-3 1734101-3	30

THIS DRAWING IS A CONTROLLED DOCUMENT.		DWN
DIMENSIONS: MM		CHK
TOLERANCES UNLESS OTHERWISE SPECIFIED:		APVD
0 PLC	± -	PRODUCT SPEC
1 PLC	± -	QUALIFICATION TEST REPORT
2 PLC	± -	WEIGHT
3 PLC	± -	CUSTOMER DRAWING
4 PLC	± -	
ANGLES	± -	
MATERIAL	FINISH	

STE TE Connectivity

NAME

RECEPTACLE ASSEMBLY, VERTICAL, BOARD-TO-BOARD, CHAMP.050, SERIES I,

SIZE CAGE CODE DRAWING NO. RESTRICTED JO

A3 00779 C-1734101

SCALE SHEET 3 of 4 REV E

4

3

2

1

THIS DRAWING IS UNPUBLISHED. RELEASED FOR PUBLICATION AUG. 2006.
 © COPYRIGHT - BY TYCO ELECTRONICS CORPORATION. ALL RIGHTS RESERVED.

LOC	DIST	REVISIONS				
P	LTR	DESCRIPTION	DATE	DWN	APVD	
SEE SHEET 1.						

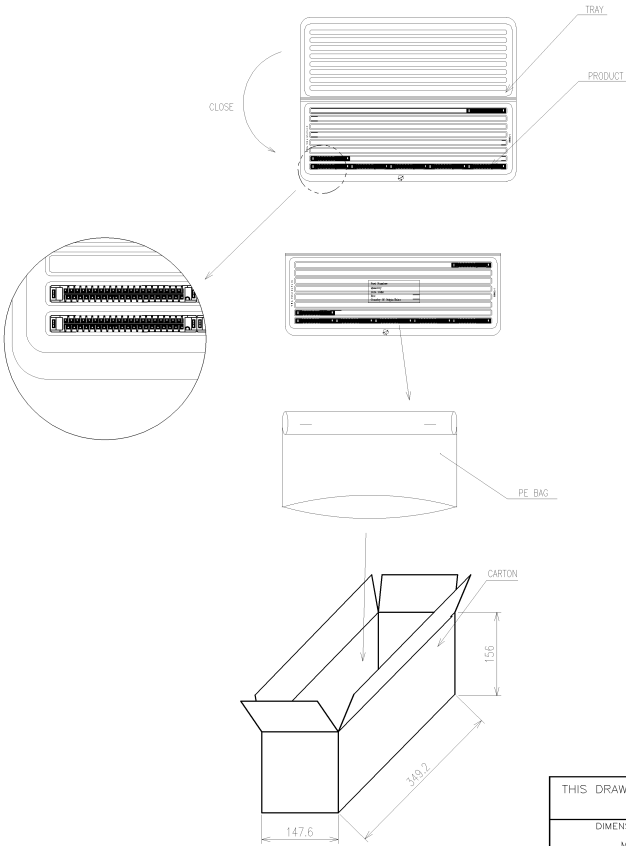

G.W./CARTON (KG)	N.W./CARTON (KG)	PCS/TRAY	TRAYS/CARTON	QUANTITY/CARTON (PCS)	PART NUMBER	POS.
2.69	1.71	16	10	160	5-1734101-6	200
					3-1734101-6	
					1-1734101-6	
2.37	1.39	16	10	160	5-1734101-5	160
					3-1734101-5	
					1-1734101-5	
2.48	1.50	32	10	320	5-1734101-4	80
					3-1734101-4	
					1-1734101-4	
					4-1734101-9	80
					6-1734101-9	
					1734101-9	

THIS DRAWING IS A CONTROLLED DOCUMENT.

DIMENSIONS: MM	TOLERANCES UNLESS OTHERWISE SPECIFIED:	DWN	CHK	 RECEPTACLE ASSEMBLY, VERTICAL, BOARD-TO-BOARD, CHAMP.050, SERIES I,
	0 PLC ± -	APVD	NAME	
MATERIAL	1 PLC ± -	PRODUCT SPEC	SIZE CAGE CODE DRAWING NO	
FINISH	2 PLC ± -	QUALIFICATION TEST REPORT	RESTRICTED TO	
	3 PLC ± -	WEIGHT	A3 00779 C-1734101	
	4 PLC ± -	CUSTOMER DRAWING	SCALE	SHEET 4 of 4
	ANGLES ± -			REV E