

REVISONS		DATE	BY	APPD
P	LYA			
C3	REVISE NOTE 3	16MAR2009	BB	SB
D	REV PER ECR-09-009262	24APR2009	BB	CB
E	REV PER ECR-10-009334	12MAR2010	IL	CT
E1	REV PER ECR-11-010923	31MAR2011	LL	CT

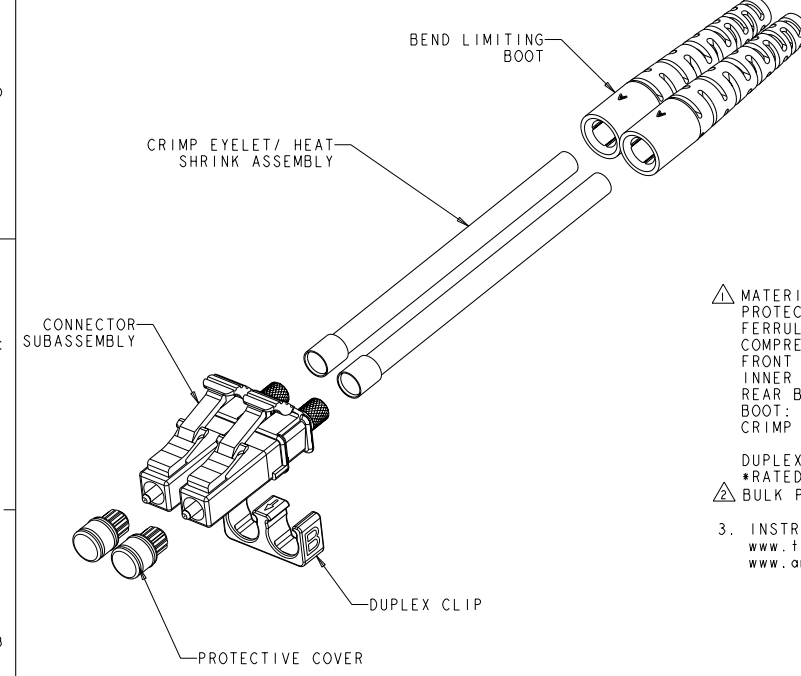

△ MATERIAL  
 PROTECTIVE COVER: TPE, COLOR: BLACK, UL94 HB\*  
 FERRULE SUBASSEMBLY: ZIRCONIA/METAL  
 COMPRESSION SPRING: STAINLESS STEEL  
 FRONT HOUSING: PEI, COLOR: BEIGE, UL94 V-0\*  
 INNER TUBING: PTFE, COLOR: CLEAR, UL VW-I  
 REAR BODY: METAL  
 BOOT: PP, UL94 V-0\*. SEE TABLE FOR COLOR.  
 CRIMP EYELET/HEAT SHRINK ASSY: ALUM. ALLOY, HEAT SHRINK: POLYOLEFIN, UL VW-I, COLOR: WHITE AND YELLOW  
 DUPLEX CLIP: PEI, COLOR: BEIGE, UL94 V-0\*  
 \*RATED AT QUALIFYING THICKNESS.  
 △ BULK PACKAGED.

3. INSTRUCTION SHEET: 408-8675 AVAILABLE FOR DOWNLOAD AT  
[www.tycoelectronics.com/documents](http://www.tycoelectronics.com/documents) OR  
[www.ampnetconnect.com/foguide](http://www.ampnetconnect.com/foguide).

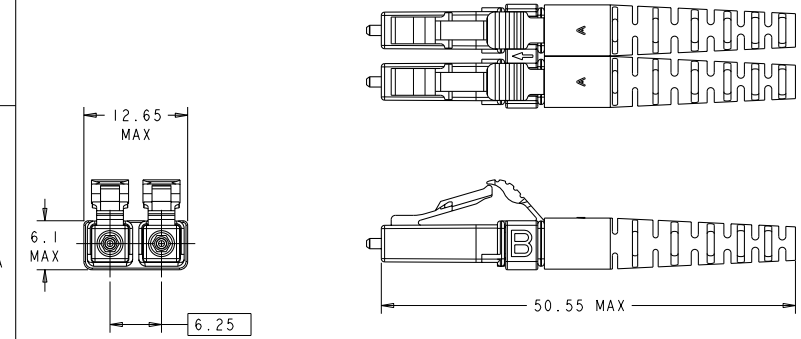

HEAT SHRINK COLOR	BOOT COLOR	PART NUMBER
WHITE	BLUE	1918373-8
WHITE/YELLOW	BEIGE	1918373-7
WHITE	BLACK	1918373-6
WHITE	AQUA	1918373-5
WHITE	BLACK	1918373-4
WHITE	AQUA	1918373-3
WHITE	BEIGE	1918373-2
WHITE	BEIGE	1918373-1

THIS DRAWING IS A CONTROLLED DOCUMENT. DWG: B. BRIGGS 21APR2006  
 CDR: D. ROHDE 21APR2006  
 APPRO: D. BAICHTLE 21APR2006

DIMENSIONS: mm  
 TOLERANCES UNLESS OTHERWISE SPECIFIED:  
 0 PLC ±.1  
 1 PLC ±.1  
 2 PLC ±.1  
 3 PLC ±.1  
 4 PLC ±.1  
 ANGLES ±.1

MATERIAL: △ - FINISH: -  
 WEIGHT: -  
 CUSTOMER DRAWING

NAME: D. BAICHTLE  
 PRODUCT SPEC: -  
 APPLICATION SPEC: -  
 SIZE: A2  
 CASE CODE: -  
 DRAWING NO: 1918373  
 SCALE: 3:1  
 SHEET 1 OF 1  
 REV: E1

**TE** TE Connectivity  
 KIT, CONNECTOR, LC, DUPLEX, MM, 1.6-2.0mm JACKET