

3M™ D Sub EMI Junction Shell

50 Position

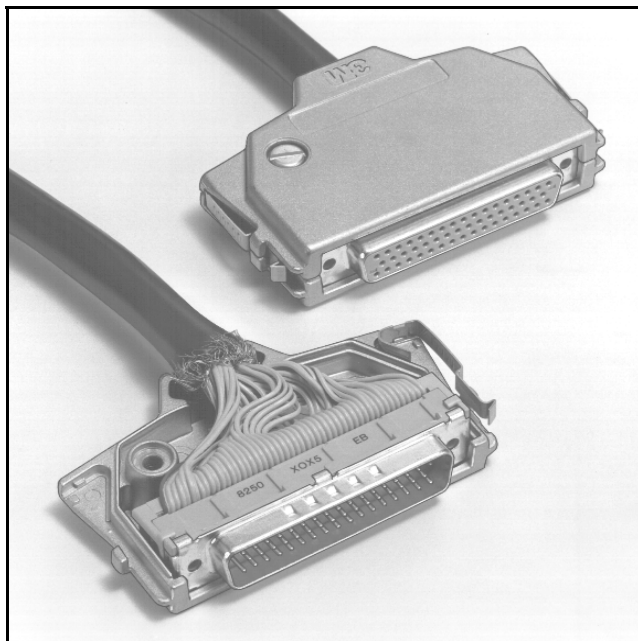

- Cast aluminum shell provides EMI/ESD protection
- Spring latch allows positive, quick and easy connect and disconnect
- Strain relief compensates for various round cable outside diameters
- Nickel plating provides attractive and corrosion-resistant features
- RoHS* compliant

Date Modified: January 15, 2007

TS-0245-08
Sheet 1 of 2

Physical

Junction Shell Kit

Hardware Included: (2) Shell Halves - Die Cast Aluminum Alloy, Clear Chromate
(2) 8 × 32 × 3/8 - Steel, Zinc
(2) Latch - Stainless Steel
(1) Tape Strip

Latch Bracket Kit

Hardware Included: (1) Bracket - Stainless Steel
(2) Screws #4-40 × 7/16 - Steel, Zinc
(6) Flat Washers - Steel, Zinc
(2) Spring Washers - Steel, Zinc

"RoHS compliant" means that the product or part does not contain any of the following substances in excess of the following maximum concentration values in any homogeneous material, unless the substance is in an application that is exempt under RoHS: (a) 0.1% (by weight) for lead, mercury, hexavalent chromium, polybrominated biphenyls or polybrominated diphenyl ethers; or (b) 0.01% (by weight) for cadmium. Unless otherwise stated by 3M in writing, this information represents 3M's knowledge and belief based upon information provided by third party suppliers to 3M.

3M™ D Sub EMI Junction Shell

50 Position

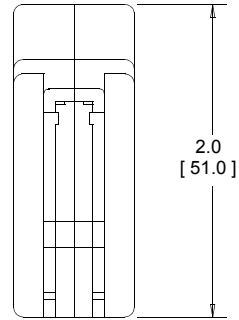
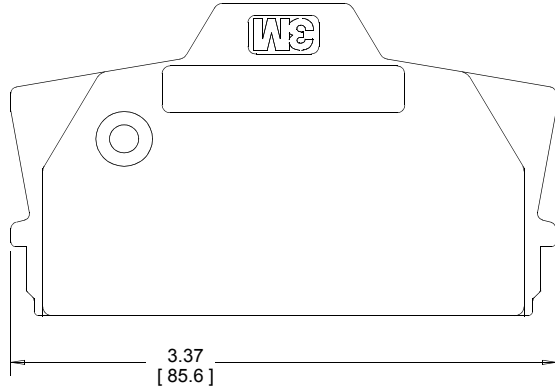
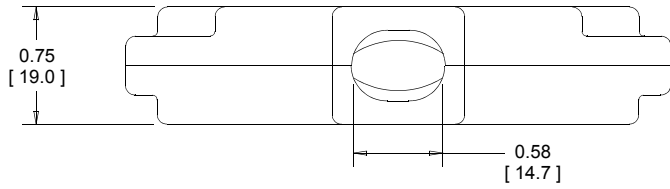

Junction Shell

Inch
[mm]

Tolerance Unless Noted			
	.0	.00	.000
inch	±.1	±.01	±.005

[] Dimensions for Reference Only

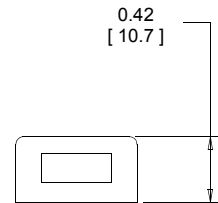
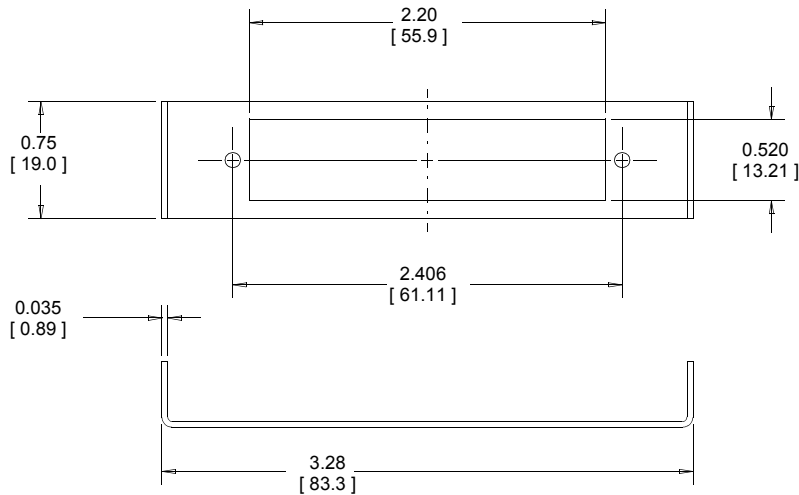

Latch Bracket

Note: Maximum Panel Thickness for Latch Bracket is 3/32".

Ordering Information

Junction Shell

3357-9250

**Latch Bracket
(Order Separately)**

3505-62

TS-0245-08
Sheet 2 of 2

Important Notice

All statements, technical information, and recommendations related to 3M's products are based on information believed to be reliable, but the accuracy or completeness is not guaranteed. Before using this product, you must evaluate it and determine if it is suitable for your intended application. You assume all risks and liability associated with such use. Any statements related to the product which are not contained in 3M's current publications, or any contrary statements contained on your purchase order shall have no force or effect unless expressly agreed upon, in writing, by an authorized officer of 3M.

3M

3M Electronics

6801 River Place Blvd.
Austin, TX 78726-9000
800/225-5373
www.3M.com/electronics

Warranty; Limited Remedy; Limited Liability.

This product will be free from defects in material and manufacture for a period of one (1) year from the time of purchase. **3M MAKES NO OTHER WARRANTIES INCLUDING, BUT NOT LIMITED TO, ANY IMPLIED WARRANTY OF MERCHANTABILITY OR FITNESS FOR A PARTICULAR PURPOSE.** If this product is defective within the warranty period stated above, your exclusive remedy shall be, at 3M's option, to replace or repair the 3M product or refund the purchase price of the 3M product. **Except where prohibited by law, 3M will not be liable for any indirect, special, incidental or consequential loss or damage arising from this 3M product, regardless of the legal theory asserted.**



*Minimum 10%
Post-Consumer Fiber*

Printed in USA.

© 3M 2007