

REFERENCE SPECIFICATIONS

-NFC 93425 (in compliance with HE 507)

PHYSICAL CHARACTERISTICS

- INSULATOR MATERIAL: THERMOPLASTIC .UL94V0
- ACCESSORIES: BRASS
- SHELLS: STEEL

ELECTRICAL CHARACTERISTICS

- CONTACT/CONTACT : >=1000 V
- CONTACT/GROUND : >=1200 V
- INSULATION RESISTANCE: >=5000 MOhms

ENVIRONMENTAL CHARACTERISTICS

- CLIMATIC CATEGORY: 55/125/21
- TEMPERATURE RANGE -55°C TO +125°C
- DAMP HEAT STEADY STATE 21 DAYS
- SALT SPRAY 24 HOURS

MECHANICAL CHARACTERISTICS

- RETENTION AGAINST TORQUE:
 - Threaded insert: 0.7 N.m minimum
 - Female screw : 0.5 N.m minimum

Series ← **DBL5W5PA00LF**

Shell size: E A B C
see sheet 2

Front accessory definition
see sheet 2

- Blank : Without accessory
- L : Threaded insert M3
- O : Threaded insert UNC 4-40
- V : Female screw UNC 4-40

Layout of contacts (see sheet 3)

Contacts

- P :Pin

PCB accessory definition

- A without accessory on PCB

Power contacts

- Q0 without power contact

See note RoHS

NOTE RoHS INFORMATION

- The "LF" products meet european union Directives and other country regulations as described in GS-22-008.
- Shell plating :2 to 4µm Cu + Ni + 3 to 10µmm Sn(pure bright)
- Accessories: Sn pure bright + nickel
- Packaging spec: See GS-14-920



rev	ech no	dr	date	Dr	date	surface	tolerance std	projection	mm
A	LS06-0113	HPE	2005-11-28	M. PESSON	2005-10-11	ANGULAR	ISO 1102	ISO 1101	A2
B	LS06-0708	LGO	2006-12-13	P. LEGARE	2005-10-11	LINEAR	0.X	0.3	2:1
C	LS07-0273	HPE	2007/11/05			0" 1/32"	0.XX	0.1	ECN
D	F09-0076	LSA	2009-08-20			0.XXX	0.05	0.05	Spec ref
E	F10-0017	LSA	2010-03-10						

www.fciconnect.com		surface	-	tolerance std	ISO 1102	ISO 1101	projection	mm
		TOLERANCES UNLESS OTHERWISE SPECIFIED						
		ANGULAR	LINEAR	0.X	0.3	0.1	A2	Scale 2:1
		0" 1/32"	0.XXX	0.05	0.05		ECN	F09-0076
		Product family				Spec ref		
FCI		SUB MALE DW		C01-8639-2315		Rev.		E
Catalog no		full power without contact		CUSTOMER		sheet 1 of 4		

Copyright FCI

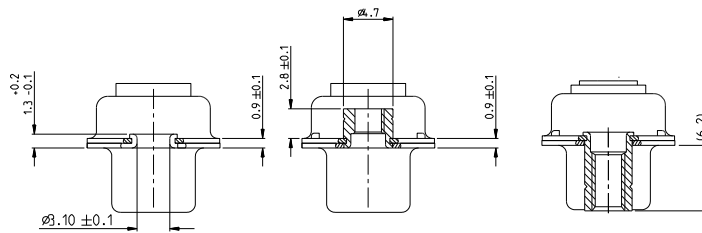

FRONT ACCESSORY	Blank without	L insert M3 O insert UNC 4.40	V Female screw UNC 4-40
PCB ACCESSORIES	A without	A without	A without

PART NUMBER	FRONT ACCESSORY	PCB ACCESSORY
D*xW xPA00LF	W ITHOUT	W ITHOUT
D*YxW xPA00LF	Female screw UNC 4-40	W ITHOUT
D*LxW xPA00LF	Insert M3	W ITHOUT
D*OxW xPA00LF	Insert UNC 4-40	W ITHOUT

shell size LAYOUTS

- xW x
- E 2V2
- A 3V3
- A 3W3
- B 5W5
- C 8W8

Copyright FCI

www.fciconnect.com		surface ISO 1502	tolerance std ISO 406 ISO 1101	projection	mm
TOLERANCES UNLESS OTHERWISE SPECIFIED		ANGULAR	LINEAR	size	Scale
Df M. PESSON	2005-10-11	0.x	0.xx	A2	2:1
Cr P. LEGARE	2005-10-11	0" 1/32"	0.xxx	ECN	F09-0076
Apr		Product family		Spec ref	
SUB MALE DW full power without contact				C01-8639-2315	Rev. E
Customer no.				CUSTOMER	sheet 2 of 4

2V2

3V3

3W3

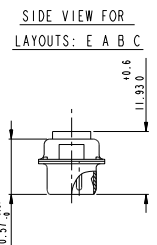
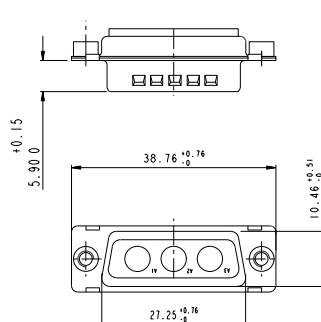
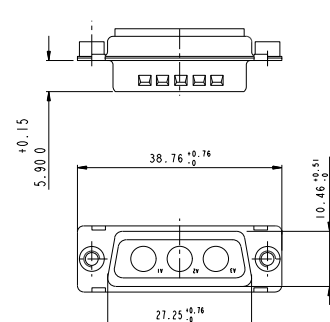
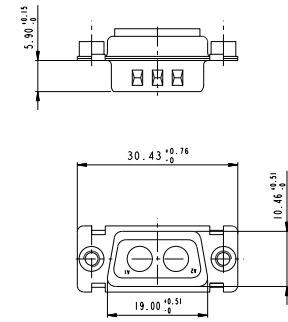
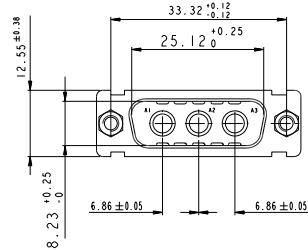
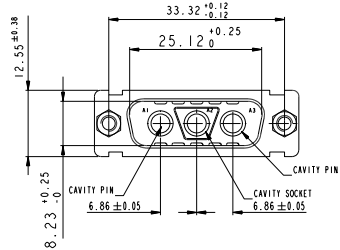
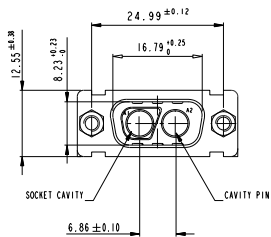

Copyright FCI

www.fciconnect.com		surface 150 1302	tolerance std 150 406 150 1101	projection 150 1101	mm
TOLERANCES UNLESS OTHERWISE SPECIFIED					
Dr	M. PESSON	2005-10-11	ANGULAR	0.X	±0.3
Eng	P. LEGARE	2005-10-11	LINEAR	0.XX	±0.1
Chr			0.XXX	±0.05	ECN
Appr			Product family		Spec ref
SUB MALE DW full power without contact				C01-8639-2315	Rev.
catalog no				CUSTOMER	sheet 3 of 4

5W5

8W8

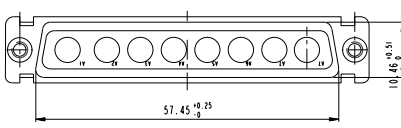
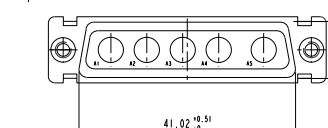
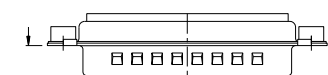
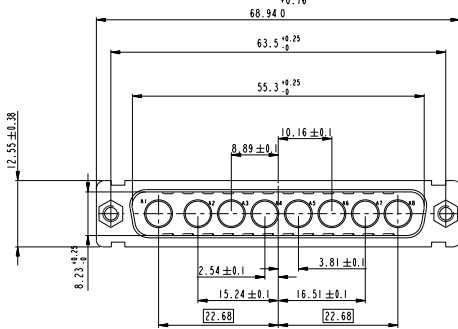
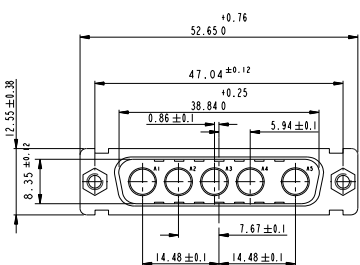

Copyright FCI

www.fciconnect.com		surface 150 1302	tolerance std 150 406 150 1101	projection TOLERANCES UNLESS OTHERWISE SPECIFIED	mm
Dr	M. PESSON	2005-10-11	ANGULAR	0.1	±0.3
Eng	P. LEGARE	2005-10-11	LINEAR	0.14	±0.1
Chr			0.12	±0.05	ECN
Appr			Product family		Spec ref
SUB MALE DW full power without contact				C01-8639-2315	Rev. E
catalog no				CUSTOMER	sheet 4 of 4