

# INSTRUMENTATION HANDLES



## CHOICE of BRASS or ALUMINUM - ROUND or OVAL

These instrumentation handles are manufactured in a wide variety of diameters, lengths, platings and internal thread sizes. They will enhance the look of quality products and equipment and provide the sturdiness needed for contemporary equipment.

### ROUND

- Available in: .156 (4.0), .187 (4.8), .250 (6.4), .312 (7.9), and .375 (9.5) diameters
- Mounting centers from 1.250 (31.8) to 6.437 (163.5)
- Internal threads 4-40, 6-32, 8-32 and 10-32
- Heights from .625 (15.9) to 1.750 (44.5)

#### MATERIAL:

**Brass:** ASTM-B16, Nickel Plate

**Aluminum:** QQ-A-200, Alloy 6061-T6, Black Anodized per MIL-A-8625

### OVAL

- Available in: .625 (15.9) × .281 (7.1) Oval
- Mounting centers from 4.000 (101.6) to 6.437 (163.5)
- Internal threads 10-32
- Heights from 1.375 (34.9) to 2.000 (50.8)

#### MATERIAL:

**Aluminum:** QQ-A-200, Alloy 6061-T6, Black Anodized per MIL-A-8625

## OVAL INSTRUMENTATION HANDLES

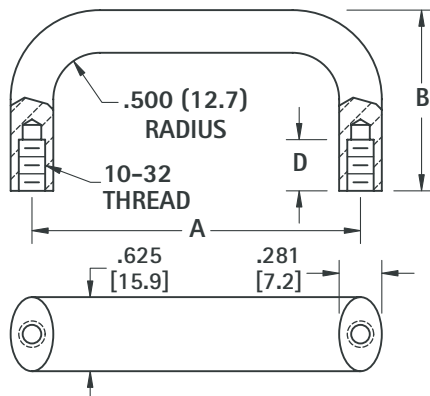

ALUMINUM CAT. NO.	A MTG. CTRS.	B HEIGHT	D DEPTH
7186	4.000 (101.6)	1.750 (44.5)	.500 (12.7)
544	4.000 (101.6)	2.000 (50.8)	
540	4.500 (114.3)	1.750 (44.5)	
545	4.500 (114.3)	2.000 (50.8)	
541	5.000 (127.0)	1.750 (44.5)	
546	5.000 (127.0)	2.000 (50.8)	
542	5.500 (139.7)	1.750 (44.5)	
547	5.500 (139.7)	2.000 (50.8)	.375 (9.5)
7187	6.000 (152.4)	1.375 (34.9)	
543	6.000 (152.4)	1.750 (44.5)	
548	6.000 (152.4)	2.000 (50.8)	
7188	6.437 (163.5)	1.750 (44.5)	

# ROUND INSTRUMENTATION HANDLES



**MATERIAL:**

**Brass:** ASTM-B16, Nickel Plate  
**Aluminum:** QQ-A-200, Alloy 6061-T6, Black Anodized per MIL-A-8625

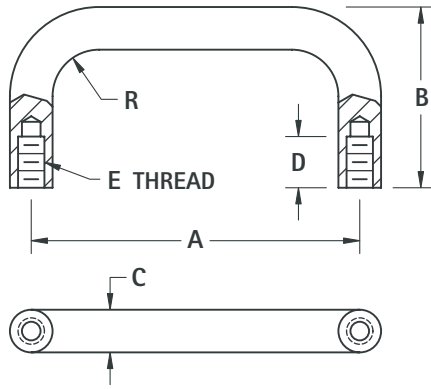

BRASS CAT. NO.	ALUMINUM CAT. NO.	A MTG. CTRS.	B HEIGHT	D DEPTH	E THREAD	R RADIUS	C DIAMETER
7140	7170	1.250 (31.8)	1.000 (25.4)				
7141	7171	2.000 (50.8)	1.000 (25.4)	.375 (9.5)	4-40	.156 (4.0)	<b>.156 (4.0)</b>
7142	7172	3.000 (76.2)	1.000 (25.4)				
9100	9110	1.250 (31.8)	.625 (15.9)				
9101	9111	1.500 (38.1)	.625 (15.9)				
9104	9114	1.500 (38.1)	.750 (19.1)	.156 (4.0)	4-40	.187 (4.7)	<b>.187 (4.7)</b>
9102	9112	1.750 (44.5)	.625 (15.9)				
9105	9115	1.750 (44.5)	.750 (19.1)				
9103	9113	2.000 (50.8)	.625 (15.9)				
9106	9116	1.250 (31.8)	1.000 (25.4)				
9107	9117	1.500 (38.1)	1.000 (25.4)	.250 (6.4)	6-32	.187 (4.7)	<b>.187 (4.7)</b>
9108	9118	2.000 (50.8)	1.000 (25.4)				
9109	9119	3.000 (76.2)	1.000 (25.4)				
7143	7173	3.000 (76.2)	1.500 (38.1)				
485	515	3.000 (76.2)	1.750 (44.5)				
480	510	3.500 (88.9)	1.500 (38.1)				
7144	7174	4.000 (101.6)	1.500 (38.1)				
486	516	4.000 (101.6)	1.750 (44.5)				
481	511	4.500 (114.3)	1.500 (38.1)	.562 (14.3)	8-32	.250 (6.4)	<b>.250 (6.4)</b>
487	517	4.500 (114.3)	1.750 (44.5)				
482	512	5.000 (127.0)	1.500 (38.1)				
488	518	5.000 (127.0)	1.750 (44.5)				
483	513	5.500 (139.7)	1.500 (38.1)				
484	514	6.000 (152.4)	1.500 (38.1)				
489	519	6.000 (152.4)	1.750 (44.5)				
7145	7175	3.000 (76.2)	1.500 (38.1)				
7146	7176	4.000 (101.6)	1.500 (38.1)				
493	523	4.000 (101.6)	1.750 (44.5)				
490	520	4.500 (114.3)	1.500 (38.1)	.562 (14.3)	10-32	.312 (7.9)	<b>.312 (7.9)</b>
494	524	4.500 (114.3)	1.750 (44.5)				
7147	7177	4.562 (115.9)	1.500 (38.1)				
491	521	5.000 (127.0)	1.500 (38.1)				
495	525	5.000 (127.0)	1.750 (44.5)				
492	522	5.500 (139.7)	1.500 (38.1)				
7148	7178	6.000 (152.4)	1.500 (38.1)				
496	526	6.000 (152.4)	1.750 (44.5)				
7149	7179	6.437 (163.5)	1.750 (44.5)				
7150	7180	4.000 (101.6)	1.375 (34.9)	.375 (9.5)	10-32	.375 (9.5)	<b>.375 (9.5)</b>
7151	7181	6.000 (152.4)	1.375 (34.9)				

# FERRULES

**FERRULES FOR ROUND HANDLES**

- To protect and support panel surface



**MATERIAL:**

**Brass:** ASTM-B16, Nickel Plate  
**Aluminum:** QQ-A-200, Alloy 6061-T6, Black Anodized per MIL-A-8625

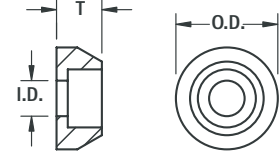

BRASS CAT. NO.	ALUMINUM CAT. NO.	FOR THREAD	FOR DIAMETER	O.D.	I.D.	T
7162	7192	4-40	.156 (4.0)	.250 (6.4)	.120 (3.0)	.125 (3.2)
9120	9122	4-40	.187 (4.7)	.312 (7.9)	.120 (3.0)	.125 (3.2)
9121	9123	6-32	.187 (4.7)	.312 (7.9)	.144 (3.7)	.125 (3.2)
7163	7193	8-32	.250 (6.4)	.375 (9.5)	.170 (4.3)	.187 (4.7)
7164	7194	10-32	.312 (7.9)	.562 (14.3)	.196 (5.0)	.250 (6.4)

# HANDLE MOUNTING SCREWS

- Phillips drive pan head machine screws

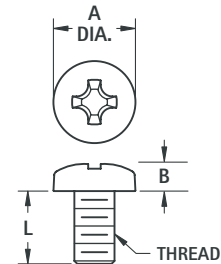

**MATERIAL:** Stainless Steel

CAT. NO.	L LENGTH	THREAD	A	B	DRIVER SIZE
9900	.250 (6.4)	4-40	.212 (5.4)	.065 (1.65)	1
9901	.375 (9.5)				
9902	.500 (12.7)				
9903	.250 (6.4)	6-32	.263 (6.7)	.092 (2.33)	2
9904	.375 (9.5)				
9905	.500 (12.7)				
9906	.375 (9.5)	8-32	.314 (8.0)	.110 (2.8)	2
9907	.500 (12.7)				
9908	.750 (19.1)				
9909	.375 (9.5)	10-32	.365 (9.3)	.128 (3.3)	2
9910	.500 (12.7)				
9911	.750 (19.1)				

## CUSTOM HANDLES

Keystone is fully integrated to meet your total design and production needs. Our specialty is manufacturing custom designs and modifications of standard items. Forward your CAD drawing or print to our Engineering Department for a quote on your specific production requirements.

INSTRUMENTATION HANDLES

Marking

THREAD

O.D.

I.D.

L

A

B

# HANDLES



This retractable handle is manufactured with black leather-like material and Nickel Plated steel hardware. Handle folds flat when not in use. Mounts with #6 screws (not supplied).

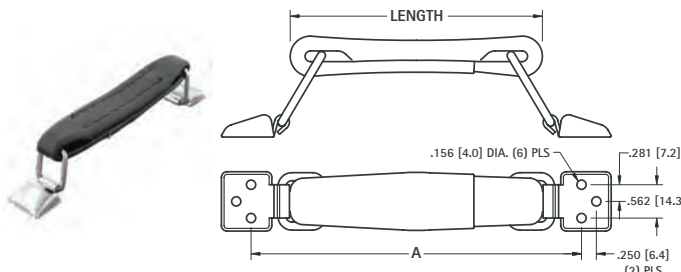

CAT. NO.	LENGTH	A
8351	4.500 (114.3)	6.000 (152.4)
8352	5.500 (139.7)	7.000 (177.8)
8353	6.000 (152.4)	7.500 (190.5)

**MATERIAL:**  
**Grip:** Leather like, Black  
**Hardware:** Steel, Nickel Plate

Folds flat on case when not in use. Mounts with rivets or #6 screws (not supplied).

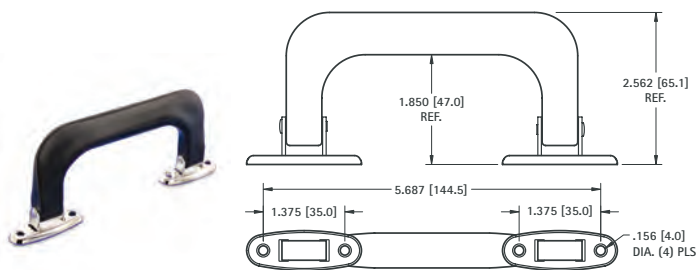

CAT. NO.	COLOR
8356	BLACK

**MATERIAL:**  
**Grip:** Polypropylene, Black  
**Post:** Steel, Nickel Plate  
**Pin:** Steel, Nickel Plate

Folds flat on case when not in use. Mounts with #10-24 hardware supplied.

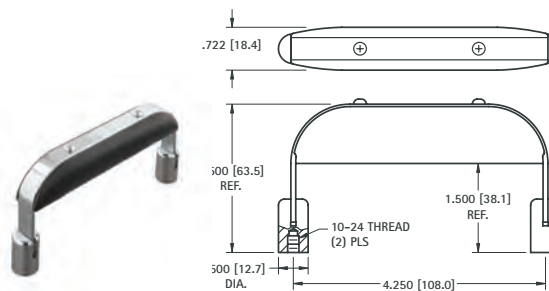

CAT. NO.	COLOR
8354	BLACK

**MATERIAL:**  
**Grip:** High Impact Styrene, Black  
**Rim:** Steel, Nickel Plate  
**Post:** Brass, Nickel Plate

## CONTEMPORARY HANDLES

**MATERIAL:** Zinc, Satin Brushed, Nickel Plate

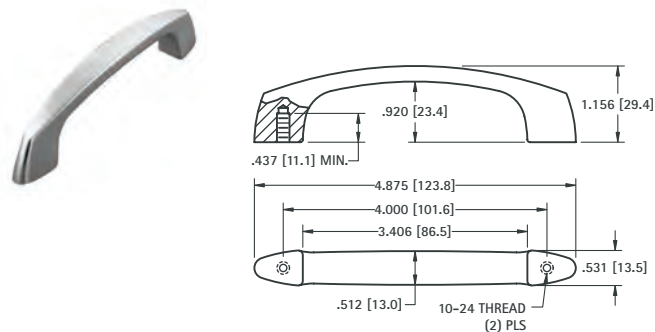

CAT. NO. 7197

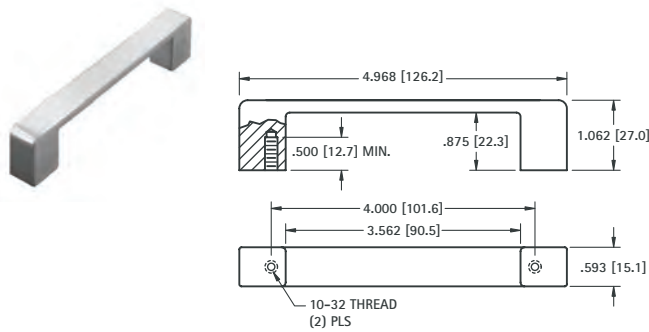

CAT. NO. 7196

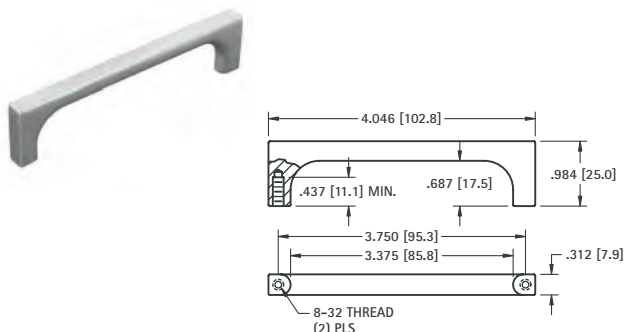

CAT. NO. 7199

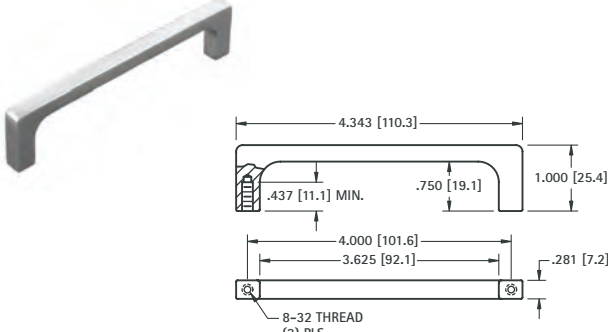

CAT. NO. 7198