

# STAR250 250K Pixel Radiation Hard CMOS Image Sensor

## Features

- 512 × 512 active pixels
- 25 μm pixel size
- 1 inch optical format
- Up to 30 frames per second (fps) at full resolution
- 10-bit analog-to-digital converter (ADC)
- Electronic shutter
- 8 MHz maximum data rate/master clock
- 3340 V.m<sup>2</sup>/W.s sensitivity
- 74 dB (5000:1) dynamic range
- 76 e<sup>-</sup> kTC noise
- 4750 e<sup>-</sup>/s at RT dark current
- 5V supply voltage
- Operating temperature range
  - 0 °C to +65 °C (STAR250)
  - -40 °C to +85 °C (STAR250BK7)
- Gamma total dose radiation tolerance:
  - Increase in average dark current < 1 nA/cm<sup>2</sup> after 3 MRad
  - Image operation with dark signal < 1 V/s after 10 Mrad demonstrated (Co60)
- Proton radiation tolerance:
  - 1% of pixels has an increase in dark current > 1 nA/cm<sup>2</sup> after 3\*10<sup>10</sup> protons at 11.7 MeV
- SEL threshold > 80 MeV cm<sup>3</sup> mg<sup>-1</sup>
- Mono color filter array
- 84-pin JLCC package
- Less than 350 mW power consumption

## Applications

- Satellites
- Spacecraft monitoring
- Nuclear inspection

## Overview

The STAR250 sensor is a CMOS active pixel sensor designed for application in optical inter-satellite link beam trackers. The STAR250 is part of broader range of applications including space borne systems such as sun sensing and star tracking. It features 512 × 512 pixels on a 25 μm pitch, on chip fixed pattern noise (FPN) correction, a programmable gain amplifier, and a 10-bit ADC. Flexible operating (multiple windowing, subsampling) is possible by direct addressable X and Y registers.

The sensor has an outstanding radiation tolerance that is observed using proprietary technology modifications and design techniques. Two versions of the sensors are available, STAR250 and STAR250BK7. STAR250 has a quartz glass lid and air in the cavity. The STAR250BK7 has a BK7G18 glass lid with anti reflective coating. The cavity is filled with N<sub>2</sub> increasing the temperature operating range.

**Figure 1. Star250 Photograph**

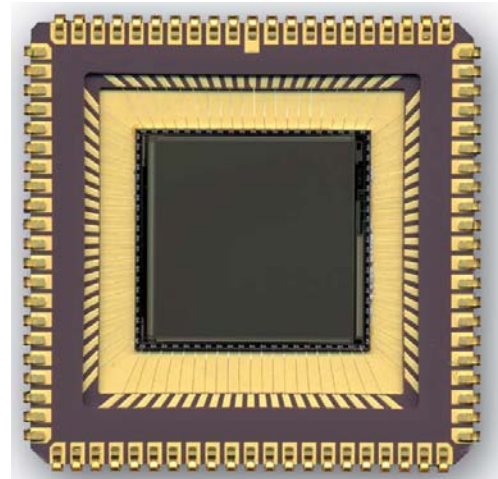

## Ordering Information

Marketing Part Number	Description	Package
CYIS1SM0250AA-HHC	Mono with BK7G18 glass	84-pin JLCC
CYIS1SM0250AA-HHCS	Mono with BK7G18 glass, space qualified	
CYIS1SM0250AA-WWC	Mono wafer	Wafer Sales (production)

Refer [Ordering Code Definition](#) on page 20 for more information.

**Contents**

<b>Features</b> .....	<b>1</b>	<b>Pinlist</b> .....	<b>15</b>
<b>Applications</b> .....	<b>1</b>	<b>Package</b> .....	<b>18</b>
<b>Overview</b> .....	<b>1</b>	Package with Glass .....	18
<b>Ordering Information</b> .....	<b>1</b>	Die Alignment .....	19
<b>Specifications</b> .....	<b>3</b>	Window Specifications .....	20
Electrical Specifications .....	6	Ordering Code Definition .....	20
<b>Sensor Architecture</b> .....	<b>9</b>	<b>Soldering and Handling</b> .....	<b>21</b>
Pixel Structure .....	9	<b>Handling Precautions</b> .....	<b>21</b>
Shift Registers .....	10	Limited Warranty .....	21
Column Amplifiers .....	10	RoHS (Pb-free) Compliance .....	21
Electronic Shutter .....	10	Evaluation Kit .....	21
Programmable Gain Amplifier .....	11	<b>Acronyms</b> .....	<b>22</b>
Analog-to-Digital Converter .....	11	<b>Document History Page</b> .....	<b>23</b>
<b>Timing and Readout of Image Sensor</b> .....	<b>11</b>	<b>Sales, Solutions, and Legal Information</b> .....	<b>23</b>
Image Readout Procedure .....	11	Worldwide Sales and Design Support .....	23
Loading the X and Y Start Positions .....	13		
Other Signals .....	14		

## Specifications

**Table 1. General Specifications**

Parameter	Specification	Remarks
Pixel architecture	3 transistor active pixel 4 diodes per pixel	Radiation-tolerant pixel design 4 photodiodes for improved MTF
Pixel size	25 × 25 μm <sup>2</sup>	
Resolution	512 × 512 pixels	
Pixel rate	8 Mps	
Shutter type	Electronic	Integration time is variable, steps equal to the row readout time
Frame rate	29 full frames/second	
Extended dynamic range	Double slope	
Programmable gain	Programmable between x1, x2, x4, x8	Selectable through pins G0 and G1
Supply voltage V <sub>DD</sub>	5 V	
Operational temperature range	0 °C to +65 °C	STAR250 (quartz glass lid, air in cavity)
	-40 °C to +85 °C	STAR250BK7 (BK7G18 glass lid, N <sub>2</sub> in cavity)
Package	84-pin JLCC	

**Table 2. Electro-optical Specifications**

Parameter	Specification (Typical)	Comment
Detector technology	CMOS active pixel sensor	
Pixel structure	3-transistor active pixel 4 diodes per pixel	Radiation-tolerant pixel design 4 photodiodes for improved MTF
Photodiode	High fill factor photodiode	
Sensitive area format	512 by 512 pixels	
Pixel size	25 μm <sup>2</sup> × 25 μm <sup>2</sup>	
Spectral range	200 nm to 1000 nm	See <a href="#">Figure 2</a> and <a href="#">Figure 3</a>
Quantum efficiency x fill factor	Maximum 35%	Above 20% between 450 nm and 750 nm (Metal FillFactor (MFF) is 63%)
Full well capacity	311K electrons	When output amplifier gain = 1
Linear range within +1%	128K electrons	When output amplifier gain = 1
Output signal swing	1.68 V	When output amplifier gain = 1
Conversion gain	5.7 μV/e <sup>-</sup>	When output amplifier gain = 1 near dark
Temporal noise	76 e <sup>-</sup>	Dominated by kTC
Dynamic range	74 dB (5000:1)	At the analog output
FPN	1 < 0.1% of full well (typical)	Measured local, on central image area 50% of pixels in the dark
PRNU (photo response nonuniformity)	Local: 1 = 0.39% of response Global: 1 = 1.3% of response	Measured in central image area 50% of pixels, at Qsat/2
Average dark current signal	4750 e <sup>-</sup> /s	At RT
DSNU (dark signal nonuniformity)	3805 e <sup>-</sup> /s RMS	At RT, scale linearly with integration time
MTF	Horizontal: 0.36 Vertical: 0.39	at 600 nm.

**Table 2. Electro-optical Specifications** (continued)

Parameter	Specification (Typical)	Comment
Optical cross talk	5% to nearest neighbor if central pixel is homogeneously illuminated	
Antiblooming capacity	x 1000 to x 100 000	
Output amplifier gain	1, 2, 4, or 8	Controlled by two bits
Windowing	X and Y 9-bit programmable shift registers	Indicate upper left pixel of each window
Electronic shutter range	1: 512	Integration time is variable in time steps equal to the row readout time
ADC	10-bit	
ADC linearity	±3.5 counts	INL
Missing codes	none	
ADC setup time	310 ns	To reach 99% of final value
ADC delay time	125 ns	
Power dissipation	< 350 mW	Average at 8 MHz pixel rate

*Spectral Response Curve*

**Figure 2. Spectral Response Curve**

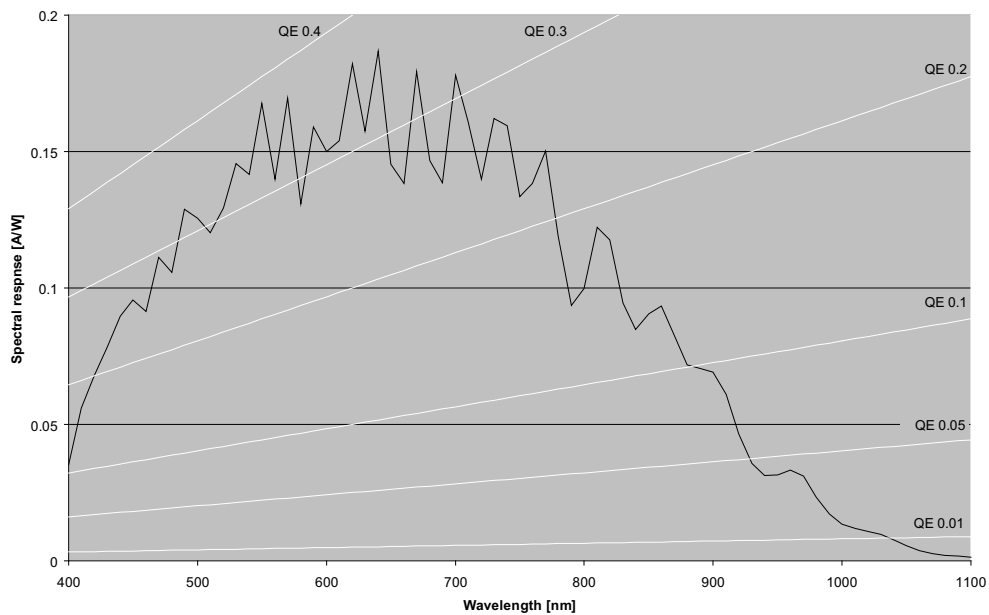
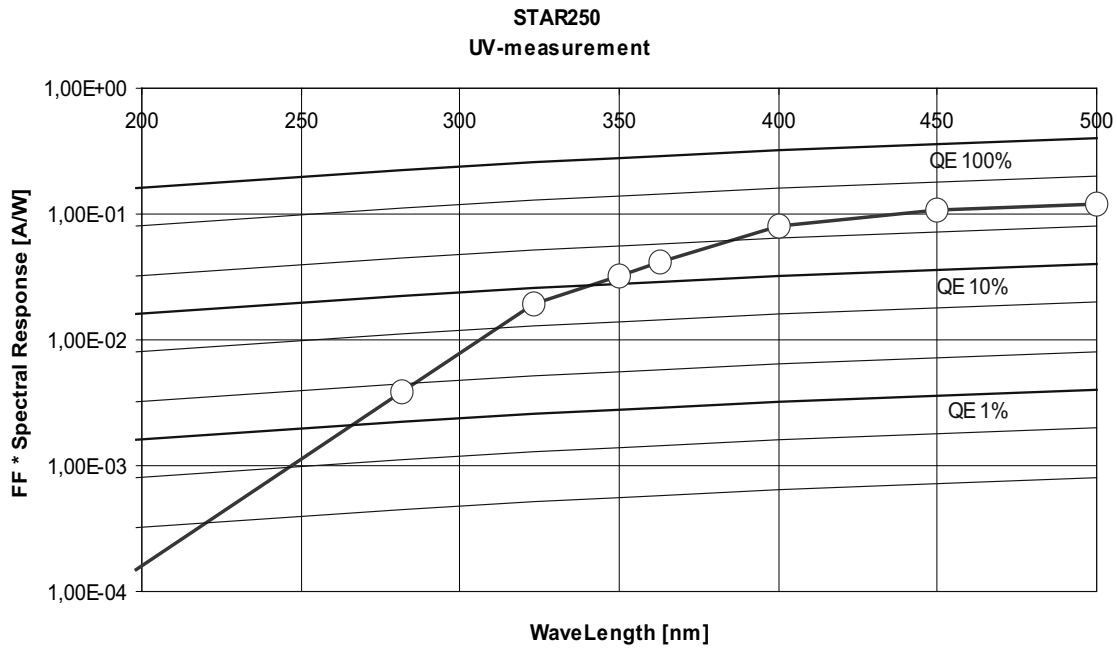
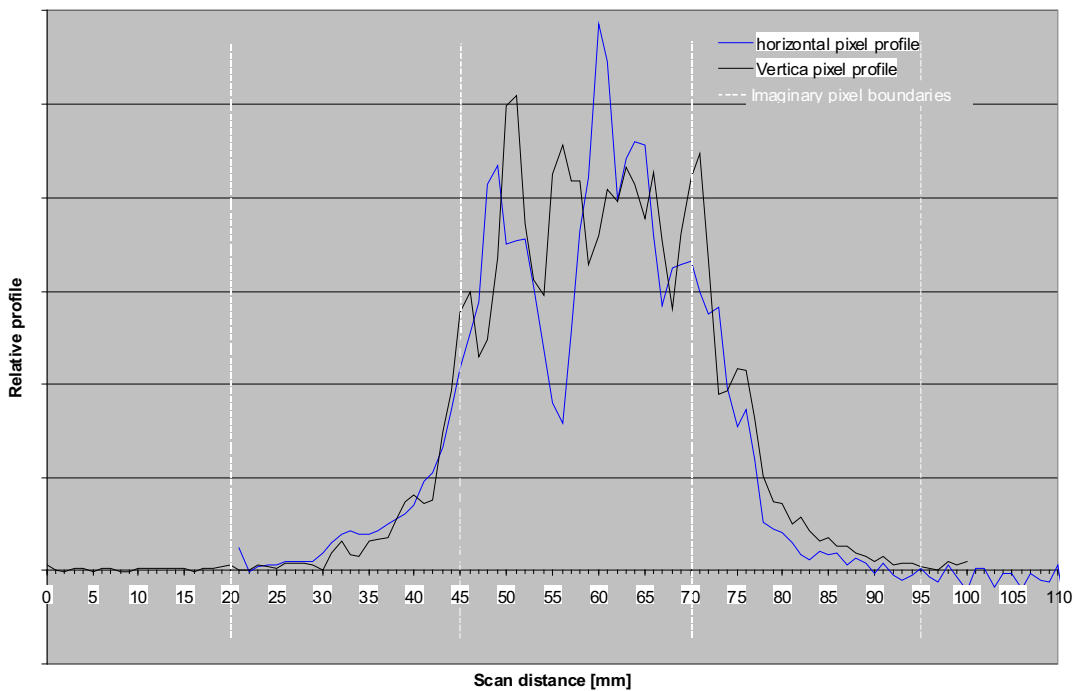

Figure 3. UV Region Spectral Response Curve



Pixel Profile

Figure 4. Pixel Profile



The pixel profile is measured using the 'knife edge' method: the image of a target containing a black to white transition is scanned over a certain pixel with subpixel resolution steps. The sensor settings and illumination conditions are adjusted such that the transition covers 50% of the output range. The scan is performed both horizontal and vertical.

**Electrical Specifications**

*Absolute Maximum Ratings*

Absolute ratings are those values beyond which damage to the device may occur.

**Table 3. Absolute Maximum Ratings STAR250**

Characteristics	Limits		Units	Remarks
	Min	Max		
Any supply voltage	-0.5	+7	V	
Voltage on any input terminal	-0.5	V <sub>DD</sub> + 0.5	V	
Operating temperature	0	+60	°C	
Storage temperature	-10	+60	°C	
Sensor soldering temperature	NA	125	°C	Hand soldering only. The sensor's temperature during soldering should not exceed this limit.

**Table 4. Absolute Maximum Ratings STAR250BK7**

Characteristics	Limits		Units	Remarks
	Min	Max		
Any supply voltage	-0.5	+7	V	
Voltage on any input terminal	-0.5	V <sub>DD</sub> + 0.5	V	
Operating temperature	-40	+85	°C	
Storage temperature	-40	+85	°C	
	-40	+120	°C	Maximum 1 hour
Sensor soldering temperature	NA	125	°C	Hand soldering only. The sensor's temperature during soldering should not exceed this limit.

**Table 5. Radiation Tolerance**

Parameter	Criterion	Qualification level
Gamma total dose radiation tolerance	Increase in average dark current < 1 nA/cm <sup>2</sup> after 3 MRad	See <a href="#">Figure 5</a>
	Image operation with dark signal < 1V/s	10 Mrad demonstrated (Co60)
	Single (test) pixel operation with dark signal < 1V/s	24 Mrad demonstrated (Co60)
Proton radiation tolerance	1% of pixels has an increase in dark current > 1 nA/cm <sup>2</sup> after 3 × 10 <sup>10</sup> protons at 11.7 MeV	See <a href="#">Figure 5</a>
SEL threshold	> 80 MeV cm <sup>3</sup> mg <sup>-1</sup>	To be confirmed

Figure 5 shows the increase in dark current under total dose irradiation. This curve is measured when the radiation is at high dose rate. Annealing results in a significant dark current decrease.

Figure 5. Dark Current Increase

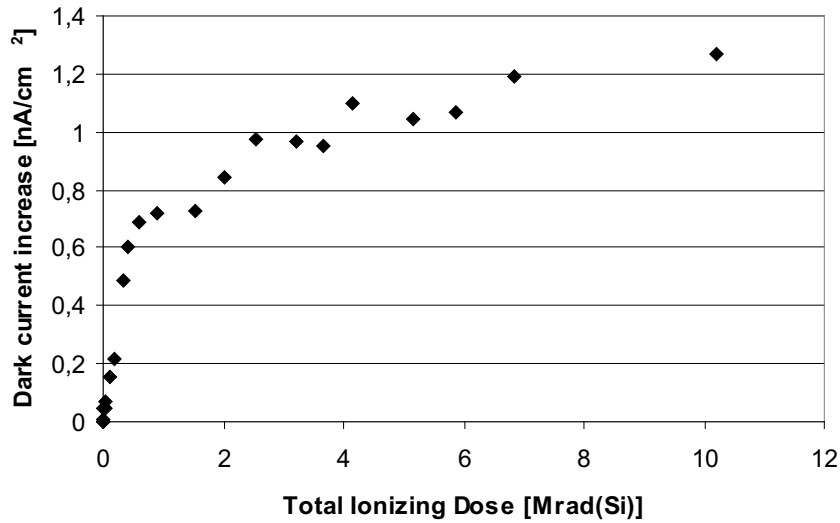
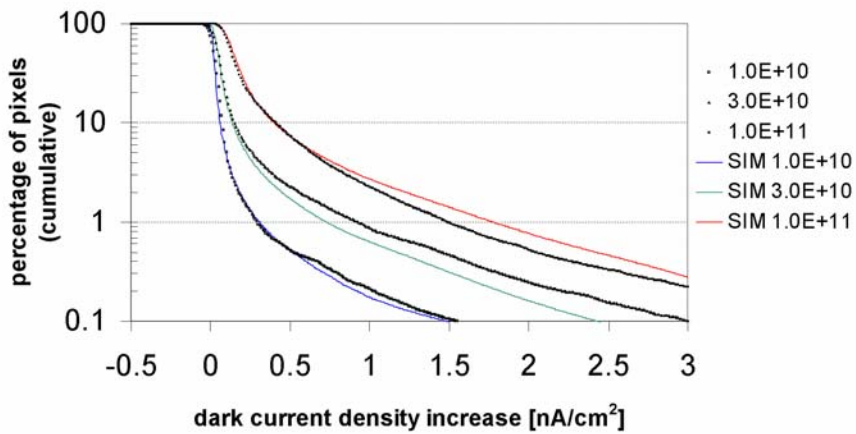

Figure 6 shows the percentage of pixels with a dark current increase under 11.7 MeV radiation with protons.

Figure 6. Percentage of Pixels with Dark Current Increase



*DC Operating Conditions*
**Table 6. DC Specifications**

Symbol	Parameter <sup>[1,2,3]</sup>	Min	Typ	Max	Units
V <sub>DD_ANA</sub>	Analog supply voltage to imager part	–	5	–	V
V <sub>DD_DIG</sub>	Digital supply voltage to imager part	–	5	–	V
V <sub>DD_ADC_ANA</sub>	Analog supply voltage to ADC	–	5	–	V
V <sub>DD_ADC_DIG</sub>	Digital supply voltage to ADC	–	5	–	V
V <sub>DD_ADC_DIG_3.3/5</sub>	Supply voltage of ADC output stage	–	3.3 to 5	–	V
V <sub>IH</sub>	Logical '1' input voltage	2.3	–	V <sub>DD</sub>	V
V <sub>IL</sub>	Logical '0' input voltage	0	–	1	V
V <sub>OH</sub>	Logical '1' output voltage	4.25	4.5	–	V
V <sub>OL</sub>	Logical '0' output voltage	–	0.1	1	V
V <sub>DD_PIX</sub>	Pixel array power supply (default 5 V, the device is then in 'soft reset'. To avoid the image lag associated with soft reset, reduce this voltage to 3–3.5 V 'hard reset')	–	5	–	V
V <sub>DD_RESL</sub>	Reset power supply	–	5	–	V

**Notes**

1. All parameters are characterized for DC conditions after establishing thermal equilibrium.
2. Unused inputs must always be tied to an appropriate logic level, for example, either VDD or GND.
3. This device contains circuitry to protect the inputs against damage due to high static voltages or electric fields. Take normal precautions to avoid applying any voltages higher than the maximum rated voltages to this high impedance circuit.



## Sensor Architecture

Figure 7. STAR250 Schematic

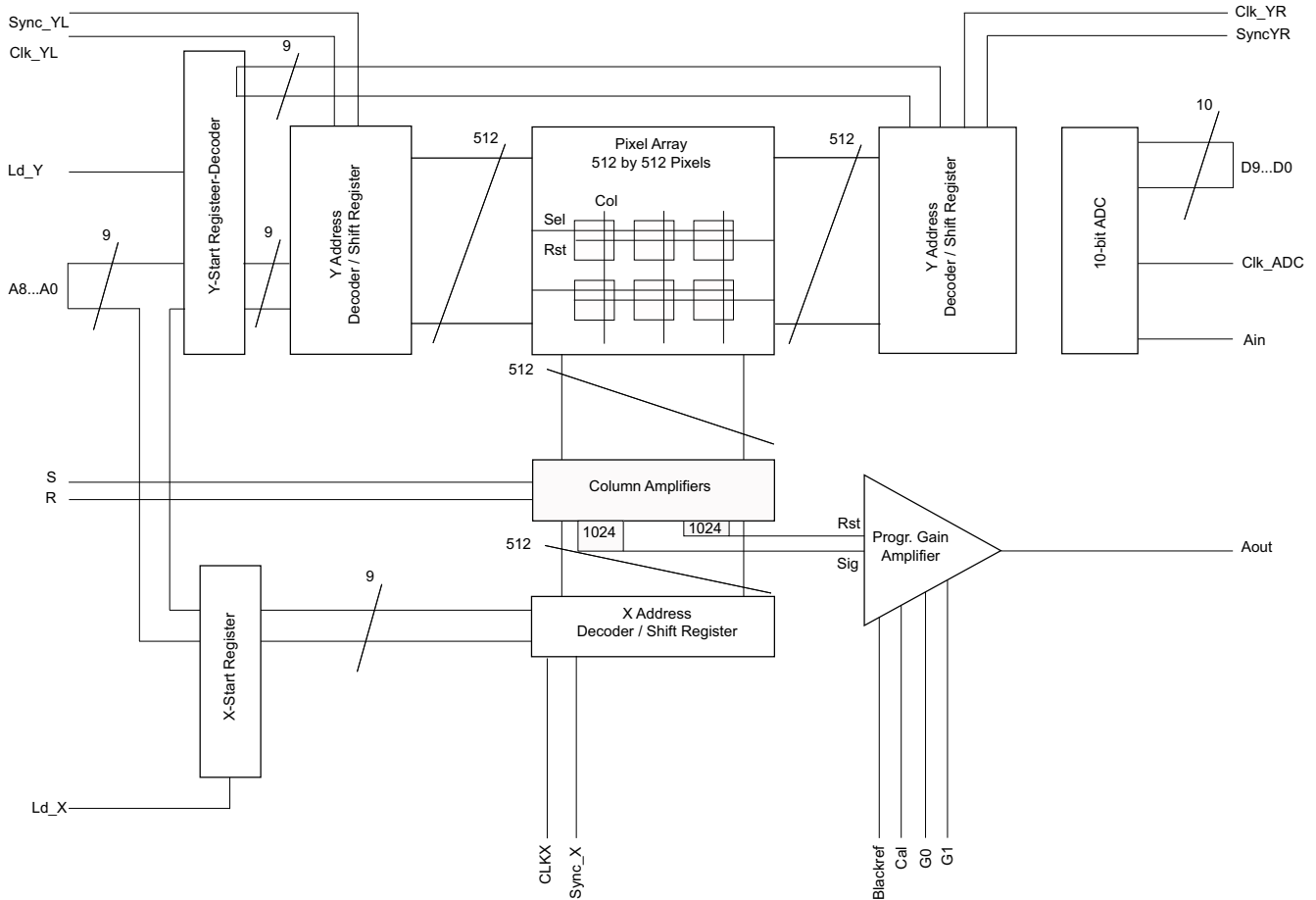

The base line of the STAR250 sensor design consists of an imager with a 512 by 512 array of active pixels at 25  $\mu\text{m}$  pitch. The detector contains on-chip correction for FPN in the column amplifiers, a programmable gain output amplifier, and a 10-bit ADC. Through additional preset registers, the start position of a window can be programmed to enable fast read out of only part of the detector array.

### Pixel Structure

The image sensor consists of several building blocks as outlined in Figure 7. The central element is a 512 by 512 pixel array with square pixels at 25  $\mu\text{m}$  pitch. Unlike classical designs, the pixels of this sensor contain four photodiodes. This configuration enhances the MTF and reduces the PRNU. Figure 8 shows an electrical diagram of the pixel structure. The four photodiodes are connected in parallel to the reset transistor (T1). Transistor T2 converts the charge, collected on the photo diode node, to a voltage signal that is connected to the column bus by T3. The reset and read entrance of the pixel are connected to one of the Y shift registers.

Figure 8. STAR250 Pixel Structure

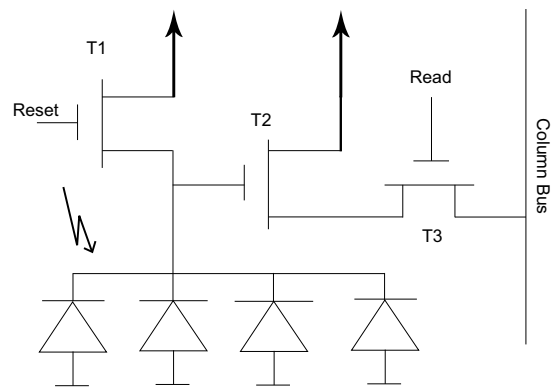

### Shift Registers

The shift registers are located next to the pixel array and contain equal number of outputs and pixel array rows. They are designed as "1-hot" registers, (YL and YR shift register) each allowing selection of one row of pixels at a time. A clock pulse moves the pointer one position down the register resulting in the selection of every individual row for either reset or readout. The spatial offset between the two selected rows determines the integration time. A synchronization pulse to the shift registers loads the value from a preset register into the shift register forcing the pointer to a predetermined position. Windowing in the vertical (Y) direction is achieved by presetting the registers to a row that is not the first row and by clocking out only the required number of rows.

### Column Amplifiers

All outputs from the pixels in a column are connected in parallel to a column amplifier. This amplifier samples the output voltage and the reset level of the pixel whose row is selected at that moment and presents these voltage levels to the output amplifier. As a result, the pixels are always reset immediately after readout as part of the sample procedure and the maximum integration time of a pixel is the time between two read cycles.

### Electronic Shutter

In a linescan integrating imager with electronic shutter, there are two continuous processes of image gathering.

The first process resets lines in a progressive scan. At line reset, all the pixels in a line are drained from any photo charges collected since their last reset or readout. After reset, a new exposure cycle starts for that particular line.

The second process is the actual readout, which also happens in an equally fast linewise progressive scan.

During readout, the photo charges collected since the previous reset are converted into an output voltage. This is then passed on pixel by pixel to the imager's pixel serial output and ADC. Readout is destructive, meaning the accumulation of charges from successive exposure phases is not possible in the present architecture.

The STAR250 has two Y shift registers; YL and YR. One is used to read out a line (YL) and the other is used to reset a line (YR). The integration time is equal to the time between the last reset and readout of that line, see Figure 9. The integration time is calculated as follows:

Integration time = (Nr. Lines × (RBT + pixel period × Nr. Pixels)) with:

- Nr. Lines: Number of lines between readout and reset (Y).
- Nr. Pixels: Number of pixels read out each line (X).
- RBT: Row Blanking Time = 3.2 μs (typical).
- Pixel period: 1/8 MHz = 125 ns (typical).

Figure 9. Electronic Shutter

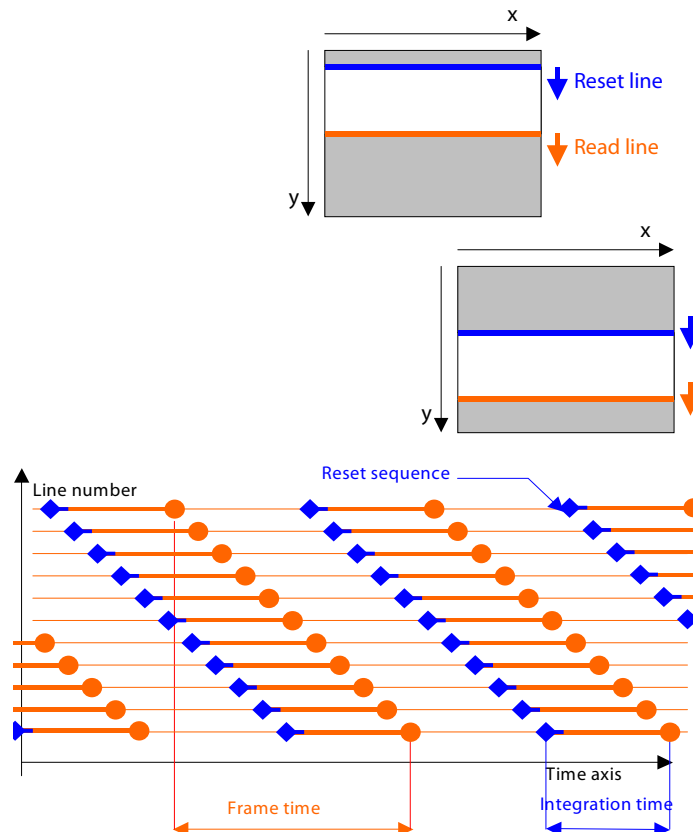

### Programmable Gain Amplifier

The signal from the column amplifiers is fed to an output amplifier with four presettable gains (adjustable with pins G0 and G1). The offset correction of this amplifier is done through a black reference procedure. The signal from the output amplifier is externally available on the analog output terminator of the device.

### Analog-to-Digital Converter

The on-chip 10-bit ADC is electrically separated from the other circuits of the device. The ADC conversion range is set by the voltages on VLOW\_ADC (pin 47) and VHIGHigh\_ADC (pin 70). Make voltages on these pins equal to about 2 V on VLOW\_ADC and 4 V on VHIGHigh\_ADC. The voltages are set by connecting VLOW with 1.2 kΩ to GND and VHIGHigh\_ADC with 560 Ω to V<sub>DD</sub>. This way, a resistor ladder is created as shown in Figure 10.

Figure 10. ADC Resistor Ladder

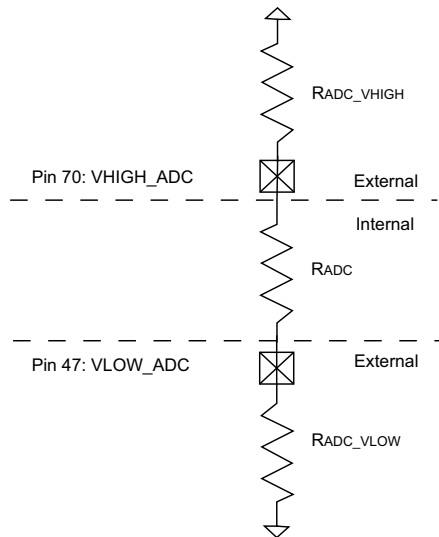

The internal ADC resistance varies according to temperature. The resistance value increases approximately 4.4 Ω/°C with increasing temperature. If the ADC range is set externally with resistors, the conversion range may vary with temperature. This effect is cancelled out by not making use of resistors but directly applying voltages on VLOW\_ADC and VHIGHigh\_ADC.

## Timing and Readout of Image Sensor

### Image Readout Procedure

A preamble or initialization phase is irrelevant. The sensor is read out continuously. The first frame is generally saturated and useless because there is no preceding reset of each pixel.

#### Image Readout

In an infinite uninterrupted loop, follow these steps for every line:

1. Synchronize the read (YL) and/or reset (YR) registers:
  - SYNC\_YL - to reinitiate the readout sequence to row position Y1
  - SYNC\_YR - to reinitiate the reset pointer to row position Y1

For all other lines do not pulse one of these SYNC\_Y signals.

2. Operate the double sampling column amplifiers with two RESETs. Apply one to reset the line that is currently selected to produce the reset reference level for the double sampling column amplifiers. Apply the other reset to another line depending on the required integration time reduction.
3. Perform a line readout:
  - Reset the X read address shift register to the value in its shadow register (X1).
  - Perform a pixel readout operation, operating the track/hold and the ADC.
  - Shift the X read address shift register one position further.
  - Shift the Y read and reset address shift registers one position further. If either of Y read or reset address shift register comes to the end of the pixel array (or the ROI), wrap it around to the start position by pulsing SYNC\_YL.

#### Readout Timing

The actual line readout process starts with addressing the line to read. This is done either by initializing the YL pointer with a new value or by shifting it one position beyond its previous value. (Addressing the line has reset, YR is done in an analogous fashion). During the "blanking time", after the new line is addressed on the sensor, the built-in column-parallel double sampling amplifiers are operated. This renders offset-corrected values of the line under readout.

After the blanking time, the pixels of the row addressed by YL are read by multiplexing all the pixels one by one to the serial output chain. The pixel is selected by the X pointer and that pointer is either initialized with a new value or an increment of the previous position.

The time between row resets and their corresponding row readouts is the effective exposure time (or integration time). This time is proportional to the number of lines (DelayLines) between the line currently under reset and the line currently under readout: DelayLines = (YR - YL+1). This time is also equal to the delay between the SYNC\_YR pulse and the subsequent SYNC\_YL.

The effective integration time tint is calculated as delaylines x line time. The line time is a function of four terms: the time to output the desired number of pixels in the line (Wframe) and the overhead ("blanking") time needed to select a new line and perform the double sampling and reset operations.

Figure 11. Basic Readout Timing

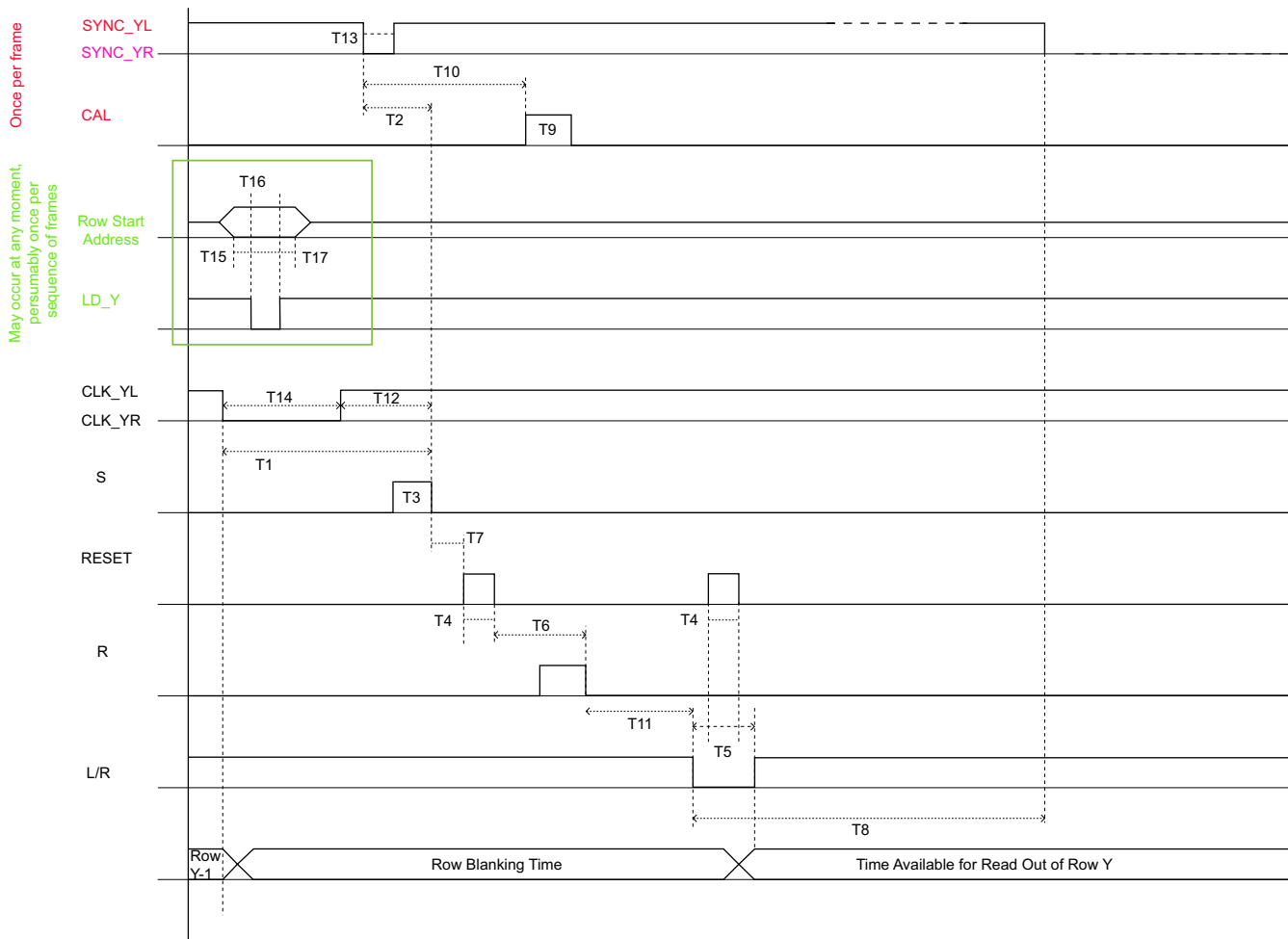

SYNC\_YR is not identical to SYNC\_YL. SYNC\_YR is used in electronic shutter operation. The CLK\_YR is driven identical to CLK\_YL, but the SYNC\_YR pulse leads the SYNC\_YL pulse by a certain number of rows. This lead time is the effective integration (electronic shutter ~) time. Relative to the row timing, both SYNC pulses are given at the same time position, once for each frame, but during different rows.

SYNC\_YL is pulsed when the first row is read out and SYNC\_YR is pulsed for the electronic shutter to start for this first row. CAL is pulsed on the first row too, 2  $\mu$ s later than SYNC\_YL.

The minimal idle time is 1.4  $\mu$ s (before starting reading pixels). However, do not read out pixels during the complete row initialization process (in between the rising edge on S and the falling edge on L/R). In this case, the total idle time is minimal. This timing assumes that the Y start register was loaded in advance, which can occur at any time but before the pulse on SYNC\_YL or SYNC\_YR.

**Table 7. Readout Timing Specifications**

Symbol	Min	Typ	Description
T1	1.8 $\mu$ s	–	Delay between selection of new row by falling edge on CLK_YL and falling edge on S. Minimal value. Normally, CLK_YR is low already at the end of the previous sequence.
T2	1.8 $\mu$ s	–	Delay between selection of new a row by SYNC_YL and falling edge on S.
T3	0.4 $\mu$ s	–	Duration of S and R pulse.
T4	0.1 $\mu$ s	–	Duration of RESET pulse.
T5	T4 + 40 ns	0.3 $\mu$ s	L/R pulse must overlap second RESET pulse at both sides.
T6	0.8 $\mu$ s	–	Delay between falling edge on RESET and falling edge on R.
T7	20 ns	0.1 $\mu$ s	Delay between falling edge on S and rising edge on RESET.
T8	0	1 $\mu$ s	Delay between falling edge on L/R and falling edge on CLK_Y.
T9	100 ns	1 $\mu$ s	Duration of cal pulse. The CAL pulse is given once each frame.
T10	0	2 $\mu$ s	Delay between falling edge of SYNC_YL and rising edge of CAL pulse.
T11	40 ns	0.1 $\mu$ s	Delay between falling edge on R and rising edge on L/R.
T12	0.1 $\mu$ s	1 $\mu$ s	Delay between rising edge of CLK_Y and falling edge on S.
T13	–	0.5 $\mu$ s	Pulse width SYNC_YL/YR.
T14	–	0.5 $\mu$ s	Pulse width CLK_YL/YR.
T15	10 ns	–	Address setup time.
T16	20 ns	–	Load X/Y start register value.
T17	10 ns	–	Address stable after load.
T18	10 ns	–	
T19	20 ns	–	SYNC_X pulse width. SYNC_X while CLK_X is high.
T20	10 ns	–	
T21	–	40 ns	Analog output is stable during CLK_X low.
T22	–	40 ns	CLK_X pulse width: During this clock phase the analog output ramps to the next pixel level.
T23	–	125 ns	ADC digital output stable after falling edge of CLK_ADC.

### Loading the X and Y Start Positions

The start positions (start addresses) for region of interest (ROI) are preloaded in the X or Y start register. They become effective by the application of the SYNC\_X, SYNC\_YL and/or SYNC\_YR. The start X or Y address must be applied to their common address bus and the corresponding LD\_X or LD\_Y pin must be pulsed.

On each falling edge of CLK\_X, a new pixel of the same row (line) is accessed. The output stage is in hold when CLK\_X is low and starts generating a new output after a rising edge on CLK\_X.

The following timing constraints apply:

Load the X or Y start addresses in advance, before the X or Y shift registers are preset by a SYNC pulse. However, if necessary, they can be loaded just before the SYNC\_X or SYNC\_Y pulse as shown in [Figure 12](#).

For example, the X start register can be loaded during the row idle time. The Y start register can be loaded during readout of the last row of the previous frame.

If the X or Y start address does not change for later frames, it does not need to be reloaded in the register.

Figure 12. Timing to Load X and Y Registers

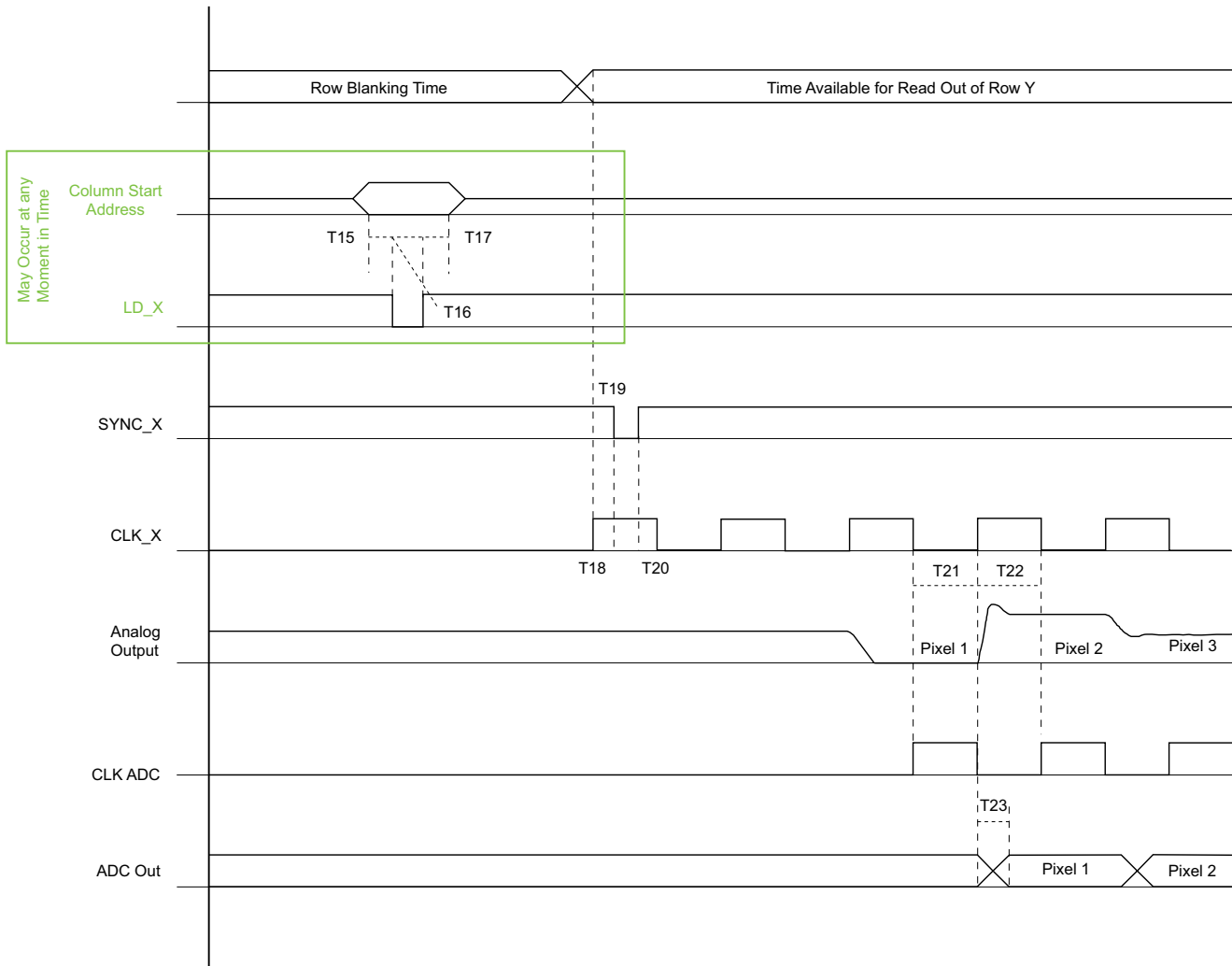

**Other Signals**

Tie SELECT signal to  $V_{DD}$  for normal operation. This signal is added for diagnostic reasons and inhibits the pixel array operation when held low.

The CAL signal sets the output amplifier DC offset level. When this signal is active (high) the pixel array is internally disconnected from the output amplifier, its gain is set to unity and its input signal is connected to the BLACK\_REF input. Perform this action at least once for each frame.

EOS\_X, EOS\_YL, and EOS\_YR produce a pulse when the respective shift register comes at its end. These outputs are used mainly during testing to verify proper operation of the shift registers.

TESTDIODE and TESTPIXEL\_ARRAY are connections to optical test structures that are used for electro optical evaluation. TESTDIODE is a plain photodiode with an area of 14x5 pixels. TESTPIXEL\_ARRAY is an array (14x5) of pixels where the photodiodes are connected in parallel. These structures measure the photocurrent of the diodes directly.

TESTPIXEL\_RESET and TESTPIXEL-OUT are connections to a single pixel that are used for testing.

## Pinlist

**Table 8. Power Supply Connections**

Pin	Pin Name	Pin Description
10	V <sub>DD_ANA</sub>	Analog power supply 5 V
11	V <sub>DD_DIG</sub>	Digital power supply 5 V
31	V <sub>DD_AMP</sub>	Power supply of output amplifier 5 V
33	V <sub>DD_DIG</sub>	Digital power supply 5 V
34	V <sub>DD_ANA</sub>	Analog power supply 5 V
49	V <sub>DD_RESR</sub>	Reset power supply 5 V
50	V <sub>DD_DIG</sub>	Digital power supply 5 V
53	V <sub>DD_ADC_ANA</sub>	ADC analog power supply 5 V
66	V <sub>DD_ADC_ANA</sub>	ADC analog power supply 5 V
67	V <sub>DD_ADC_DIG</sub>	ADC digital power supply 5 V
69	V <sub>DD_ADC_DIG_3.3/5</sub>	ADC 3.3 V power supply for digital output of ADC For interface with 5 V external system: connect to V <sub>DD_ADC_DIG</sub> For interface with 3.3 V external system: connect to 3.3 V power supply
52 76	V <sub>DD_PIX</sub>	Pixel array power supply [default: 5 V, the device is then in 'soft reset'. To avoid the image lag associated with soft reset, reduce this voltage to 3...3.5 V 'hard reset']
78	V <sub>DD_DIG</sub>	Digital power supply 5 V
79	V <sub>DD_RESL</sub>	Reset power supply 5 V

**Table 9. Ground Connections**

Pin	Pin Name	Pin Description
9	GND_ANA	Analog ground
12	GND_DIG	Digital ground
30	GND_AMP	Ground of output amplifier
32	GND_DIG	Digital ground
35	GND_ANA	Analog ground
51	GND_DIG	Digital ground
54	GND_ADC_ANA	ADC analog ground
65	GND_ADC_ANA	ADC analog ground
68	GND_ADC_DIG	ADC digital ground
77	GND_DIG	Digital ground

**Table 10. Digital Input Signals**

Pin	Pin Name	Pin Description
1	S	Control signal for column amplifier Apply pulse pattern; see <a href="#">Figure 11</a>
2	R	Control signal for column amplifier Apply pulse pattern; see <a href="#">Figure 11</a>
3	RESET	Resets row indicated by left/right shift register high active (1= reset row) Apply pulse pattern; see <a href="#">Figure 11</a>
4	SELECT	Selects row indicated by left/right shift register high active (1=select row) Apply 5 V DC for normal operation
5	L/R	Use left or right shift register for SELECT and RESET 1 = left/0 = right; see <a href="#">Figure 11</a>

**Table 10. Digital Input Signals** (continued)

Pin	Pin Name	Pin Description
6	A0	Start address for X and Y pointers (LSB)
7	A1	Start address for X and Y pointers
8	A2	Start address for X and Y pointers
13	A3	Start address for X and Y pointers
14	A4	Start address for X and Y pointers
15	A5	Start address for X and Y pointers
16	A6	Start address for X and Y pointers
17	A7	Start address for X and Y pointers
18	A8	Start address for X and Y pointers (MSB)
19	LD_Y	Latch address (A0...A8) to Y start register (0 = track, 1 = hold)
20	LD_X	Latch address (A0...A8) to X start register(0 = track, 1 = hold)
21	CLK_YL	Clock YL shift register (shifts on falling edge)
22	SYNC_YL	Sets YL shift register to location preloaded in Y start register Low active (0=sync) Apply SYNC_YL when CLK_YL is high
24	CLK_X	Clock X shift register (output valid and s when CLK_X is low)
25	SYNC_X	Sets X shift register to location preloaded in X start register Low active (0=sync) Apply SYNC_X when CLK_X is high After SYNC_X, apply falling edge on CLK_X, and rising edge on CLK_X
27	CLK_YR	Clock YR shift register (shifts on falling edge)
28	SYNC_YR	Sets YR shift register to location preloaded in Y start register Low active (0=sync) Apply SYNC_YR when CLK_YR is high
36	CAL	Initialize output amplifier Output amplifier will output BLACKREF in unity gain mode when CAL is high (1) Apply pulse pattern (one pulse per frame); see <a href="#">Figure 11</a>
37	G0	Select output amplifier gain value: G0 = LSB; G1 = MSB 00 = unity gain; 01 = x2; 10 = x4; 11 = x8
38	G1	idem
71	CLK_ADC	ADC clock ADC converts on falling edge
75	BITINVERT	1 = invert output bits 0 = no inversion of output bits
80	TRI_ADC	Tristate control of digital ADC outputs 1 = tristate; 0 = output

**Table 11. Digital Output Signals**

Pin	Pin Name	Pin Description
23	EOS_YL	End-of-scan of YL shift register Low first clock period after last row (low active)
26	EOS_X	End-of-scan of X shift register Low first clock period after last active column (low active)
29	EOS_YR	End-of-scan of YR shift register Low first clock period after last row (low active)
55	D0	ADC output bit (LSB)
56	D1	ADC output bit
57	D2	ADC output bit



**Table 11. Digital Output Signals**

Pin	Pin Name	Pin Description
58	D3	ADC output bit
59	D4	ADC output bit
60	D5	ADC output bit
61	D6	ADC output bit
62	D7	ADC output bit
63	D8	ADC output bit
64	D9	ADC output bit (MSB)

**Table 12. Analog Input Signals**

Pin	Pin Name	Pin Description
39	NBIASARR	Connect with 470 k to $V_{DD}$ and decouple to ground with a 100 nF capacitor.
40	PBIAS	Connect with 39 k to ground and decouple to $V_{DD}$ with a 100 nF capacitor for 8 MHz pixel rate. (Lower resistor values yield higher maximal pixel rates at the cost of extra power dissipation).
41	NBIAS_AMP	Output amplifier speed/power control. Connect with 51 k $\Omega$ to $V_{DD}$ and decouple with 100 nF to GND for 8 MHz output rate (Lower resistor values yield higher maximal pixel rates at the cost of extra power dissipation).
42	BLACKREF	Control voltage for output signal offset level. Buffered on-chip, the reference level can be generated by a 100 k $\Omega$ resistive divider. Connect to $\pm 2$ V DC for use with on-chip ADC.
44	IN_ADC	Input, connect to sensor output. Input range is between 2 and 4 V ( $V_{LOW\_ADC}$ and $V_{HIGH\_ADC}$ ).
45	NBIASANA2	Connect with 100 k to $V_{DD}$ and decouple to GND.
46	NBIASANA	Connect with 100 k to $V_{DD}$ and decouple to GND.
47 70	$V_{LOW\_ADC}$ $V_{HIGH\_ADC}$	Low reference and high reference voltages of ADC should be about 2 V and 4 V. The required voltage settings on $V_{LOW\_ADC}$ and $V_{HIGH\_ADC}$ can be approximated by tying $V_{LOW\_ADC}$ with 1.2 k $\Omega$ to GND and $V_{HIGH\_ADC}$ with 560 $\Omega$ to $V_{DD}$ .
48	G_AB	Antiblooming drain control voltage: Default: connect to ground. The antiblooming is operational but not maximal. Apply 1 V DC for improved antiblooming.
72	PBIASDIG2	Connect with 100 K to GND and decouple to $V_{DD}$ .
73	PBIASENCLOAD	Connect with 100 K to GND and decouple to $V_{DD}$ .
74	PBIASDIG1	Connect with 47 K to GND and decouple to $V_{DD}$ .

**Table 13. Analog Output Signals**

Pin	Pin Name	Pin Description
43	OUT	Analog output signal are connected to the analog input of the ADC.

**Table 14. Test Structures**

Pin	Pin Name	Pin Description
81	TESTDIODE	Plain photo diode, size: 14 x 25 pixels. Must be left open for normal operation.
82	TESTPIX ARRAY	Array of test pixels, connected in parallel (14 x 25 pixels). Must be left open for normal operation.
83	TESTPIXEL_RESET	Reset input of single test pixel. Must be tied to GND for normal operation.
84	TESTPIXEL_OUT	Output of single test pixel. Must be left open for normal operation.

Package

Package with Glass

Figure 13. STAR250 Package Dimensions

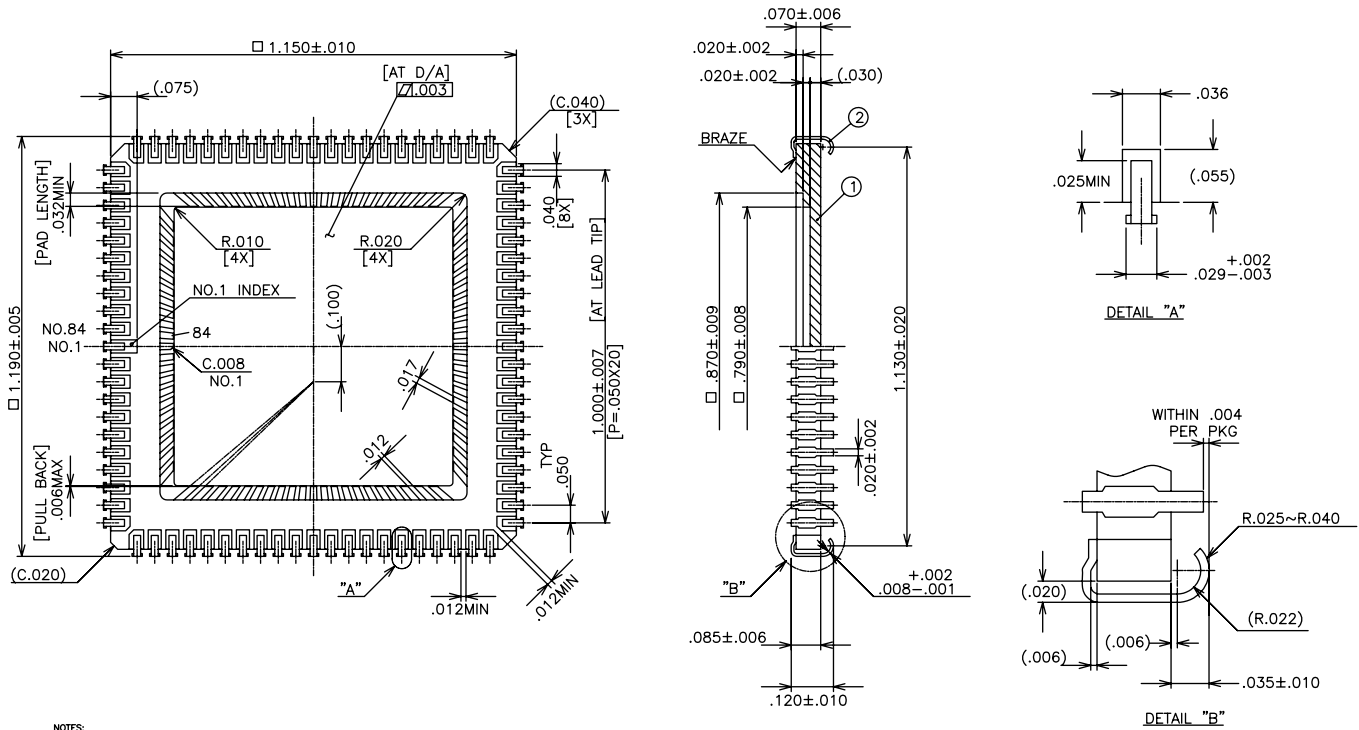

- NOTES:
1. GOLD PLATE 0.76µm MIN OVER 2µm MIN NICKEL, EXCEPT CUTTING SURFACE OF LEAD.
  2. NO LEAD TO BE ELECTRICALLY CONNECTED TO THE DIE ATTACH PAD.
  3. LEAD RESISTANCE 500µm MAX.
  4. DIE ATTACH CAVITY IS METALLIZED.
  5. DRAWING IS AN EXACT COPY OF SUPPLIER DRAWING IFR84FD-2741A.

001-07592 \*C

Note All dimensions in Figure 13 are measured in inches.

Table 15. Package Specifications:

Type	JLCC-84
Material	Black Alumina BA-914
Thermal expansion coefficient	$7.6 \times 10^{-6} /K$

Table 16. Mechanical Specifications

Characteristics	Limits			Units
	Min	Typ	Max	
Package tolerance	-	-	0.15	mm
Die position, X offset	-0.05	0	0.05	mm
Die position, Y offset	-0.018	-	0.118	mm
Die position, planarity	-0.05	0	0.05	mm
Die position, Y tilt	-0.05	0	0.05	mm

Note Min and Max limits are not measured on every unit, but guaranteed by assembly process.

Die Alignment

Figure 14. Die Alignment

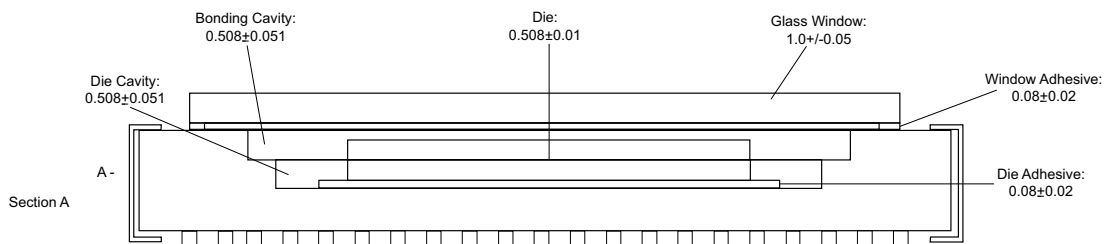
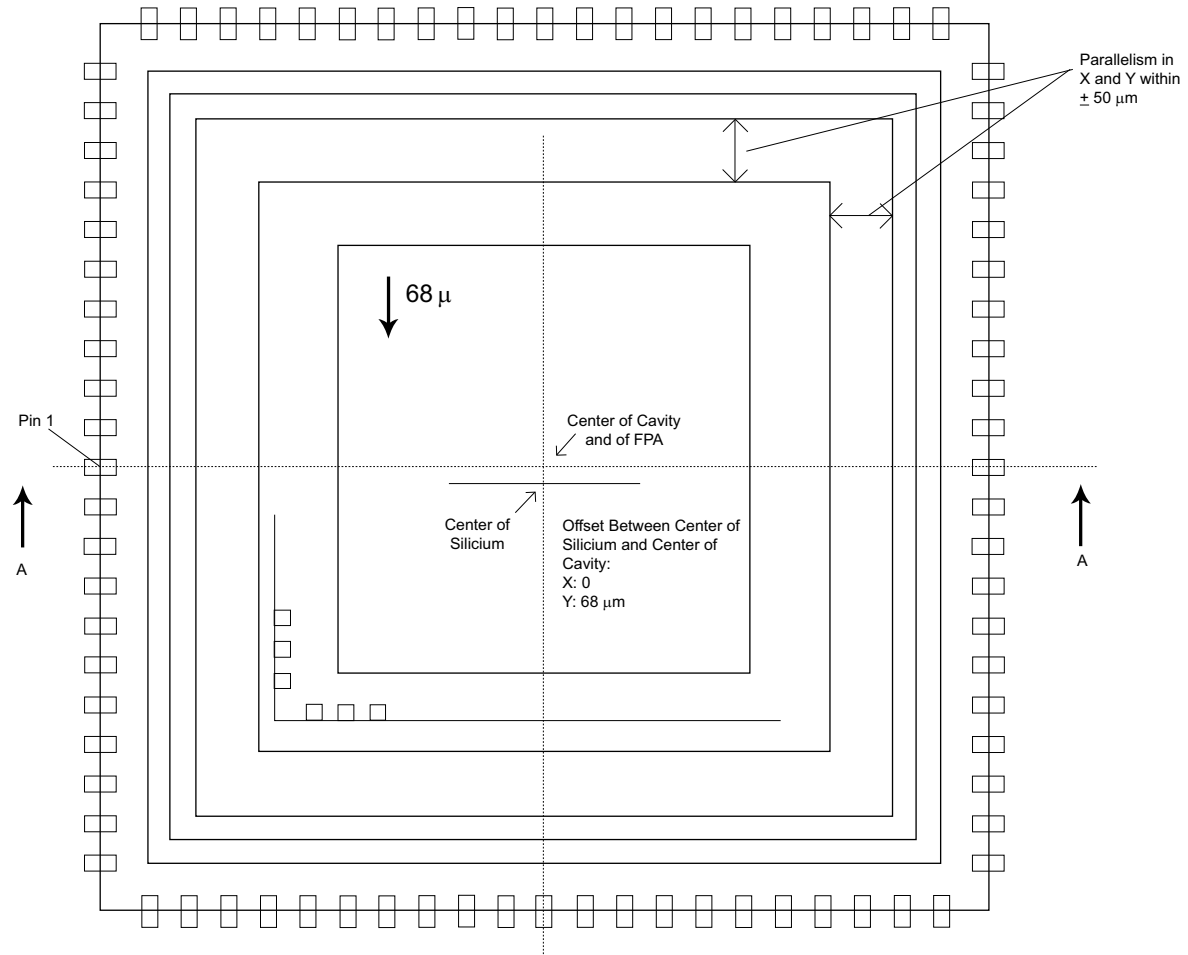

Drawing Not to Scale

The die is aligned manually in the package to a tolerance of ±50 μm and the alignment is verified after hardening the die adhesive. All dimensions in Figure 14 are in mm.

**Window Specifications**

STAR250

**Table 17. STAR250 Glass Cover Specifications:**

Material	Fused Silica
Dimensions	25 x 25 mm ± 0.2 mm
Thickness	1 mm ± 0.05 mm
Anti reflective coating	No
Cavity fill	Air

STAR250BK7

**Table 18. STAR250BK7 Glass Cover Specifications**

Material	BK7G18
Dimensions	25 x 25 mm ± 0.2 mm
Thickness	1 mm ± 0.05 mm
Anti reflective coating	Yes
Cavity fill	N <sub>2</sub>

**Ordering Code Definition**

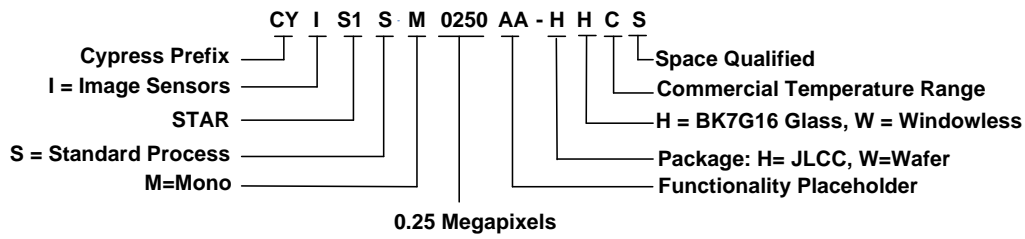

## Soldering and Handling

### Handling Precautions

For proper handling and storage conditions, refer to the Cypress application note [AN52561](#) at [www.cypress.com](http://www.cypress.com).

### Limited Warranty

Cypress Image Sensor Business Unit warrants that the image sensor products mentioned here, if properly used and serviced, conform to the seller's published specifications. They are free from defects in material and workmanship for one (1) year following the date of shipment.

### RoHS (Pb-free) Compliance

This section reports the use of hazardous chemical substances as required by the RoHS Directive (excluding packing material).

**Table 19. Chemical Substances in STAR250 Sensor**

Chemical Substance	Any Intentional Content	If there is any intentional content, in which portion is it contained?
Lead	No	–
Cadmium	No	–
Mercury	No	–
Hexavalent chromium	No	–
PBB (Polybrominated biphenyls)	No	–
PBDE (Polybrominated diphenyl ethers)	No	–

### Information on Pb-free Soldering

The product cannot withstand a Pb-free soldering process. Reflow or wave soldering is not allowed; hand soldering only. Solder one pin on each side of the sensor and allow it to cool for at least one minute before continuing.

**Note** "Intentional content" is defined as any material demanding special attention that is contained in the inquired product by the following cases:

1. A case that the above material is added as a chemical composition into the inquired product intentionally to produce and maintain the required performance and function of the intended product.
2. A case that the above material, which is used intentionally in the manufacturing process, is contained in or adhered to the inquired product.

The following case is not treated as "intentional content":

A case that the above material is contained as an impurity into raw materials or parts of the intended product. The impurity is defined as a substance that cannot be removed industrially, or it is produced at a process such as chemical composing or reaction and it cannot be removed technically.

### Evaluation Kit

For evaluating purposes, a STAR250 evaluation kit is available. This kit consists of a multifunctional digital board (memory, sequencer, and IEEE 1394 Fire Wire interface) and an analog image sensor board. Visual Basic software (in Windows 2000 or XP) allows to grab and display images from the sensor. All acquired images can be stored in different file formats (8 or 16-bit). The settings can be adjusted on the fly to evaluate the sensor specifications. Default register values can be loaded to start the software in a desired state.

## Acronyms

Acronym	Definition
ADC	analog to digital convertor
CIS	CMOS image sensor
CMOS	complementary metal oxide semiconductor
CY	Cypress
DC	dark current
DNL	differential nonlinearity
DS	double sampling
DSNU	dark signal nonuniformity
ESD	electrostatic discharge
FF	fill factor
FPN	fixed pattern noise
FPS	frames per second
FS	frame start
fs	full scale
I/O	input/output
IMG	image
INL	integral nonlinearity
IP	intellectual property
LDO	low drop-out
LSB	least significant bit
LVDS	low voltage differential signaling
MBS	mixed boundary scan

Acronym	Definition
MBPS	megabit per second
MCIS	multifield point CMOS image sensor
MFF	metal fill factor
MIM	metal-insulator-metal
MP	megapixel
Mrad	megaradiation
MSB	most significant bit
MSPS	megasamples per second
MTF	modulation transfer function
MUX	multiplexer
PCB	printed circuit board
PLL	phase-locked loop
PLS	parasitic light sensitivity
PRBS	pseudo random bit stream
PRNU	photo response nonuniformity
PSN	photon shot noise
PSNL	pixel storage node leakage
QC	quantum conversion
QE	quantum efficiency
QFW	pixel full-well charge
RMS	root mean square
ROI	region of interest

## Document History Page

Document Title: CYIS1SM0250AA STAR250 250K Pixel Radiation Hard CMOS Image Sensor Document Number: 38-05713				
Rev.	ECN No.	Submission Date	Orig. of Change	Description of Change
**	310213	See ECN	SIL	Origination
*A	603159	See ECN	QGS	Converted to Framemaker Format
*B	649360	See ECN	FPW	Title update + package spec label
*C	2766198	09/19/09	NVEA	Updated Ordering Information table
*D	2788268	10/16/2009	NVEA	Added Mechanical Specifications table Updated Soldering and Handling information
*E	2934134	5/20/2010	NVEA	Added table of contents and acronym table. Added CYIS1SM0250AA-WXC to Ordering Information table. Updated package drawing
*F	3104861	12/08/2010	NVEA	Added CYIS1SM0250AA-WWC to the Ordering Information table and removed pruned parts Updated package diagram

## Sales, Solutions, and Legal Information

### Worldwide Sales and Design Support

Cypress offers standard and customized CMOS image sensors for consumer as well as industrial and professional applications. Consumer applications include solutions for fast growing high speed machine vision, motion monitoring, medical imaging, intelligent traffic systems, security, and barcode applications. Cypress's customized CMOS image sensors are characterized by very high pixel counts, large area, very high frame rates, large dynamic range, and high sensitivity.

Cypress maintains a worldwide network of offices, solution centers, manufacturer's representatives, and distributors. For more information on Image sensors, contact [imagesensors@cypress.com](mailto:imagesensors@cypress.com).

© Cypress Semiconductor Corporation, 2006-2010. The information contained herein is subject to change without notice. Cypress Semiconductor Corporation assumes no responsibility for the use of any circuitry other than circuitry embodied in a Cypress product. Nor does it convey or imply any license under patent or other rights. Cypress products are not warranted nor intended to be used for medical, life support, life saving, critical control or safety applications, unless pursuant to an express written agreement with Cypress. Furthermore, Cypress does not authorize its products for use as critical components in life-support systems where a malfunction or failure may reasonably be expected to result in significant injury to the user. The inclusion of Cypress products in life-support systems application implies that the manufacturer assumes all risk of such use and in doing so indemnifies Cypress against all charges.

Any Source Code (software and/or firmware) is owned by Cypress Semiconductor Corporation (Cypress) and is protected by and subject to worldwide patent protection (United States and foreign), United States copyright laws and international treaty provisions. Cypress hereby grants to licensee a personal, non-exclusive, non-transferable license to copy, use, modify, create derivative works of, and compile the Cypress Source Code and derivative works for the sole purpose of creating custom software and/or firmware in support of licensee product to be used only in conjunction with a Cypress integrated circuit as specified in the applicable agreement. Any reproduction, modification, translation, compilation, or representation of this Source Code except as specified above is prohibited without the express written permission of Cypress.

Disclaimer: CYPRESS MAKES NO WARRANTY OF ANY KIND, EXPRESS OR IMPLIED, WITH REGARD TO THIS MATERIAL, INCLUDING, BUT NOT LIMITED TO, THE IMPLIED WARRANTIES OF MERCHANTABILITY AND FITNESS FOR A PARTICULAR PURPOSE. Cypress reserves the right to make changes without further notice to the materials described herein. Cypress does not assume any liability arising out of the application or use of any product or circuit described herein. Cypress does not authorize its products for use as critical components in life-support systems where a malfunction or failure may reasonably be expected to result in significant injury to the user. The inclusion of Cypress' product in a life-support systems application implies that the manufacturer assumes all risk of such use and in doing so indemnifies Cypress against all charges.

Use may be limited by and subject to the applicable Cypress software license agreement.