

# MC78M00, MC78M00A, NCV78M00 Series

## 500 mA Positive Voltage Regulators

The MC78M00/MC78M00A Series positive voltage regulators are identical to the popular MC7800 Series devices, except that they are specified for only half the output current. Like the MC7800 devices, the MC78M00 three-terminal regulators are intended for local, on-card voltage regulation.

Internal current limiting, thermal shutdown circuitry and safe-area compensation for the internal pass transistor combine to make these devices remarkably rugged under most operating conditions. Maximum output current, with adequate heatsinking is 500 mA.

### Features

- No External Components Required
- Internal Thermal Overload Protection
- Internal Short Circuit Current Limiting
- Output Transistor Safe-Area Compensation
- MC78M00A High Accuracy ( $\pm 2\%$ )  
Available for 5.0 V, 8.0 V, 12 V and 15 V
- Pb-Free Packages are Available\*
- NCV Prefix for Automotive and Other Applications Requiring Site and Control Changes

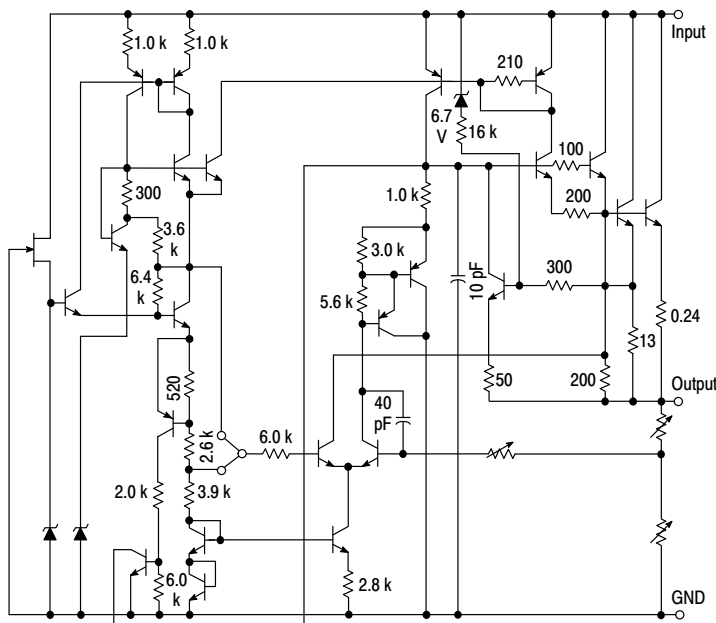

This device contains 28 active transistors.

**Figure 1. Representative Schematic Diagram**

\*For additional information on our Pb-Free strategy and soldering details, please download the ON Semiconductor Soldering and Mounting Techniques Reference Manual, SOLDERRM/D.



**ON Semiconductor®**

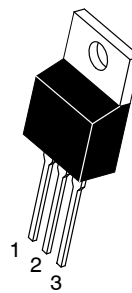

**TO-220  
T SUFFIX  
CASE 221AB**

Heatsink surface  
connected to Pin 2.

### MARKING DIAGRAMS

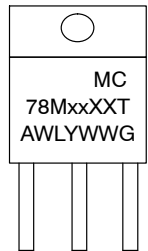

xx = Voltage Option  
XX = Appropriate Suffix Options  
A = Assembly Location  
WL = Wafer Lot  
Y = Year  
WW = Work Week  
G = Pb-Free Package

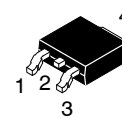

**DPAK-3  
DT SUFFIX  
CASE 369C**

Heatsink surface (shown as terminal 4 in  
case outline drawing) is connected to Pin 2.



xxxxx = Device Type and Voltage Option Code  
A = Assembly Location  
L = Wafer Lot  
Y = Year  
WW = Work Week  
G = Pb-Free Package

Pin 1. Input  
2. Ground  
3. Output

### ORDERING INFORMATION

See detailed ordering and shipping information in the package dimensions section on page 10-14 of this data sheet.

### DEVICE MARKING INFORMATION

See general marking information in the device marking section on page 10 of this data sheet.

## MC78M00, MC78M00A, NCV78M00 Series

### MAXIMUM RATINGS ( $T_A = 25^\circ\text{C}$ , unless otherwise noted) (Note 1)

Rating	Symbol	Value	Unit
Input Voltage (5.0 V–18 V) (20 V–24V)	$V_I$	35 40	Vdc
Power Dissipation (Package Limitation)			
Plastic Package, T Suffix $T_A = 25^\circ\text{C}$	$P_D$	Internally Limited	
Thermal Resistance, Junction–to–Air	$\theta_{JA}$	70	$^\circ\text{C/W}$
Thermal Resistance, Junction–to–Case	$\theta_{JC}$	5.0	$^\circ\text{C/W}$
Plastic Package, DT Suffix $T_A = 25^\circ\text{C}$	$P_D$	Internally Limited	
Thermal Resistance, Junction–to–Air	$\theta_{JA}$	92	$^\circ\text{C/W}$
Thermal Resistance, Junction–to–Case	$\theta_{JC}$	5.0	$^\circ\text{C/W}$
Operating Junction Temperature Range	$T_J$	+150	$^\circ\text{C}$
Storage Temperature Range	$T_{stg}$	–65 to +150	$^\circ\text{C}$

Stresses exceeding Maximum Ratings may damage the device. Maximum Ratings are stress ratings only. Functional operation above the Recommended Operating Conditions is not implied. Extended exposure to stresses above the Recommended Operating Conditions may affect device reliability.

1. This device series contains ESD protection and exceeds the following tests:

Human Body Model 2000 V per MIL–STD–883, Method 3015.

Machine Model Method 200 V.

### MC78M05C/AC/B/AB, NCV78M05AB/B ELECTRICAL CHARACTERISTICS ( $V_I = 10\text{ V}$ , $I_O = 350\text{ mA}$ , $T_J = T_{low}$ to $T_{high}$ , $P_D \leq 5\text{ W}$ , unless otherwise noted) (Note 2)

Characteristics	Symbol	Min	Typ	Max	Unit
Output Voltage ( $T_J = 25^\circ\text{C}$ ) MC78M05B/MC78M05C/NCV78M05B MC78M05AB/MC78M05AC/NCV78M05AB	$V_O$	4.8 4.9	5.0 5.0	5.2 5.1	Vdc
Output Voltage Variation (7.0 Vdc $\leq V_I \leq 20\text{ Vdc}$ , 5.0 mA $\leq I_O \leq 350\text{ mA}$ ) MC78M05B/MC78M05C/NCV78M05B MC78M05AB/MC78M05AC/NCV78M05AB	$V_O$	4.75 4.80	– –	5.25 5.20	Vdc
Line Regulation ( $T_J = 25^\circ\text{C}$ , 7.0 Vdc $\leq V_I \leq 25\text{ Vdc}$ , $I_O = 200\text{ mA}$ )	$Reg_{line}$	–	3.0	50	mV
Load Regulation ( $T_J = 25^\circ\text{C}$ , 5.0 mA $\leq I_O \leq 500\text{ mA}$ ) ( $T_J = 25^\circ\text{C}$ , 5.0 mA $\leq I_O \leq 200\text{ mA}$ )	$Reg_{load}$	– –	20 10	100 50	mV
Input Bias Current ( $T_J = 25^\circ\text{C}$ )	$I_{IB}$	–	3.2	6.0	mA
Quiescent Current Change (8.0 Vdc $\leq V_I \leq 25\text{ Vdc}$ , $I_O = 200\text{ mA}$ ) (5.0 mA $\leq I_O \leq 350\text{ mA}$ )	$\Delta I_{IB}$	– –	– –	0.8 0.5	mA
Output Noise Voltage ( $T_A = 25^\circ\text{C}$ , 10 Hz $\leq f \leq 100\text{ kHz}$ )	$V_n$	–	40	–	$\mu\text{V}$
Ripple Rejection ( $I_O = 100\text{ mA}$ , $f = 120\text{ Hz}$ , 8.0 V $\leq V_I \leq 18\text{ V}$ ) ( $I_O = 300\text{ mA}$ , $f = 120\text{ Hz}$ , 8.0 V $\leq V_I \leq 18\text{ V}$ , $T_J = 25^\circ\text{C}$ )	RR	62 62	– 80	– –	dB
Dropout Voltage ( $T_J = 25^\circ\text{C}$ )	$V_I - V_O$	–	2.0	–	Vdc
Short Circuit Current Limit ( $T_J = 25^\circ\text{C}$ , $V_I = 35\text{ V}$ )	$I_{OS}$	–	350	–	mA
Average Temperature Coefficient of Output Voltage ( $I_O = 5.0\text{ mA}$ )	$\Delta V_O / \Delta T$	–	$\pm 0.2$	–	$\text{mV}/^\circ\text{C}$
Peak Output Current ( $T_J = 25^\circ\text{C}$ )	$I_O$	–	700	–	mA

2.  $T_{low} = 0^\circ\text{C}$  for MC78MxxAC, C  $T_{high} = +125^\circ\text{C}$  for MC78MxxAB, AC, B, C, NCV78MxxAB, B  
 $= -40^\circ\text{C}$  for MC78MxxAB, B, NCV78MxxAB, B

## MC78M00, MC78M00A, NCV78M00 Series

### ORDERING INFORMATION

Device	Output Voltage	Temperature Range	Package	Marking	Shipping <sup>†</sup>	
MC78M05CDT	5.0 V	$T_J = 0^\circ \text{ to } +125^\circ\text{C}$	DPAK-3	78M05	75 Units / Rail	
MC78M05CDTG			DPAK-3 (Pb-Free)	78M05		
MC78M05CDTT5G			DPAK-3 (Pb-Free)	78M05	2500 Units / Tape & Reel	
MC78M05CDTRK			DPAK-3	78M05		
MC78M05CDTRKG			DPAK-3 (Pb-Free)	78M05		
MC78M05ACDT			DPAK-3	8M05D		75 Units / Rail
MC78M05ACDTG			DPAK-3 (Pb-Free)	8M05D		
MC78M05ACDTRK			DPAK-3	8M05D	2500 Units / Tape & Reel	
MC78M05ACDTRKG			DPAK-3 (Pb-Free)	8M05D		
MC78M05CT			TO-220	78M05CT	50 Units / Rail	
MC78M05CTG			TO-220 (Pb-Free)	78M05CT		
MC78M05ACT			TO-220	78M05ACT	50 Units / Rail	
MC78M05ACTG			TO-220 (Pb-Free)	78M05ACT		
MC78M05ABDT			$T_J = -40^\circ \text{ to } +125^\circ\text{C}$		DPAK-3	8M05A
MC78M05ABDTG		DPAK-3 (Pb-Free)			8M05A	
MC78M05ABDTRK		DPAK-3			8M05A	2500 Units / Tape & Reel
MC78M05ABDTRKG		DPAK-3 (Pb-Free)			8M05A	
MC78M05ABT		TO-220			78M05ABT	50 Units / Rail
MC78M05ABTG		TO-220 (Pb-Free)			78M05ABT	
MC78M05BDT		DPAK-3			8M05B	75 Units / Rail
MC78M05BDTG	DPAK-3 (Pb-Free)	8M05B				
MC78M05BDTT5G	DPAK-3 (Pb-Free)	8M05B			2500 Units / Tape & Reel	
MC78M05BDTRK	DPAK-3	8M05B				
MC78M05BDTRKG	DPAK-3 (Pb-Free)	8M05B				
NCV78M05BDTRK*	DPAK-3	8M05B				
NCV78M05BDTRKG*	DPAK-3 (Pb-Free)	8M05B			50 Units / Rail	
MC78M05BT	TO-220	78M05BT				
MC78M05BTG	TO-220 (Pb-Free)	78M05BT			50 Units / Rail	
NCV78M05BTG*	TO-220 (Pb-Free)	78M05BT				

<sup>†</sup>For information on tape and reel specifications, including part orientation and tape sizes, please refer to our Tape and Reel Packaging Specifications Brochure, BRD8011/D.

\*NCV devices:  $T_{low} = -40^\circ\text{C}$ ,  $T_{high} = +125^\circ\text{C}$ . Guaranteed by design. NCV prefix is for automotive and other applications requiring site and control change.

# MC78M00, MC78M00A, NCV78M00 Series

## PACKAGE DIMENSIONS

DPAK-3  
DT SUFFIX  
CASE 369C-01  
ISSUE O

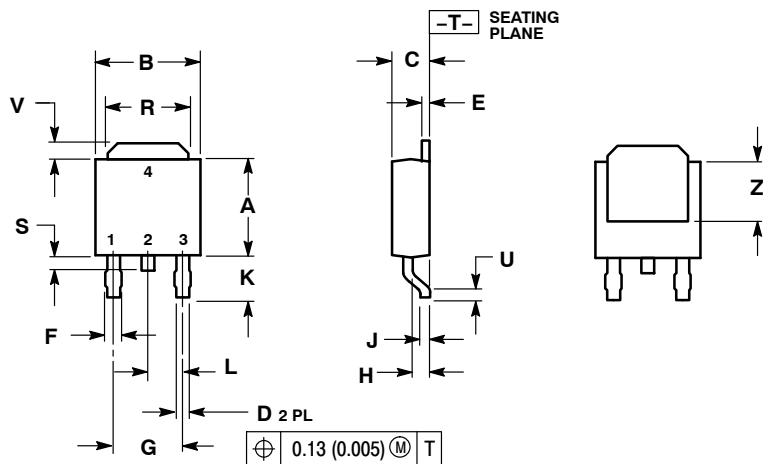

NOTES:  
1. DIMENSIONING AND TOLERANCING PER ANSI Y14.5M, 1982.  
2. CONTROLLING DIMENSION: INCH.

DIM	INCHES		MILLIMETERS	
	MIN	MAX	MIN	MAX
A	0.235	0.245	5.97	6.22
B	0.250	0.265	6.35	6.73
C	0.086	0.094	2.19	2.38
D	0.027	0.035	0.69	0.88
E	0.018	0.023	0.46	0.58
F	0.037	0.045	0.94	1.14
G	0.180 BSC		4.58 BSC	
H	0.034	0.040	0.87	1.01
J	0.018	0.023	0.46	0.58
K	0.102	0.114	2.60	2.89
L	0.090 BSC		2.29 BSC	
R	0.180	0.215	4.57	5.45
S	0.025	0.040	0.63	1.01
U	0.020	---	0.51	---
V	0.035	0.050	0.89	1.27
Z	0.155	---	3.93	---

### SOLDERING FOOTPRINT\*

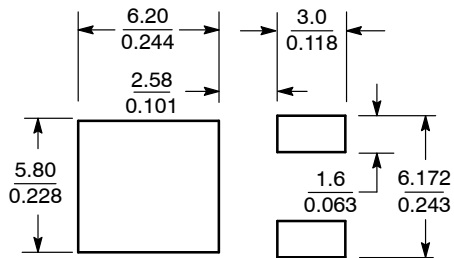

SCALE 3:1 ( $\frac{\text{mm}}{\text{inches}}$ )

\*For additional information on our Pb-Free strategy and soldering details, please download the ON Semiconductor Soldering and Mounting Techniques Reference Manual, SOLDERRM/D.

# MC78M00, MC78M00A, NCV78M00 Series

## PACKAGE DIMENSIONS

TO-220, SINGLE GAUGE  
T SUFFIX  
CASE 221AB-01  
ISSUE O

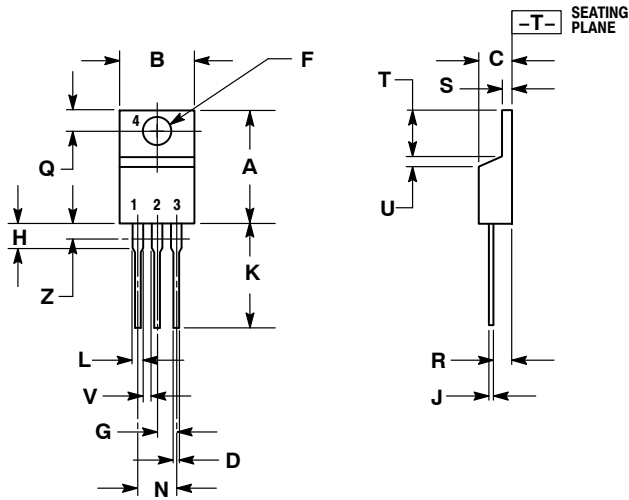

NOTES:

1. DIMENSIONING AND TOLERANCING PER ANSI Y14.5M, 1982.
2. CONTROLLING DIMENSION: INCH.
3. DIMENSION Z DEFINES A ZONE WHERE ALL BODY AND LEAD IRREGULARITIES ARE ALLOWED.

DIM	INCHES		MILLIMETERS	
	MIN	MAX	MIN	MAX
A	0.570	0.620	14.48	15.75
B	0.380	0.405	9.66	10.28
C	0.160	0.190	4.07	4.82
D	0.025	0.035	0.64	0.88
F	0.142	0.147	3.61	3.73
G	0.095	0.105	2.42	2.66
H	0.110	0.155	2.80	3.93
J	0.018	0.025	0.46	0.64
K	0.500	0.562	12.70	14.27
L	0.045	0.060	1.15	1.52
N	0.190	0.210	4.83	5.33
Q	0.100	0.120	2.54	3.04
R	0.080	0.110	2.04	2.79
S	0.020	0.055	0.508	1.39
T	0.235	0.255	5.97	6.47
U	0.000	0.050	0.00	1.27
V	0.045	---	1.15	---
Z	---	0.080	---	2.04