

AD594/AD595

FEATURES

Pretrimmed for Type J (AD594) or Type K (AD595) Thermocouples
Can Be Used with Type T Thermocouple Inputs
Low Impedance Voltage Output: 10 mV/°C
Built-In Ice Point Compensation
Wide Power Supply Range: +5 V to ±15 V
Low Power: <1 mW typical
Thermocouple Failure Alarm
Laser Wafer Trimmed to 1°C Calibration Accuracy
Setpoint Mode Operation
Self-Contained Celsius Thermometer Operation
High Impedance Differential Input
Side-Brazed DIP or Low Cost Cerdip

PRODUCT DESCRIPTION

The AD594/AD595 is a complete instrumentation amplifier and thermocouple cold junction compensator on a monolithic chip. It combines an ice point reference with a precalibrated amplifier to produce a high level (10 mV/°C) output directly from a thermocouple signal. Pin-strapping options allow it to be used as a linear amplifier-compensator or as a switched output setpoint controller using either fixed or remote setpoint control. It can be used to amplify its compensation voltage directly, thereby converting it to a stand-alone Celsius transducer with a low impedance voltage output.

The AD594/AD595 includes a thermocouple failure alarm that indicates if one or both thermocouple leads become open. The alarm output has a flexible format which includes TTL drive capability.

The AD594/AD595 can be powered from a single ended supply (including +5 V) and by including a negative supply, temperatures below 0°C can be measured. To minimize self-heating, an unloaded AD594/AD595 will typically operate with a total supply current 160 µA, but is also capable of delivering in excess of ±5 mA to a load.

The AD594 is precalibrated by laser wafer trimming to match the characteristic of type J (iron-constantan) thermocouples and the AD595 is laser trimmed for type K (chromel-alumel) inputs. The temperature transducer voltages and gain control resistors

FUNCTIONAL BLOCK DIAGRAM

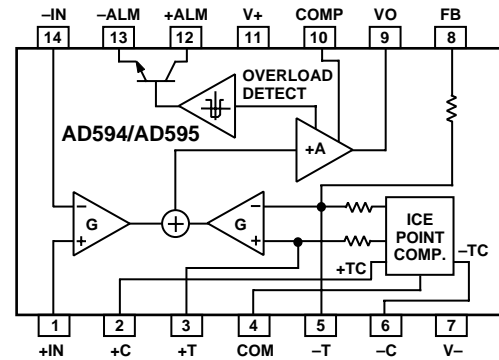

are available at the package pins so that the circuit can be recalibrated for the thermocouple types by the addition of two or three resistors. These terminals also allow more precise calibration for both thermocouple and thermometer applications.

The AD594/AD595 is available in two performance grades. The C and the A versions have calibration accuracies of ±1°C and ±3°C, respectively. Both are designed to be used from 0°C to +50°C, and are available in 14-pin, hermetically sealed, side-brazed ceramic DIPs as well as low cost cerdip packages.

PRODUCT HIGHLIGHTS

1. The AD594/AD595 provides cold junction compensation, amplification, and an output buffer in a single IC package.
2. Compensation, zero, and scale factor are all precalibrated by laser wafer trimming (LWT) of each IC chip.
3. Flexible pinout provides for operation as a setpoint controller or a stand-alone temperature transducer calibrated in degrees Celsius.
4. Operation at remote application sites is facilitated by low quiescent current and a wide supply voltage range +5 V to dual supplies spanning 30 V.
5. Differential input rejects common-mode noise voltage on the thermocouple leads.

REV. C

Information furnished by Analog Devices is believed to be accurate and reliable. However, no responsibility is assumed by Analog Devices for its use, nor for any infringements of patents or other rights of third parties which may result from its use. No license is granted by implication or otherwise under any patent or patent rights of Analog Devices.

AD594/AD595—SPECIFICATIONS (@ +25°C and $V_S = 5\text{ V}$, Type J (AD594), Type K (AD595) Thermocouple, unless otherwise noted)

Model	AD594A			AD594C			AD595A			AD595C			Units
	Min	Typ	Max	Min	Typ	Max	Min	Typ	Max	Min	Typ	Max	
ABSOLUTE MAXIMUM RATING													
$+V_S$ to $-V_S$			36			36			36			36	Volts
Common-Mode Input Voltage	$-V_S - 0.15$		$+V_S$	$-V_S - 0.15$		$+V_S$	$-V_S - 0.15$		$+V_S$	$-V_S - 0.15$		$+V_S$	Volts
Differential Input Voltage	$-V_S$		$+V_S$	$-V_S$		$+V_S$	$-V_S$		$+V_S$	$-V_S$		$+V_S$	Volts
Alarm Voltages													
+ALM	$-V_S$		$-V_S + 36$	$-V_S$		$-V_S + 36$	$-V_S$		$-V_S + 36$	$-V_S$		$-V_S + 36$	Volts
-ALM	$-V_S$		$+V_S$	$-V_S$		$+V_S$	$-V_S$		$+V_S$	$-V_S$		$+V_S$	Volts
Operating Temperature Range	-55		+125	-55		+125	-55		+125	-55		+125	°C
Output Short Circuit to Common	Indefinite			Indefinite			Indefinite			Indefinite			
TEMPERATURE MEASUREMENT (Specified Temperature Range 0°C to +50°C)													
Calibration Error at +25°C ¹			±3			±1			±3			±1	°C
Stability vs. Temperature ²			±0.05			±0.025			±0.05			±0.025	°C/°C
Gain Error			±1.5			±0.75			±1.5			±0.75	%
Nominal Transfer Function			10			10			10			10	mV/°C
AMPLIFIER CHARACTERISTICS													
Closed Loop Gain ³	193.4			193.4			247.3			247.3			
Input Offset Voltage	(Temperature in °C) × 51.70 μV/°C			(Temperature in °C) × 51.70 μV/°C			(Temperature in °C) × 40.44 μV/°C			(Temperature in °C) × 40.44 μV/°C			μV
Input Bias Current	0.1			0.1			0.1			0.1			μA
Differential Input Range	-10		+50	-10		+50	-10		+50	-10		+50	mV
Common-Mode Range	$-V_S - 0.15$		$-V_S - 4$	$-V_S - 0.15$		$-V_S - 4$	$-V_S - 0.15$		$-V_S - 4$	$-V_S - 0.15$		$-V_S - 4$	Volts
Common-Mode Sensitivity – RTO	10			10			10			10			mV/V
Power Supply Sensitivity – RTO	10			10			10			10			mV/V
Output Voltage Range													
Dual Supply	$-V_S + 2.5$		$+V_S - 2$	$-V_S + 2.5$		$+V_S - 2$	$-V_S + 2.5$		$+V_S - 2$	$-V_S + 2.5$		$+V_S - 2$	Volts
Single Supply	0		$+V_S - 2$	0		$+V_S - 2$	0		$+V_S + 2$	0		$+V_S - 2$	Volts
Usable Output Current ⁴		±5			±5			±5			±5		mA
3 dB Bandwidth	15			15			15			15			kHz
ALARM CHARACTERISTICS													
$V_{CE(SAT)}$ at 2 mA	0.3			0.3			0.3			0.3			Volts
Leakage Current	±1			±1			±1			±1			μA max
Operating Voltage at -ALM	$+V_S - 4$			$+V_S - 4$			$+V_S - 4$			$+V_S - 4$			Volts
Short Circuit Current	20			20			20			20			mA
POWER REQUIREMENTS													
Specified Performance Operating ⁵	$+V_S = 5, -V_S = 0$ $+V_S$ to $-V_S \leq 30$			$+V_S = 5, -V_S = 0$ $+V_S$ to $-V_S \leq 30$			$+V_S = 5, -V_S = 0$ $+V_S$ to $-V_S \leq 30$			$+V_S = 5, -V_S = 0$ $+V_S$ to $-V_S \leq 30$			Volts
Quiescent Current (No Load)													
+ V_S		160	300		160	300		160	300		160	300	μA
- V_S		100			100			100			100		μA
PACKAGE OPTION													
TO-116 (D-14)	AD594AD			AD594CD			AD595AD			AD595CD			
Cerdip (Q-14)	AD594AQ			AD594CQ			AD595AQ			AD595CQ			

NOTES
¹Calibrated for minimum error at +25°C using a thermocouple sensitivity of 51.7 μV/°C. Since a J type thermocouple deviates from this straight line approximation, the AD594 will normally read 3.1 mV when the measuring junction is at 0°C. The AD595 will similarly read 2.7 mV at 0°C.
²Defined as the slope of the line connecting the AD594/AD595 errors measured at 0°C and 50°C ambient temperature.
³Pin 8 shorted to Pin 9.
⁴Current Sink Capability in single supply configuration is limited to current drawn to ground through a 50 kΩ resistor at output voltages below 2.5 V.
⁵- V_S must not exceed -16.5 V.

Specifications shown in **boldface** are tested on all production units at final electrical test. Results from those tests are used to calculate outgoing quality levels. All min and max specifications are guaranteed, although only those shown in **boldface** are tested on all production units. Specifications subject to change without notice.

INTERPRETING AD594/AD595 OUTPUT VOLTAGES

To achieve a temperature proportional output of 10 mV/°C and accurately compensate for the reference junction over the rated operating range of the circuit, the AD594/AD595 is gain trimmed to match the transfer characteristic of J and K type thermocouples at 25°C. For a type J output in this temperature range the TC is 51.70 μV/°C, while for a type K it is 40.44 μV/°C. The resulting gain for the AD594 is 193.4 (10 mV/°C divided by 51.7 μV/°C) and for the AD595 is 247.3 (10 mV/°C divided by 40.44 μV/°C). In addition, an absolute accuracy trim induces an input offset to the output amplifier characteristic of 16 μV for the AD594 and 11 μV for the AD595. This offset arises because the AD594/AD595 is trimmed for a 250 mV output while applying a 25°C thermocouple input.

Because a thermocouple output voltage is nonlinear with respect to temperature, and the AD594/AD595 linearly amplifies the

compensated signal, the following transfer functions should be used to determine the actual output voltages:

$$AD594 \text{ output} = (\text{Type J Voltage} + 16 \mu\text{V}) \times 193.4$$

$$AD595 \text{ output} = (\text{Type K Voltage} + 11 \mu\text{V}) \times 247.3 \text{ or conversely:}$$

$$\text{Type J voltage} = (AD594 \text{ output}/193.4) - 16 \mu\text{V}$$

$$\text{Type K voltage} = (AD595 \text{ output}/247.3) - 11 \mu\text{V}$$

Table I lists the ideal AD594/AD595 output voltages as a function of Celsius temperature for type J and K ANSI standard thermocouples, with the package and reference junction at 25°C. As is normally the case, these outputs are subject to calibration, gain and temperature sensitivity errors. Output values for intermediate temperatures can be interpolated, or calculated using the output equations and ANSI thermocouple voltage tables referred to zero degrees Celsius. Due to a slight variation in alloy content between ANSI type J and DIN FE-CUNI

Table I. Output Voltage vs. Thermocouple Temperature (Ambient +25°C, $V_S = -5\text{ V}, +15\text{ V}$)

Thermocouple Temperature °C	Type J Voltage mV	AD594 Output mV	Type K Voltage mV	AD595 Output mV
-200	-7.890	-1523	-5.891	-1454
-180	-7.402	-1428	-5.550	-1370
-160	-6.821	-1316	-5.141	-1269
-140	-6.159	-1188	-4.669	-1152
-120	-5.426	-1046	-4.138	-1021
-100	-4.632	-893	-3.553	-876
-80	-3.785	-729	-2.920	-719
-60	-2.892	-556	-2.243	-552
-40	-1.960	-376	-1.527	-375
-20	-.995	-189	-.777	-189
-10	-.501	-94	-.392	-94
0	0	3.1	0	2.7
10	.507	101	.397	101
20	1.019	200	.798	200
25	1.277	250	1.000	250
30	1.536	300	1.203	300
40	2.058	401	1.611	401
50	2.585	503	2.022	503
60	3.115	606	2.436	605
80	4.186	813	3.266	810
100	5.268	1022	4.095	1015
120	6.359	1233	4.919	1219
140	7.457	1445	5.733	1420
160	8.560	1659	6.539	1620
180	9.667	1873	7.338	1817
200	10.777	2087	8.137	2015
220	11.887	2302	8.938	2213
240	12.998	2517	9.745	2413
260	14.108	2732	10.560	2614
280	15.217	2946	11.381	2817
300	16.325	3160	12.207	3022
320	17.432	3374	13.039	3227
340	18.537	3588	13.874	3434
360	19.640	3801	14.712	3641
380	20.743	4015	15.552	3849
400	21.846	4228	16.395	4057
420	22.949	4441	17.241	4266
440	24.054	4655	18.088	4476
460	25.161	4869	18.938	4686
480	26.272	5084	19.788	4896
500	27.388	5300	20.640	5107
520	28.511	5517	21.493	5318
540	29.642	5736	22.346	5529
560	30.782	5956	23.198	5740
580	31.933	6179	24.050	5950
600	33.096	6404	24.902	6161
620	34.273	6632	25.751	6371
640	35.464	6862	26.599	6581
660	36.671	7095	27.445	6790
680	37.893	7332	28.288	6998
700	39.130	7571	29.128	7206
720	40.382	7813	29.965	7413
740	41.647	8058	30.799	7619
750	42.283	8181	31.214	7722
760	-	-	31.629	7825
780	-	-	32.455	8029
800	-	-	33.277	8232
820	-	-	34.095	8434
840	-	-	34.909	8636
860	-	-	35.718	8836
880	-	-	36.524	9035
900	-	-	37.325	9233
920	-	-	38.122	9430
940	-	-	38.915	9626
960	-	-	39.703	9821
980	-	-	40.488	10015
1000	-	-	41.269	10209
1020	-	-	42.045	10400
1040	-	-	42.817	10591
1060	-	-	43.585	10781
1080	-	-	44.339	10970
1100	-	-	45.108	11158
1120	-	-	45.863	11345
1140	-	-	46.612	11530
1160	-	-	47.356	11714
1180	-	-	48.095	11897
1200	-	-	48.828	12078
1220	-	-	49.555	12258
1240	-	-	50.276	12436
1250	-	-	50.633	12524

thermocouples Table I should not be used in conjunction with European standard thermocouples. Instead the transfer function given previously and a DIN thermocouple table should be used. ANSI type K and DIN NiCr-Ni thermocouples are composed



Figure 1. Basic Connection, Single Supply Operation

of identical alloys and exhibit similar behavior. The upper temperature limits in Table I are those recommended for type J and type K thermocouples by the majority of vendors.

SINGLE AND DUAL SUPPLY CONNECTIONS

The AD594/AD595 is a completely self-contained thermocouple conditioner. Using a single +5 V supply the interconnections shown in Figure 1 will provide a direct output from a type J thermocouple (AD594) or type K thermocouple (AD595) measuring from 0°C to +300°C.

Any convenient supply voltage from +5 V to +30 V may be used, with self-heating errors being minimized at lower supply levels. In the single supply configuration the +5 V supply connects to Pin 11 with the V- connection at Pin 7 strapped to power and signal common at Pin 4. The thermocouple wire inputs connect to Pins 1 and 14 either directly from the measuring point or through intervening connections of similar thermocouple wire type. When the alarm output at Pin 13 is not used it should be connected to common or -V. The precalibrated feedback network at Pin 8 is tied to the output at Pin 9 to provide a 10 mV/°C nominal temperature transfer characteristic.

By using a wider ranging dual supply, as shown in Figure 2, the AD594/AD595 can be interfaced to thermocouples measuring both negative and extended positive temperatures.

AD594/AD595

THERMOCOUPLE BASICS

Thermocouples are economical and rugged; they have reasonably good long-term stability. Because of their small size, they respond quickly and are good choices where fast response is important. They function over temperature ranges from cryogenics to jet-engine exhaust and have reasonable linearity and accuracy.

Because the number of free electrons in a piece of metal depends on both temperature and composition of the metal, two pieces of dissimilar metal in isothermal and contact will exhibit a potential difference that is a repeatable function of temperature, as shown in Figure 14. The resulting voltage depends on the temperatures, T1 and T2, in a repeatable way.

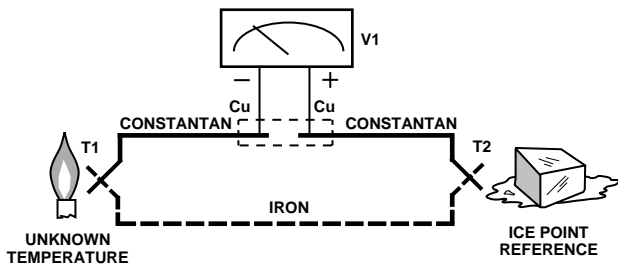

Figure 14. Thermocouple Voltage with 0°C Reference

Since the thermocouple is basically a differential rather than absolute measuring device, a known reference temperature is required for one of the junctions if the temperature of the other is to be inferred from the output voltage. Thermocouples made of specially selected materials have been exhaustively characterized in terms of voltage versus temperature compared to primary temperature standards. Most notably the water-ice point of 0°C is used for tables of standard thermocouple performance.

An alternative measurement technique, illustrated in Figure 15, is used in most practical applications where accuracy requirements do not warrant maintenance of primary standards. The reference junction temperature is allowed to change with the environment of the measurement system, but it is carefully measured by some type of absolute thermometer. A measurement of the thermocouple voltage combined with a knowledge of the reference temperature can be used to calculate the measurement junction temperature. Usual practice, however, is to use a convenient thermoelectric method to measure the reference temperature

and to arrange its output voltage so that it corresponds to a thermocouple referred to 0°C. This voltage is simply added to the thermocouple voltage and the sum then corresponds to the standard voltage tabulated for an ice-point referenced thermocouple.

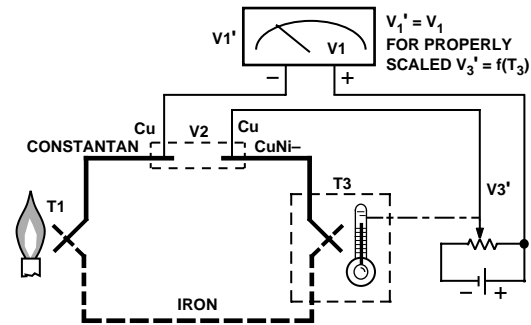

Figure 15. Substitution of Measured Reference Temperature for Ice Point Reference

The temperature sensitivity of silicon integrated circuit transistors is quite predictable and repeatable. This sensitivity is exploited in the AD594/AD595 to produce a temperature related voltage to compensate the reference of "cold" junction of a thermocouple as shown in Figure 16.

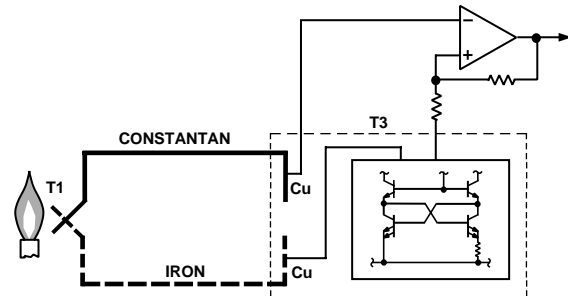

Figure 16. Connecting Isothermal Junctions

Since the compensation is at the reference junction temperature, it is often convenient to form the reference "junction" by connecting directly to the circuit wiring. So long as these connections and the compensation are at the same temperature no error will result.

OUTLINE DIMENSIONS

Dimensions shown in inches and (mm).

TO-116 (D) Package

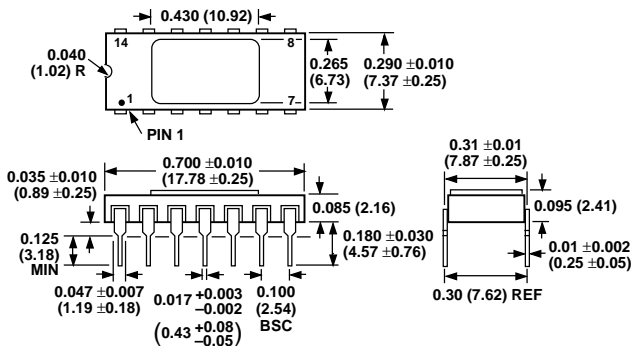

Cerdip (Q) Package

