

Electronic two-tone ringer

Features

- Low current consumption, in order to allow the parallel operation of 4 devices
- Integrated rectifier bridge with zener diodes to protect against over voltages little external circuitry
- Tone and switching frequencies adjustable by external components
- Integrated voltage and current hysteresis

Description

LS1240 is a monolithic integrated circuit designed to replace the mechanical bell in telephone sets in connection with an electro-acoustical converter. It can drive directly a piezoceramic converter (buzzer) or a dynamic loudspeaker.

The output current capability of LS1240 is higher than the one of a standard ringer. To drive a dynamic loudspeaker LS1240 can simply use a decoupling capacitor, thus eliminating the usual transformer.

No current limitation is provided on the output stage of LS1240, so a minimum load DC of 50 Ω is advised, in series with a proper capacitor.

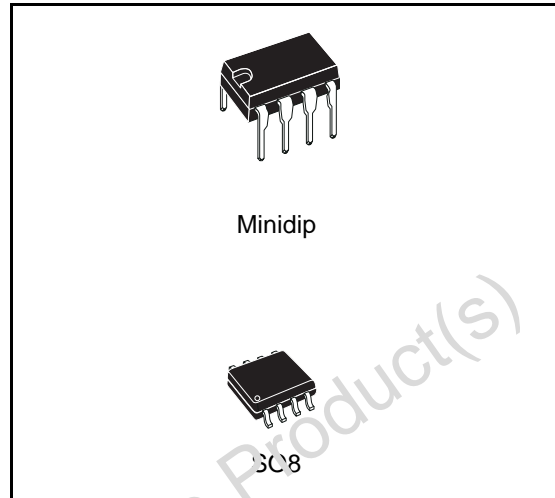

The two tone frequencies generated are switched by an internal oscillator in a fast sequence and are made audible across an output amplifier in the loudspeaker. Both tone frequencies and the switching frequency can be externally adjusted.

The supply voltage is obtained from the AC ring signal and the circuit is designed so that noise on the line or variations of the ringing signal cannot affect correct operation of the device.

Pin connection (top view)

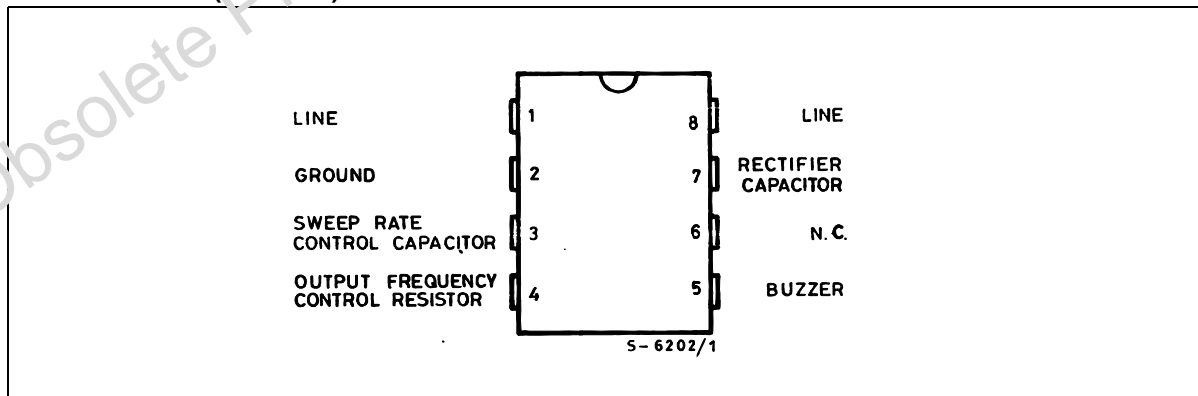

1 Block diagram and test circuit

Figure 1. LS1240 block diagram

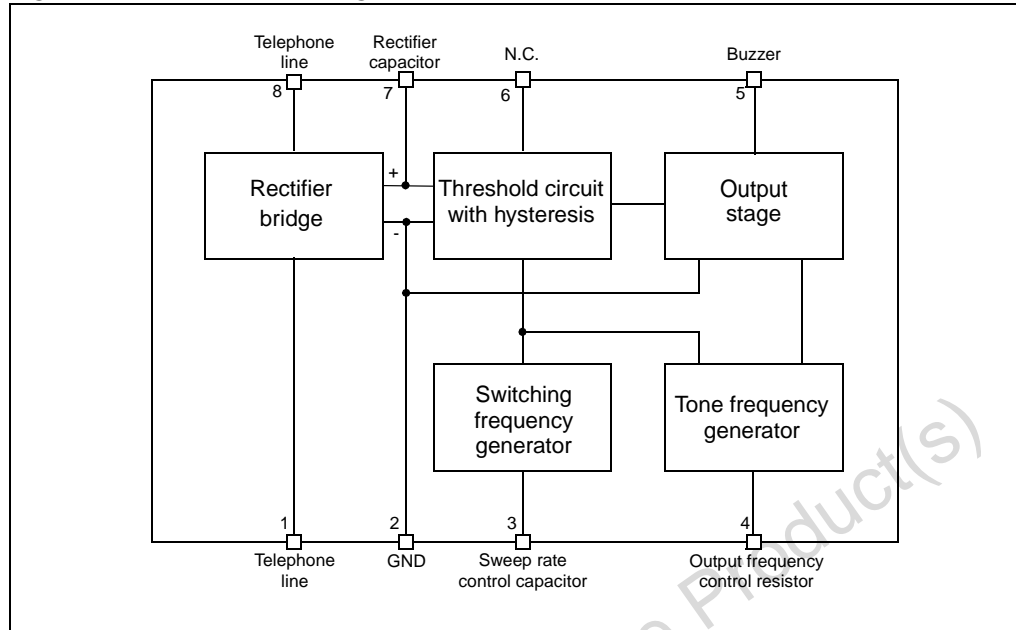
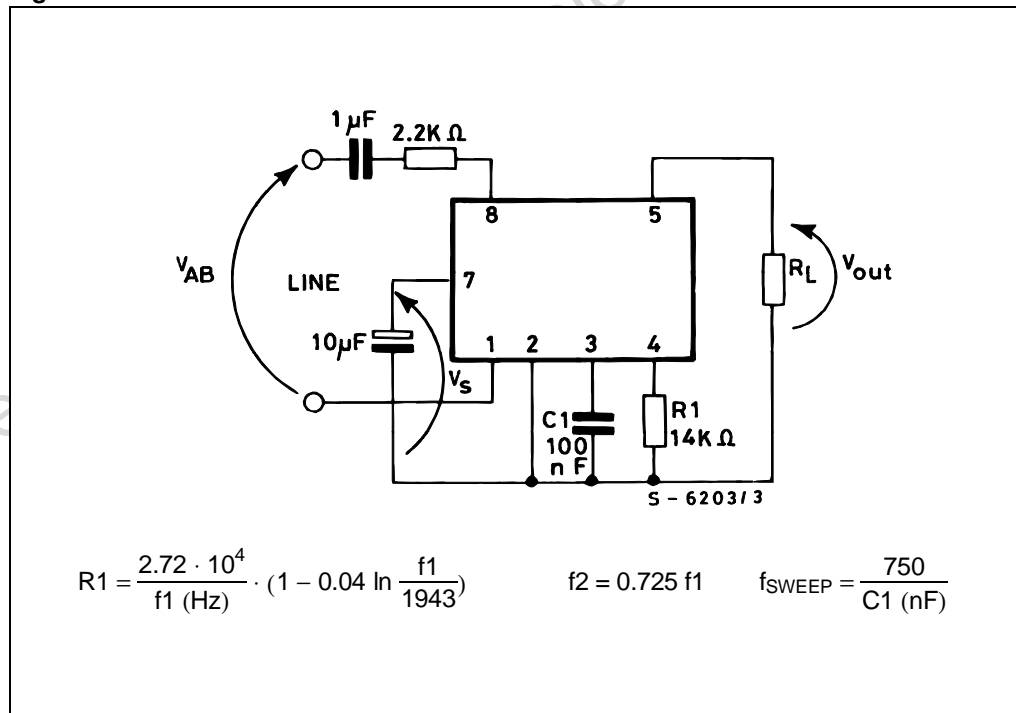

Figure 2. Test circuit



2 Electrical characteristics

Table 1. Absolute maximum ratings

| Symbol | Parameter | Value | Unit |
|------------------|---|-------------|------|
| V _{AB} | Calling voltage (f = 50 Hz) continuous | 120 | Vms |
| V _{AB} | Calling voltage (f = 50 Hz) 5s ON/10s OFF | 200 | Vms |
| DC | Supply current | 30 | mA |
| T _{OP} | Operating temperature | -40 to 70 | °C |
| T _{stg} | Storage and junction temperature | -65 to +150 | °C |

Table 2. Thermal data

| Symbol | Parameter | Value | Unit |
|----------------------|---|-------|------|
| R _{thj-amb} | Maximum thermal resistance junction-ambient | 100 | °C/W |

T_{amb} = 25°C, V_S = applied between pins 7-2 unless otherwise specified.

Table 3. Electrical characteristics

| Symbol | Parameter | Test conditions | Min. | Typ. | Max. | unit |
|---------------------|--|---|------|-------------------|------|------|
| V _S | Supply voltage | | | | 26 | V |
| I _B | Current consumption without load (pins 8-1) | V ₈₋₁ = 9.3 to 25 V | | 1.5 | 1.8 | mA |
| V _{ON} | Activation voltage | | 12.2 | | 13.2 | V |
| V _{OFF} | Sustaining voltage | | 8 | | 9 | V |
| R _D | Differential resistance in OFF conditions (pins 8-1) | | 6.4 | | | kΩ |
| V _{OUT} | Output voltage swing | | | V _S -5 | | V |
| I _{OUT} | Short circuit current (pins 5-2) | V _S = 20V R _L = 250Ω | | 70 | | mA |
| AC operation | | | | | | |
| | Output frequencies | V _S = 26V, R ₁ = 14Ω | | | | |
| f ₁ | f _{OUT1} | V _S = 0V | 1.74 | | 2.14 | kHz |
| f ₂ | f _{OUT2} | V _S = 6V | 1.22 | | 1.6 | |
| | f _{OUT1} f _{OUT2} | | 1.33 | | 1.43 | |
| | Programming resistor range | | 8 | | 56 | kW |
| | Sweep frequency | R ₁ = 14 kΩ, C ₁ = 100 nF | 5.25 | 7.5 | 9.75 | Hz |

3 Application schematics

Figure 3. Typical application with buzzer

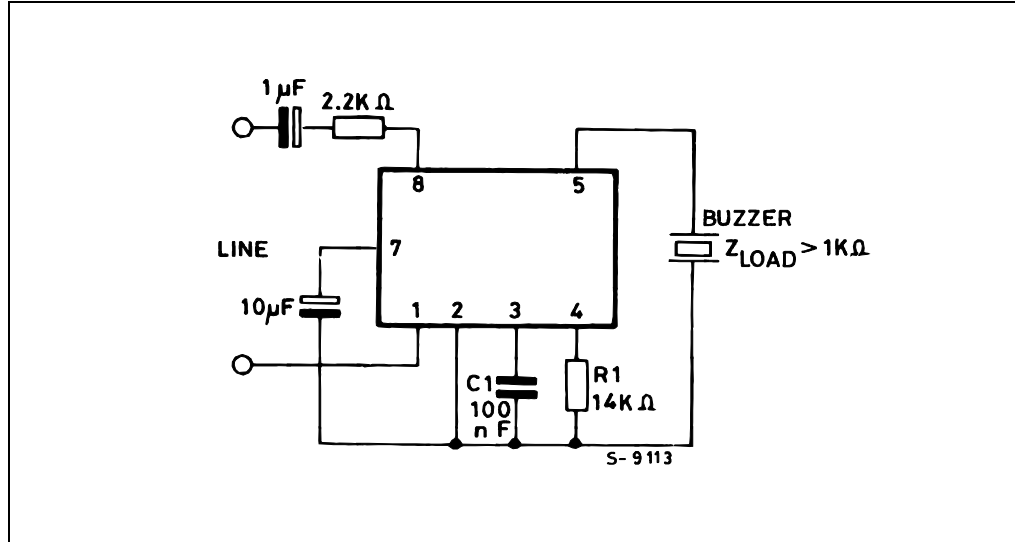
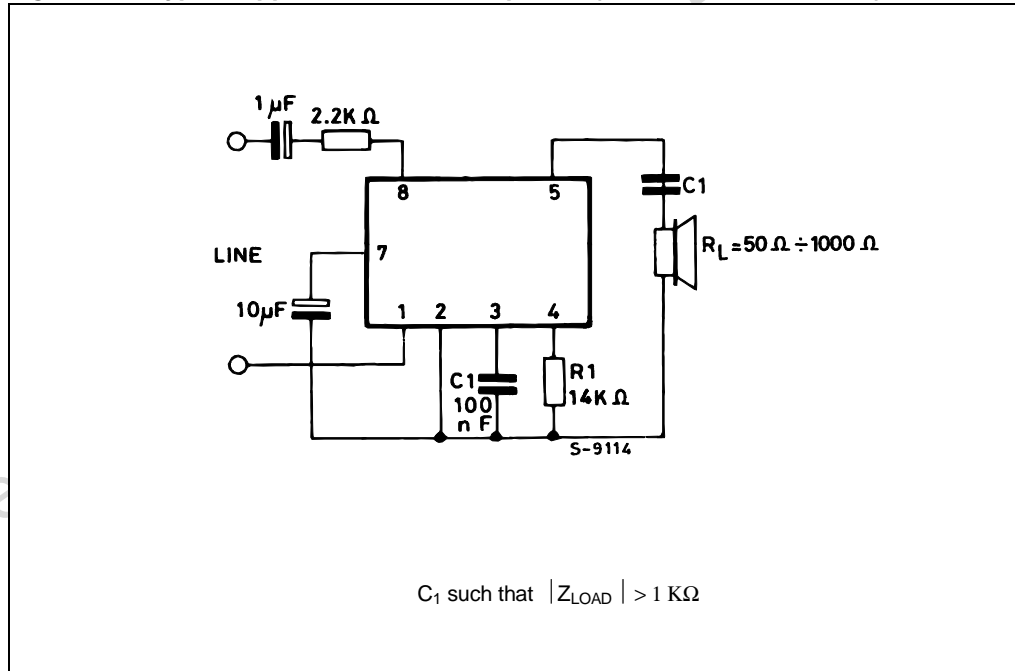

Figure 4. Typical application with loudspeaker (no transformer needed)



4 Package mechanical data

In order to meet environmental requirements, ST offers these devices in ECOPACK® packages. These packages have a Lead-free second level interconnect . The category of second Level Interconnect is marked on the package and on the inner box label, in compliance with JEDEC Standard JESD97. The maximum ratings related to soldering conditions are also marked on the inner box label. ECOPACK is an ST trademark. ECOPACK specifications are available at: www.st.com.

Obsolete Product(s) - Obsolete Product(s)

Table 4. Minidip package dimensions

| Dim. | mm | | | inch | | |
|------|-------|------|-------|-------|-------|-------|
| | Min. | Typ. | Max. | Min. | Typ. | Max. |
| A | | 3.32 | | | 0.131 | |
| a1 | 0.51 | | | 0.020 | | |
| B | 1.15 | | 1.65 | 0.045 | | 0.065 |
| b | 0.356 | | 0.55 | 0.014 | | 0.022 |
| b1 | 0.204 | | 0.304 | 0.008 | | 0.012 |
| D | | | 10.92 | | | 0.430 |
| E | 7.95 | | 9.75 | 0.313 | | 0.384 |
| e | | 2.54 | | | 0.100 | |
| e3 | | 7.62 | | | 0.300 | |
| e4 | | 7.62 | | | 0.300 | |
| F | | | 6.6 | | | 0.260 |
| I | | | 5.08 | | | 0.200 |
| L | 3.18 | | 3.81 | 0.125 | | 0.150 |
| Z | | | 1.52 | | | 0.060 |

Figure 5. Minidip package mechanical drawing

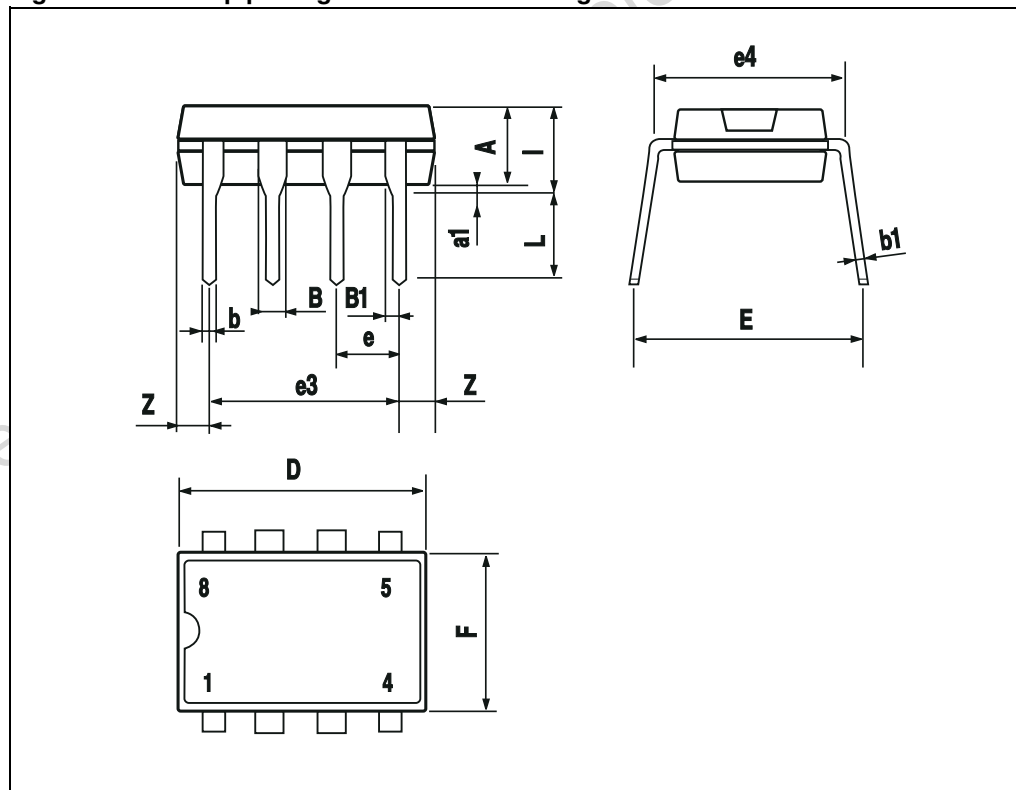
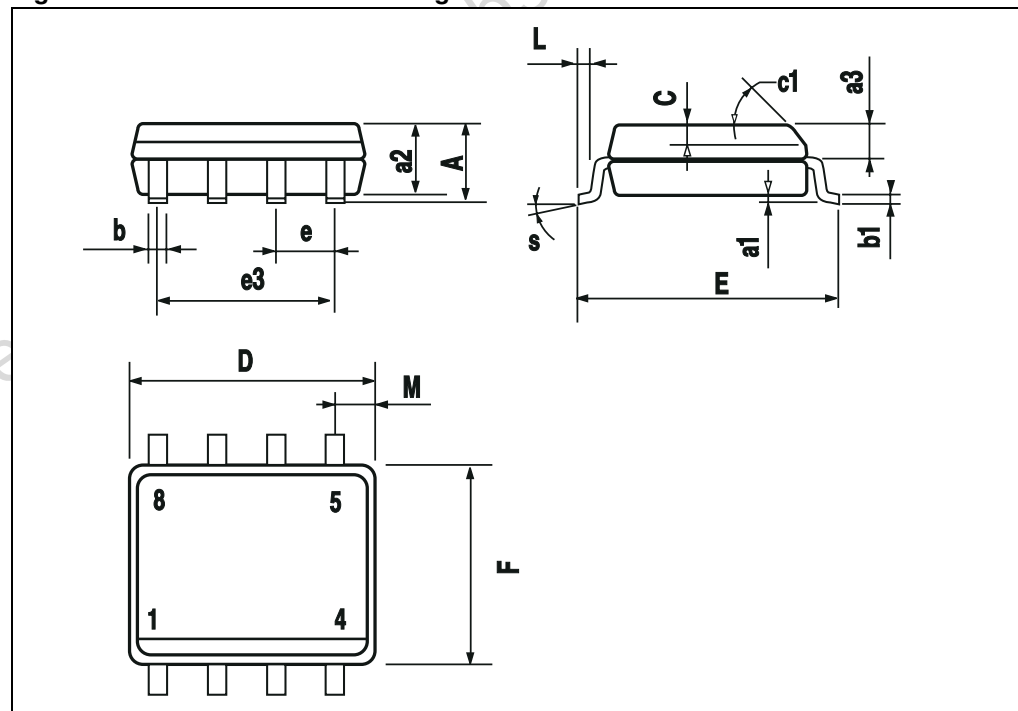

Table 5. SO8 package dimensions

| Dim. | mm | | | inch | | |
|------|------------|------|------|-------|-------|-------|
| | Min. | Typ. | Max. | Min. | Typ. | Max. |
| A | | | 1.75 | | | 0.069 |
| a1 | 0.1 | | 0.25 | 0.004 | | 0.010 |
| a2 | | | 1.65 | | | 0.065 |
| a3 | 0.65 | | 0.85 | 0.026 | | 0.033 |
| b | 0.35 | | 0.48 | 0.014 | | 0.019 |
| b1 | 0.19 | | 0.25 | 0.007 | | 0.010 |
| C | 0.25 | | 0.50 | 0.010 | | 0.020 |
| c1 | 45° (typ.) | | | | | |
| D(1) | 4.8 | | 5.0 | 0.189 | | 0.197 |
| E | 5.8 | | 6.2 | 0.228 | | 0.244 |
| e | | 1.27 | | | 0.050 | |
| e3 | | 3.81 | | | 0.150 | |
| F(1) | 3.8 | | 4.0 | 0.15 | | 0.157 |
| L | 0.4 | | 1.27 | 0.016 | | 0.050 |
| M | | | 0.6 | | | 0.024 |
| S | 8° (max.) | | | | | |

Figure 6. SO8 mechanical drawing



5 Ordering information

Table 6. Order codes

| Part number | Package |
|----------------------------|---------|
| LS1240A | Minidip |
| LS1240AD1 | SO8 |
| E-LS1240A ⁽¹⁾ | Minidip |
| E-LS1240AD1 ⁽¹⁾ | SO8 |

1. ECOPACK[®] (see [Chapter 4](#))

6 Revision history

Table 7. Document revision history

| Date | Revision | Changes |
|-------------|----------|--|
| 15-Jul-1998 | 1 | Initial release. |
| 23-Aug-2006 | 2 | Updated the document to reflect the fact that packages are leadfree and part numbers have changed. |

Please Read Carefully:

Information in this document is provided solely in connection with ST products. STMicroelectronics NV and its subsidiaries ("ST") reserve the right to make changes, corrections, modifications or improvements, to this document, and the products and services described herein at any time, without notice.

All ST products are sold pursuant to ST's terms and conditions of sale.

Purchasers are solely responsible for the choice, selection and use of the ST products and services described herein, and ST assumes no liability whatsoever relating to the choice, selection or use of the ST products and services described herein.

No license, express or implied, by estoppel or otherwise, to any intellectual property rights is granted under this document. If any part of this document refers to any third party products or services it shall not be deemed a license grant by ST for the use of such third party products or services, or any intellectual property contained therein or considered as a warranty covering the use in any manner whatsoever of such third party products or services or any intellectual property contained therein.

UNLESS OTHERWISE SET FORTH IN ST'S TERMS AND CONDITIONS OF SALE ST DISCLAIMS ANY EXPRESS OR IMPLIED WARRANTY WITH RESPECT TO THE USE AND/OR SALE OF ST PRODUCTS INCLUDING WITHOUT LIMITATION IMPLIED WARRANTIES OF MERCHANTABILITY, FITNESS FOR A PARTICULAR PURPOSE (AND THEIR EQUIVALENTS UNDER THE LAWS OF ANY JURISDICTION), OR INFRINGEMENT OF ANY PATENT, COPYRIGHT OR OTHER INTELLECTUAL PROPERTY RIGHT.

UNLESS EXPRESSLY APPROVED IN WRITING BY AN AUTHORIZED ST REPRESENTATIVE, ST PRODUCTS ARE NOT RECOMMENDED, AUTHORIZED OR WARRANTED FOR USE IN MILITARY, AIR CRAFT, SPACE, LIFE SAVING, OR LIFE SUSTAINING APPLICATIONS, NOR IN PRODUCTS OR SYSTEMS WHERE FAILURE OR MALFUNCTION MAY RESULT IN PERSONAL INJURY, DEATH, OR SEVERE PROPERTY OR ENVIRONMENTAL DAMAGE. ST PRODUCTS WHICH ARE NOT SPECIFIED AS "AUTOMOTIVE GRADE" MAY ONLY BE USED IN AUTOMOTIVE APPLICATIONS AT USER'S OWN RISK.

Resale of ST products with provisions different from the statements and/or technical features set forth in this document shall immediately void any warranty granted by ST for the ST product or service described herein and shall not create or extend in any manner whatsoever, any liability of ST.

ST and the ST logo are trademarks or registered trademarks of ST in various countries.

Information in this document supersedes and replaces all information previously supplied.

The ST logo is a registered trademark of STMicroelectronics. All other names are the property of their respective owners.

© 2006 STMicroelectronics - All rights reserved

STMicroelectronics group of companies

Australia - Belgium - Brazil - Canada - China - Czech Republic - Finland - France - Germany - Hong Kong - India - Israel - Italy - Japan - Malaysia - Malta - Morocco - Singapore - Spain - Sweden - Switzerland - United Kingdom - United States of America

www.st.com

