

### FEATURES

- Pin programmable 2.5 V or 3.0 V output**
- Ultralow drift: 3 ppm/°C max**
- High accuracy: 2.5 V or 3.0 V  $\pm 1$  mV max**
- Low noise: 100 nV/ $\sqrt{\text{Hz}}$**
- Noise reduction capability**
- Low quiescent current: 1 mA max**
- Output trim capability**
- Plug-in upgrade for present references**
- Temperature output pin**
- Series or shunt mode operation ( $\pm 2.5$  V,  $\pm 3.0$  V)**

### FUNCTIONAL BLOCK DIAGRAM

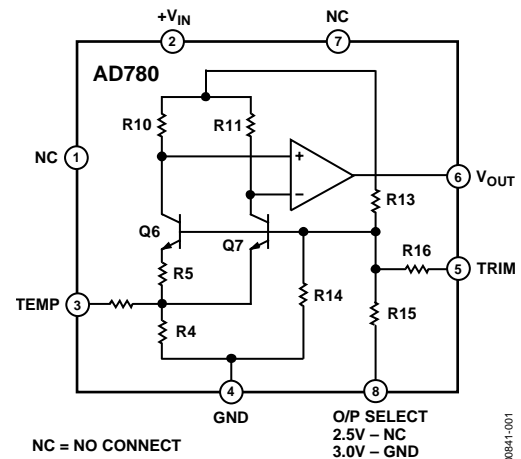

Figure 1.

### PRODUCT DESCRIPTION

The AD780 is an ultrahigh precision band gap reference voltage that provides a 2.5 V or 3.0 V output from inputs between 4.0 V and 36 V. Low initial error and temperature drift combined with low output noise and the ability to drive any value of capacitance make the AD780 the ideal choice for enhancing the performance of high resolution ADCs and DACs, and for any general-purpose precision reference application. A unique low headroom design facilitates a 3.0 V output from a 5.0 V 10% input, providing a 20% boost to the dynamic range of an ADC over performance with existing 2.5 V references.

The AD780 can be used to source or sink up to 10 mA, and can be used in series or shunt mode, thus allowing positive or negative output voltages without external components. This makes it suitable for virtually any high performance reference application. Unlike some competing references, the AD780 has no region of possible instability. The part is stable under all load conditions when a 1  $\mu\text{F}$  bypass capacitor is used on the supply.

A temperature output pin on the AD780 provides an output voltage that varies linearly with temperature, allowing the part to be configured as a temperature transducer while providing a stable 2.5 V or 3.0 V output.

The AD780 is a pin compatible performance upgrade for the LT1019(A)-2.5 and the AD680. The latter is targeted toward low power applications.

The AD780 is available in three grades in PDIP and SOIC packages. The AD780AN, AD780AR, AD780BN, AD780BR, and AD780CR are specified for operation from  $-40^\circ\text{C}$  to  $+85^\circ\text{C}$ .

### PRODUCT HIGHLIGHTS

1. The AD780 provides a pin programmable 2.5 V or 3.0 V output from a 4 V to 36 V input.
2. Laser trimming of both initial accuracy and temperature coefficients results in low errors over temperature without the use of external components. The AD780BN has a maximum variation of 0.9 mV from  $-40^\circ\text{C}$  to  $+85^\circ\text{C}$ .
3. For applications that require even higher accuracy, an optional fine-trim connection is provided.
4. The AD780 noise is extremely low, typically 4 mV p-p from 0.1 Hz to 10 Hz and a wideband spectral noise density of typically 100 nV/ $\sqrt{\text{Hz}}$ . This can be further reduced, if desired, by using two external capacitors.
5. The temperature output pin enables the AD780 to be configured as a temperature transducer while providing a stable output reference.

Information furnished by Analog Devices is believed to be accurate and reliable. However, no responsibility is assumed by Analog Devices for its use, nor for any infringements of patents or other rights of third parties that may result from its use. Specifications subject to change without notice. No license is granted by implication or otherwise under any patent or patent rights of Analog Devices. Trademarks and registered trademarks are the property of their respective owners.

## SPECIFICATIONS

$T_A = 25^\circ\text{C}$ ,  $V_{IN} = 5\text{ V}$ , unless otherwise noted.

Table 1.

Parameter	AD780AN/AD780AR			AD780CR			AD780BN/AD780BR			Unit
	Min	Typ	Max	Min	Typ	Max	Min	Typ	Max	
OUTPUT VOLTAGE										
2.5 V Out	2.495		2.505	2.4985		2.5015	2.499		2.501	V
3.0 V Out	2.995		3.005	2.9950		3.0050	2.999		3.001	V
OUTPUT VOLTAGE DRIFT <sup>1</sup>										
$-40^\circ\text{C}$ to $+85^\circ\text{C}$			7			7			3	ppm/ $^\circ\text{C}$
$-55^\circ\text{C}$ to $+125^\circ\text{C}$			20			20				ppm/ $^\circ\text{C}$
LINE REGULATION										
2.5 V Output, $4\text{ V} \leq V_{IN} \leq 36\text{ V}$ , $T_{MIN}$ to $T_{MAX}$			10			10			10	$\mu\text{V}/\text{V}$
3.0 V Output, $4.5\text{ V} \leq V_{IN} \leq 36\text{ V}$ , $T_{MIN}$ to $T_{MAX}$			10			10			10	$\mu\text{V}/\text{V}$
LOAD REGULATION, SERIES MODE										
Sourcing $0\text{ mA} < I_{OUT} < 10\text{ mA}$			50			50			50	$\mu\text{V}/\text{mA}$
$T_{MIN}$ to $T_{MAX}$			75			75			75	$\mu\text{V}/\text{mA}$
Sinking $-10\text{ mA} < I_{OUT} < 0\text{ mA}$			75			75			75	$\mu\text{V}/\text{mA}$
$-40^\circ\text{C}$ to $+85^\circ\text{C}$			75			75			75	$\mu\text{V}/\text{mA}$
$-55^\circ\text{C}$ to $+125^\circ\text{C}$			150			150			150	$\mu\text{V}/\text{mA}$
LOAD REGULATION, SHUNT MODE										
$I < I_{SHUNT} < 10\text{ mA}$			75			75			75	$\mu\text{V}/\text{mA}$
QUIESCENT CURRENT, 2.5 V SERIES MODE <sup>2</sup>										
$-40^\circ\text{C}$ to $+85^\circ\text{C}$		0.75	1.0		0.75	1.0		0.75	1.0	mA
$-55^\circ\text{C}$ to $+125^\circ\text{C}$		0.8	1.3		0.8	1.3		0.8	1.3	mA
MINIMUM SHUNT CURRENT		0.7	1.0		0.7	1.0		0.7	1.0	mA
OUTPUT NOISE										
0.1 Hz to 10 Hz		4			4			4		$\mu\text{V p-p}$
Spectral Density, 100 Hz		100			100			100		$\text{nV}/\sqrt{\text{Hz}}$
LONG-TERM STABILITY <sup>3</sup>		20			20			20		$\pm\text{ ppm}/1000\text{ Hr}$
TRIM RANGE	4.0			4.0			4.0			$\pm\%$
TEMPERATURE PIN										
Voltage Output @ $25^\circ\text{C}$	500	560	620	500	560	620	500	560	620	mV
Temperature Sensitivity		1.9			1.9			1.9		$\text{mV}/^\circ\text{C}$
Output Resistance		3			3			3		$\text{k}\Omega$
SHORT-CIRCUIT CURRENT TO GROUND		30			30			30		mA
TEMPERATURE RANGE										
Specified Performance (A, B, C)	-40		+85	-40		+85	-40		+85	$^\circ\text{C}$
Operating Performance (A, B, C) <sup>4</sup>	-55		+125	-55		+125	-55		+125	$^\circ\text{C}$

<sup>1</sup> Maximum output voltage drift is guaranteed for all packages.

<sup>2</sup> 3.0 V mode typically adds 100  $\mu\text{A}$  to the quiescent current. Also,  $I_q$  increases by 2  $\mu\text{A}/\text{V}$  above an input voltage of 5 V.

<sup>3</sup> The long-term stability specification is noncumulative. The drift in subsequent 1,000 hour periods is significantly lower than in the first 1,000 hour period.

<sup>4</sup> The operating temperature range is defined as the temperature extremes at which the device will still function. Parts may deviate from their specified performance outside their specified temperature range.

## ABSOLUTE MAXIMUM RATINGS

Table 2.

Parameter	Values
+V <sub>IN</sub> to Ground	36 V
TRIM Pin to Ground	36 V
TEMP Pin to Ground	36 V
Power Dissipation (25°C)	500 mW
Storage Temperature	-65°C to +150°C
Lead Temperature (Soldering 10 sec)	300°C
Output Protection	Output safe for indefinite short to ground and momentary short to V <sub>IN</sub> .
ESD Classification	Class 1 (1000 V)

Stresses above those listed under Absolute Maximum Ratings may cause permanent damage to the device. This is a stress rating only; functional operation of the device at these or any conditions above those indicated in the operational sections of this specification is not implied. Exposure to absolute maximum specifications for extended periods may affect device reliability.

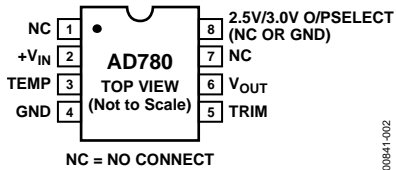

Figure 2. Pin Configuration, 8-Lead PDIP and SOIC Packages

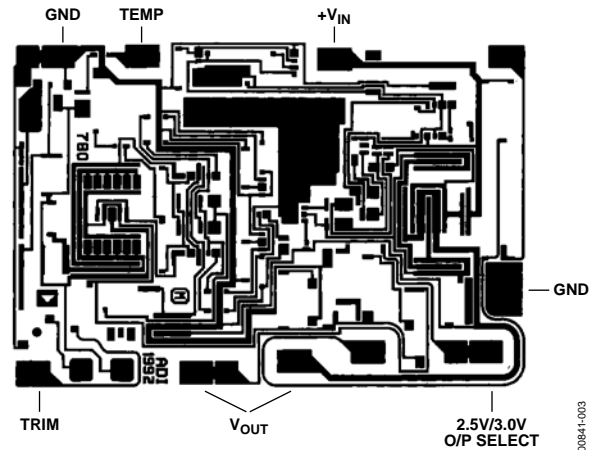

Figure 3. Die Layout

### NOTES

Both V<sub>OUT</sub> pads should be connected to the output.

**Die Thickness:** The standard thickness of Analog Devices bipolar dice is 24 mil ± 2 mil.

**Die Dimensions:** The dimensions given have a tolerance of ±2 mil.

**Backing:** The standard backside surface is silicon (not plated). Analog Devices does not recommend gold-backed dice for most applications.

**Edges:** A diamond saw is used to separate wafers into dice, thus providing perpendicular edges halfway through the die. In contrast to scribed dice, this technique provides a more uniform die shape and size. The perpendicular edges facilitate handling (such as tweezer pickup), while the uniform shape and size simplify substrate design and die attach.

**Top Surface:** The standard top surface of the die is covered by a layer of glassivation. All areas are covered except bonding pads and scribe lines.

**Surface Metallization:** The metallization to Analog Devices bipolar dice is aluminum. Minimum thickness is 10,000 Å.

**Bonding Pads:** All bonding pads have a minimum size of 4.0 mil by 6.0 mil. The passivation windows have a minimum size of 3.6 mil by 5.6 mil.

### ESD CAUTION

ESD (electrostatic discharge) sensitive device. Electrostatic charges as high as 4000 V readily accumulate on the human body and test equipment and can discharge without detection. Although this product features proprietary ESD protection circuitry, permanent damage may occur on devices subjected to high energy electrostatic discharges. Therefore, proper ESD precautions are recommended to avoid performance degradation or loss of functionality.



# OUTLINE DIMENSIONS

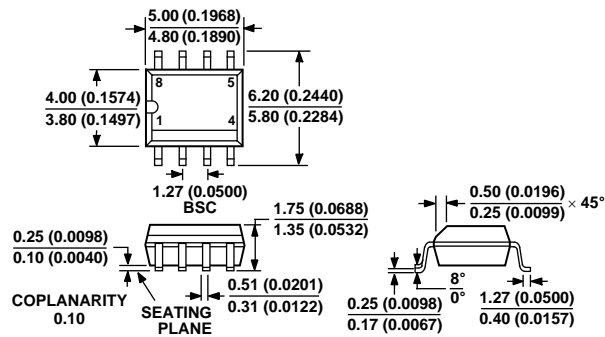

COMPLIANT TO JEDEC STANDARDS MS-012AA  
CONTROLLING DIMENSIONS ARE IN MILLIMETERS; INCH DIMENSIONS (IN PARENTHESES) ARE ROUNDED-OFF MILLIMETER EQUIVALENTS FOR REFERENCE ONLY AND ARE NOT APPROPRIATE FOR USE IN DESIGN

Figure 26. 8-Lead Standard Small Outline Package [SOIC]  
Narrow Body (R-8)  
Dimensions shown in millimeters and (inches)

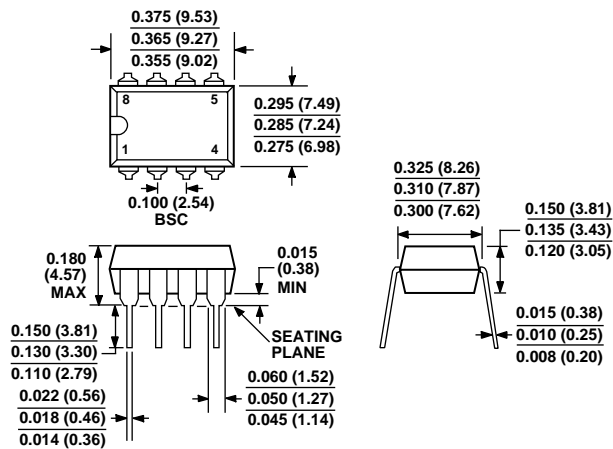

COMPLIANT TO JEDEC STANDARDS MO-095AA  
CONTROLLING DIMENSIONS ARE IN INCHES; MILLIMETER DIMENSIONS (IN PARENTHESES) ARE ROUNDED-OFF INCH EQUIVALENTS FOR REFERENCE ONLY AND ARE NOT APPROPRIATE FOR USE IN DESIGN

Figure 27. 8-Lead Plastic Dual-In-Line Package [PDIP]  
(N-8)  
Dimensions shown in inches and (millimeters)

# AD780

## ORDERING GUIDE

Model	Initial Error	Temperature Range	Temperature Coefficient	Package Option	Qty. per Tube/Reel
AD780AN	±5.0 mV	−40°C to +85°C	7 ppm/°C	PDIP	48
AD780AR	±5.0 mV	−40°C to +85°C	7 ppm/°C	SOIC	98
AD780AR-REEL7	±5.0 mV	−40°C to +85°C	7 ppm/°C	SOIC	750
AD780ARZ <sup>1</sup>	±5.0 mV	−40°C to +85°C	7 ppm/°C	SOIC	98
AD780BN	±1.0 mV	−40°C to +85°C	3 ppm/°C	PDIP	48
AD780BR	±1.0 mV	−40°C to +85°C	3 ppm/°C	SOIC	98
AD780BRZ <sup>1</sup>	±1.0 mV	−40°C to +85°C	3 ppm/°C	SOIC	98
AD780BR-REEL	±1.0 mV	−40°C to +85°C	3 ppm/°C	SOIC	2,500
AD780BR-REEL7	±1.0 mV	−40°C to +85°C	3 ppm/°C	SOIC	750
AD780BRZ <sup>1</sup>	±1.0 mV	−40°C to +85°C	3 ppm/°C	SOIC	98
AD780BRZ-REEL7 <sup>1</sup>	±1.0 mV	−40°C to +85°C	3 ppm/°C	SOIC	750
AD780CR	±1.5 mV	−40°C to +85°C	7 ppm/°C	SOIC	98
AD780CR-REEL7	±1.5 mV	−40°C to +85°C	7 ppm/°C	SOIC	750
AD780CRZ <sup>1</sup>	±1.5 mV	−40°C to +85°C	7 ppm/°C	SOIC	98

<sup>1</sup> Z = Pb-free part.

