

SLA7024M, SLA7026M, AND SMA7029M

HIGH-CURRENT PWM, UNIPOLAR STEPPER MOTOR CONTROLLER/DRIVERS

The SLA7024M, SLA7026M, and SMA7029M are designed for high-efficiency and high-performance operation of 2-phase, unipolar stepper motors. An automated, innovative packaging technology combined with power FETs and monolithic logic/control circuitry advances power multi-chip modules (PMCMs™) toward the complete integration of motion control. Highly automated manufacturing techniques provide low-cost and exceptionally reliable PMCMs suitable for controlling and directly driving a broad range of 2-phase, unipolar stepper motors. The three stepper motor multi-chip modules differ primarily in output current ratings (1.5 A or 3.0 A) and package style.

All three PMCMs are rated for an absolute maximum limit of 46 V and utilize advanced NMOS FETs for the high-current, high-voltage driver outputs. The avalanche-rated (≥ 100 V) FETs provide excellent ON resistance, improved body diodes, and very-fast switching. The multi-chip ratings and performance afford significant benefits and advantages for stepper drives when compared to the higher dissipation and slower switching speeds associated with bipolar transistors. Normally, heat sinks are not required for the SLA7024M or SMA7029M. The SLA7026M, in demanding, higher-current systems designs, necessitates suitable heat transfer methods for reliable operation.

Complete applications information is given on the following pages. PWM current is regulated by appropriately choosing current-sensing resistors, a voltage reference, a voltage divider, and RC timing networks. The RC components limit the OFF interval and control current decay. Inputs are compatible with 5 V logic and microprocessors.

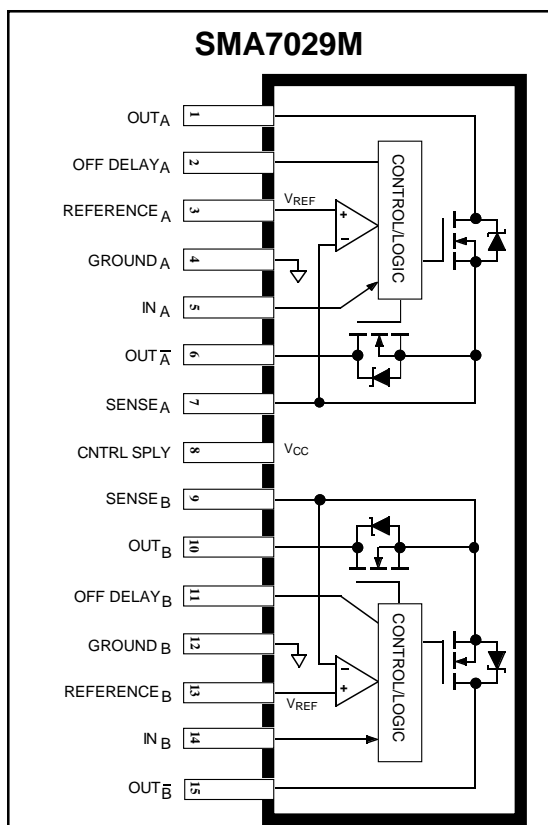

Dwg. PK-007

ABSOLUTE MAXIMUM RATINGS at $T_A = +25^\circ\text{C}$

Load Supply Voltage, V_{BB}	46 V
FET Output Voltage, V_{DS}	100 V
Control Supply Voltage, V_{CC}	46 V
Peak Output Current, I_{OUTM} ($t_w \leq 100 \mu\text{s}$)	
SLA7024M	3.0 A
SLA7026M	5.0 A
SMA7029M	3.0 A
Continuous Output Current, I_{OUT}	
SLA7024M	1.5 A
SLA7026M	3.0 A
SMA7029M	1.5 A
Input Voltage Range, V_{IN}	-0.3 V to 7.0 V
Reference Voltage, V_{REF}	2.0 V
Package Power Dissipation, P_D	See Graph
Junction Temperature, T_J	+150°C
Operating Temperature Range,	
T_A	-20°C to +85°C
Storage Temperature Range,	
T_{stg}	-40°C to +150°C

BENEFITS AND FEATURES

- Cost-Effective, Multi-Chip Solution
- 'Turn-Key' Motion-Control Module
- Motor Operation to 3 A and 46 V
- 3rd Generation High-Voltage FETs
- 100 V, Avalanche-Rated NMOS
- Low $r_{DS(on)}$ NMOS Outputs
- Advanced, Improved Body Diodes
- Single-Supply Motor/Module Operation
- Half- or Full-Step Unipolar Drive
- High-Efficiency, High-Speed PWM
- Dual PWM Current Control (2-Phase)
- Programmable PWM Current Control
- Low Component Count PWM Drive
- Low Internal Power Dissipation
- Heat Sinking (Normally) Unnecessary
- Electrically Isolated Power Tab
- Logic IC- and μP -Compatible Inputs
- Machine-Insertable Package

Always order by complete part number:

Part Number	Package	Output Current
SLA7024M	18-Lead Power-Tab SIP	1.5 A
SLA7026M	18-Lead Power-Tab SIP	3.0 A
SMA7029M	15-Lead SIP	1.5 A



SLA7024M, SLA7026M, AND SMA7029M HIGH-CURRENT PWM, UNIPOLAR STEPPER MOTOR CONTROLLER/DRIVERS

SLA7024M and SLA7026M FUNCTIONAL BLOCK DIAGRAM

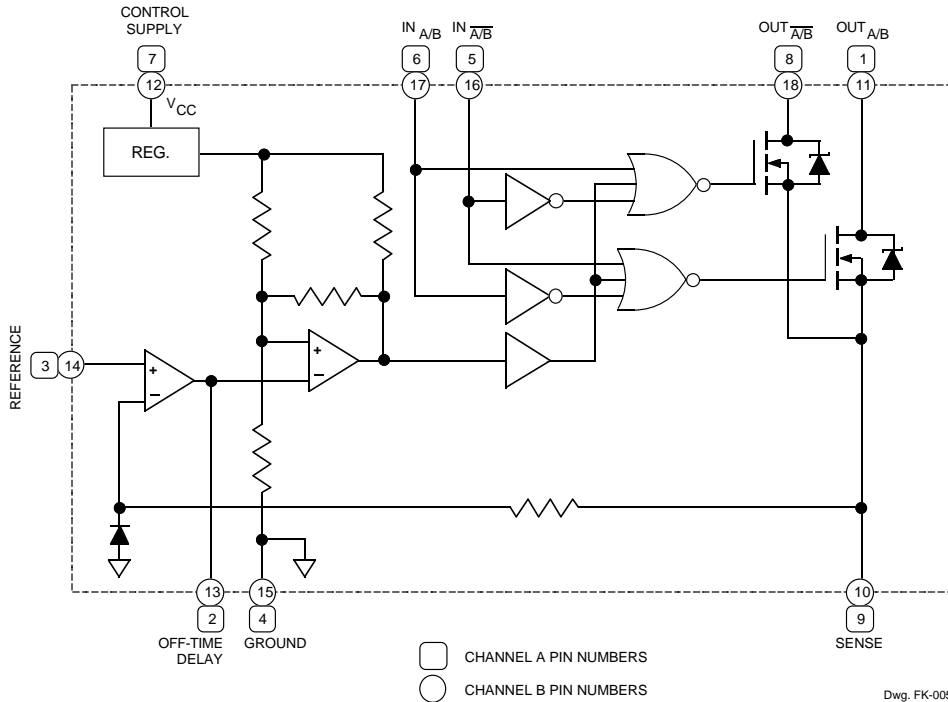

Note that channels A and B are electrically isolated.

SMA7029M FUNCTIONAL BLOCK DIAGRAM

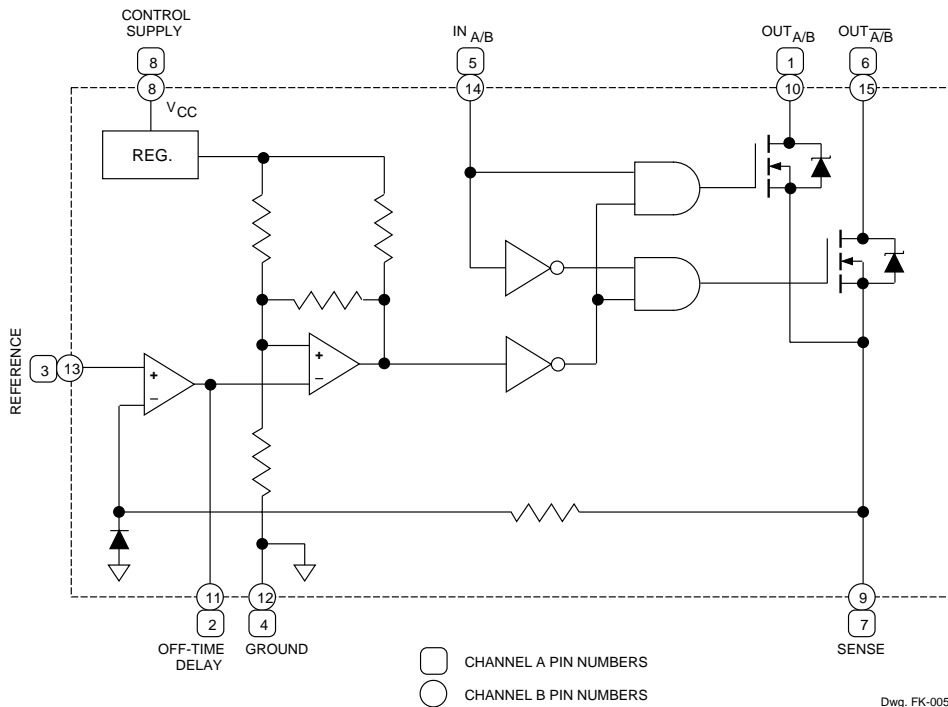

Note that except for the control supply, channels A and B are electrically isolated.

SLA7024M, SLA7026M, AND SMA7029M HIGH-CURRENT PWM, UNIPOLAR STEPPER MOTOR CONTROLLER/DRIVERS

ALLOWABLE PACKAGE POWER DISSIPATION

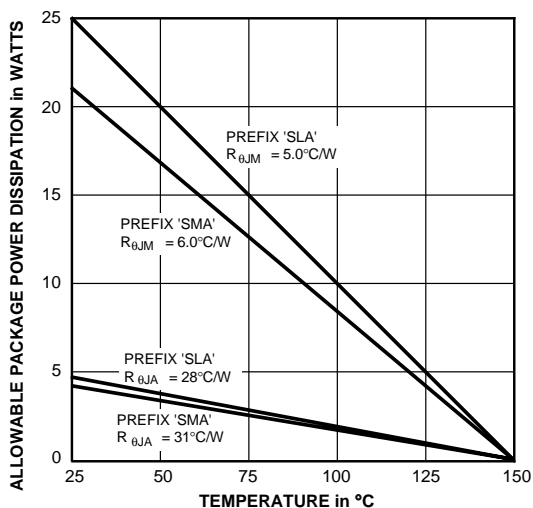

Dwg. GK-018

SLA7024M and SLA7026M

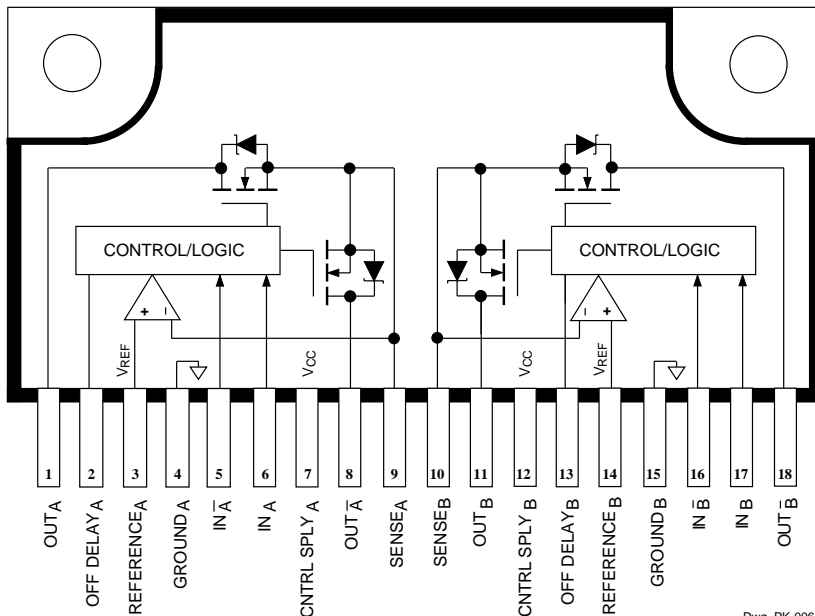

Dwg. PK-006

ELECTRICAL CHARACTERISTICS at $T_A = +25^{\circ}\text{C}$

Characteristic	Symbol	Test Conditions	Limits			Units
			Min	Typ	Max	
FET Leakage Current	I_{DSS}	$V_{DS} = 100\text{ V}, V_{CC} = 44\text{ V}$	—	—	4.0	mA
FET ON Voltage	$V_{DS(ON)}$	(SLA7024M & SMA7029M) $V_{CC} = 14\text{ V}, I_{OUT} = 1\text{ A}$	—	—	600	mV
		(SLA7026M) $V_{CC} = 14\text{ V}, I_{OUT} = 3\text{ A}$	—	—	850	mV
FET ON Resistance	$r_{DS(on)}$	(SLA7024M & SMA7029M) $V_{CC} = 14\text{ V}, I_{OUT} = 1\text{ A}$	—	—	600	m Ω
		(SLA7026M) $V_{CC} = 14\text{ V}, I_{OUT} = 3\text{ A}$	—	—	285	m Ω
Body Diode	V_{SD}	(SLA7024M & SMA7029M) $I_{OUT} = -1\text{ A}$	—	0.9	1.5	V
Forward Voltage		(SLA7026M) $I_{OUT} = -3\text{ A}$	—	0.9	1.6	V
Control Supply Voltage	V_{CC}	Operating	10	24	44	V
Control Supply Current	I_{CC}	$V_{CC} = 44\text{ V}$	—	10	15	mA
Input Current	$I_{IN(H)}$	$V_{CC} = 44\text{ V}, V_{IN} = 2.4\text{ V}$	—	—	40	μA
	$I_{IN(L)}$	$V_{IN} = 0.4\text{ V}$	—	—	-800	μA
Input Voltage	$V_{IN(H)}$		2.0	—	—	V
	$V_{IN(L)}$		—	—	0.8	V

NOTE: Negative current is defined as coming out of (sourcing) the specified device pin.

SLA7024M, SLA7026M, AND SMA7029M HIGH-CURRENT PWM, UNIPOLAR STEPPER MOTOR CONTROLLER/DRIVERS

TYPICAL STEPPER MOTOR APPLICATIONS (Half of Each Device Shown) SLA7024M and SLA7026M

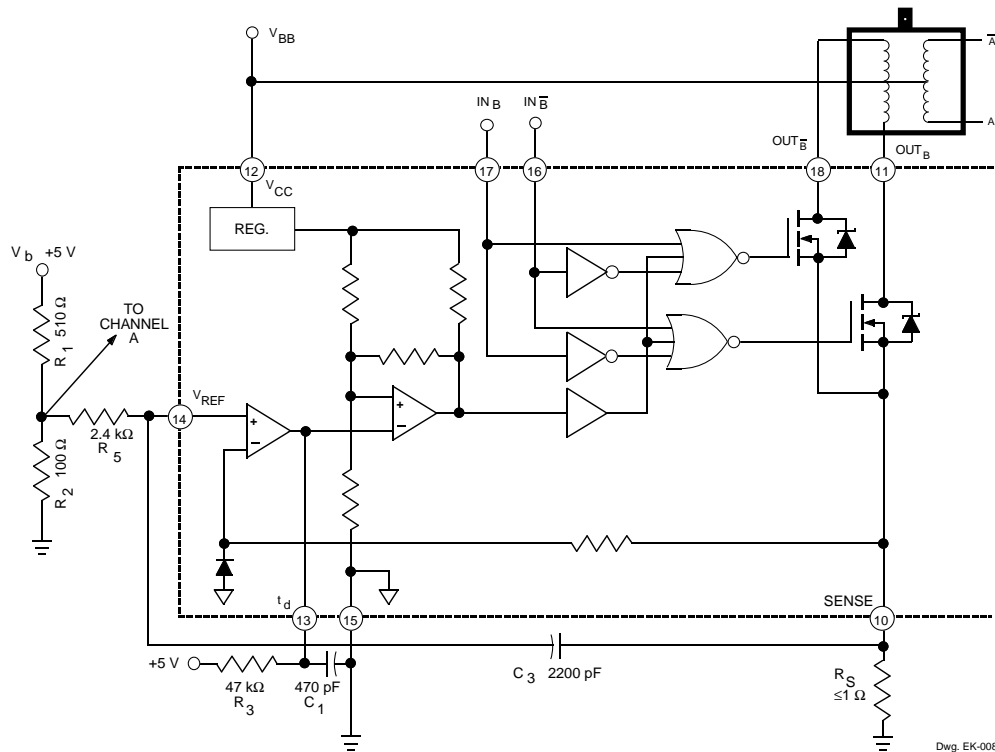

TRUTH TABLES (Device Types as Designated)

WAVE DRIVE (FULL STEP) for SLA7024M and SLA7026M

Sequence	0	1	2	3	0
Input A	H	L	L	L	H
Input \bar{A}	L	L	H	L	L
Input B	L	H	L	L	L
Input \bar{B}	L	L	L	H	L
Output ON	A	B	\bar{A}	\bar{B}	A

2-PHASE (FULL STEP) OPERATION for SLA7024M and SLA7026M

Sequence	0	1	2	3	0
Input A	H	L	L	H	H
Input \bar{A}	L	H	H	L	L
Input B	H	H	L	L	H
Input \bar{B}	L	L	H	H	L
Outputs ON	AB	$\bar{A}B$	$\bar{A}\bar{B}$	$A\bar{B}$	AB

HALF-STEP OPERATION (2-1-2 SEQUENCE) for SLA7024M, SLA7026M, and SMA7029M

Sequence	0	1	2	3	4	5	6	7	0
Input A	H	H	L	L	L	L	L	H	H
Input \bar{A} or t_{dA} *	L	L	L	H	H	H	L	L	L
Input B	L	H	H	H	L	L	L	L	L
Input \bar{B} or t_{dB} *	L	L	L	L	L	H	H	H	L
Output(s) ON	A	AB	B	$\bar{A}B$	\bar{A}	$\bar{A}\bar{B}$	\bar{B}	$A\bar{B}$	A

*Logic signals to external open-collector inverter connected to t_{dA} and t_{dB} .

SLA7024M, SLA7026M, AND SMA7029M HIGH-CURRENT PWM, UNIPOLAR STEPPER MOTOR CONTROLLER/DRIVERS

TYPICAL STEPPER MOTOR APPLICATIONS (Half of Device Shown) SMA7029M

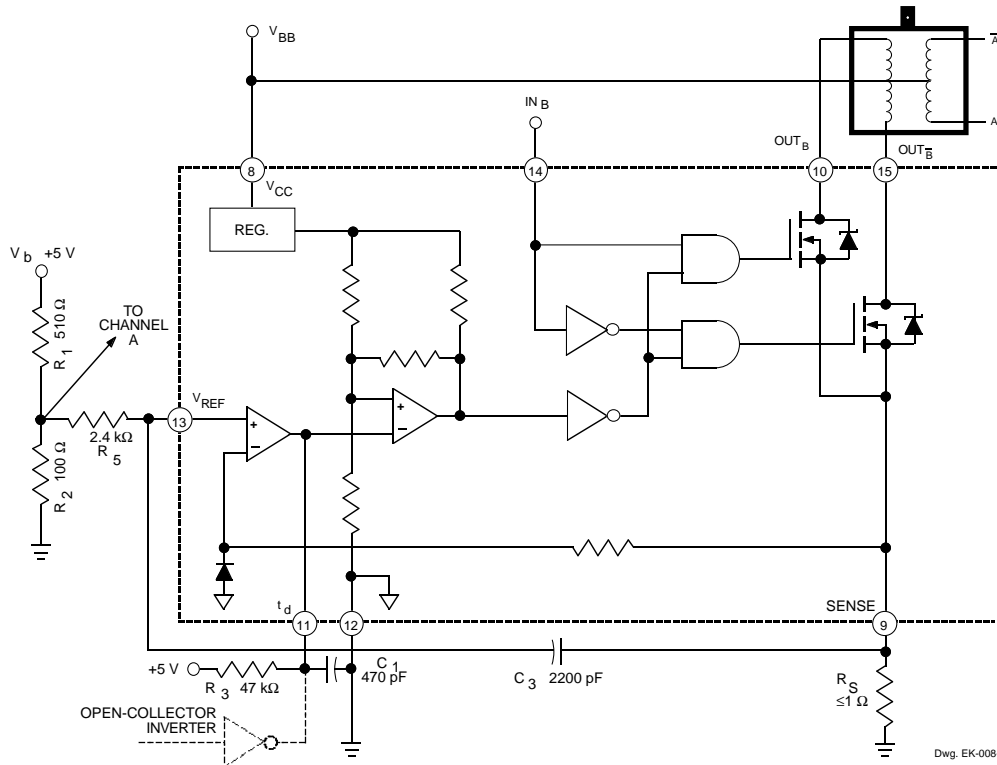

TRUTH TABLES (SMA7029M Only)

WAVE DRIVE (FULL STEP) for SMA7029M

Sequence	0	1	2	3	0
Input A	H	L	L	L	H
Input t _{dA} *	L	L	H	L	L
Input B	L	H	L	L	L
Input t _{dB} *	L	L	L	H	L
Output ON	A	B	\bar{A}	\bar{B}	A

*Logic signals to external open-collector inverter connected to t_{dA} and t_{dB}.

2- PHASE (FULL STEP) OPERATION for SMA7029M

Sequence	0	1	2	3	0
Input A	H	H	L	L	H
Input B	\bar{L}	H	\bar{H}	\bar{L}	\bar{L}
Outputs ON	$\bar{A} \bar{B}$	AB	$\bar{A} B$	$\bar{A} \bar{B}$	A B

Dwg. EK-008-1

SLA7024M, SLA7026M, AND SMA7029M HIGH-CURRENT PWM, UNIPOLAR STEPPER MOTOR CONTROLLER/DRIVERS

APPLICATIONS INFORMATION

REGULATING THE PWM OUTPUT CURRENT

The output current (and motor coil current) waveform is illustrated in Figure 1. Setting the PWM current trip point requires various external components:

V_b = Reference supply (typically 5 V)

R_1, R_2 = Voltage-divider resistors in the reference supply circuit

R_S = Current sensing resistor(s)

NOTE: The maximum allowable V_{REF} input voltage is 2.0 V. The voltage-divider must be selected accordingly.

Normal PWM (Full-Current/Running) Mode

I_{OUT} is set to meet the specified running current for the motor (Figure 2) and is determined by:

$$I_{OUT} \approx \frac{V_{REF}}{R_S} \quad (1)$$

or, if V_{REF} is not known

$$I_{OUT} \approx \frac{R_2}{R_1 + R_2} \cdot \frac{V_b}{R_S} \quad (2)$$

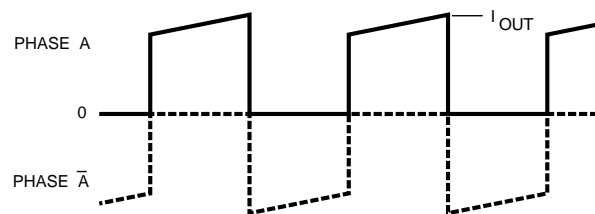

Dwg. WK-001

FIGURE 1. PHASE A COIL CURRENT WAVEFORM

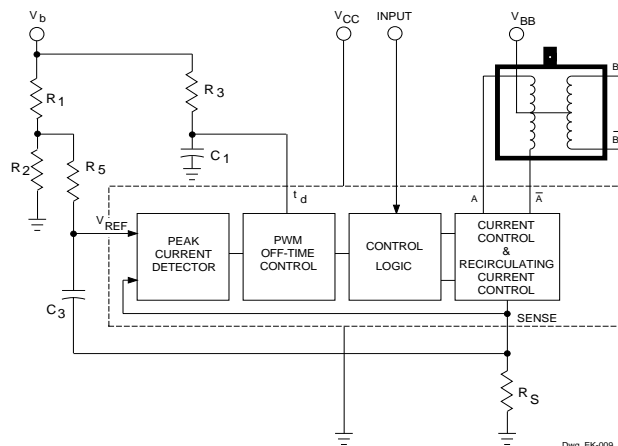

Dwg. EK-009

FIGURE 2. PWM CONTROL (RUN MODE)

SLA7024M, SLA7026M, AND SMA7029M HIGH-CURRENT PWM, UNIPOLAR STEPPER MOTOR CONTROLLER/DRIVERS

For given values of R_1 , R_2 , and V_b ($V_{REF} \approx 0.82$ V), Figure 3 illustrates output current as a function of current-sensing resistance (R_S).

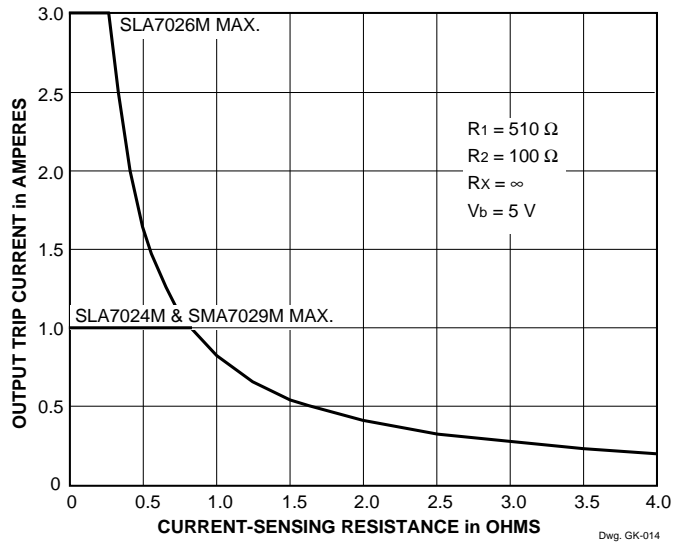

FIGURE 3. CURRENT-SENSING RESISTANCE

Reduced/Holding Current Mode

Additional circuitry (Figure 4) enables reducing motor current. The external transistor changes the voltage-divider ratio, V_{REF} , and reduces the output current. I_{HOLD} is determined by resistors R_2 and R_X in parallel:

$$I_{HOLD} \approx \frac{R_2 R_X}{R_1 R_2 + R_1 R_X + R_2 R_X} \cdot \frac{V_b}{R_S} \quad (3)$$

or

$$I_{HOLD} \approx \frac{R_2 \tilde{R}}{R_1 + R_2 \tilde{R}} \cdot \frac{V_b}{R_S} \quad (4)$$

where $R_2 \tilde{R}$ = the equivalent value of R_2 and R_X in parallel.

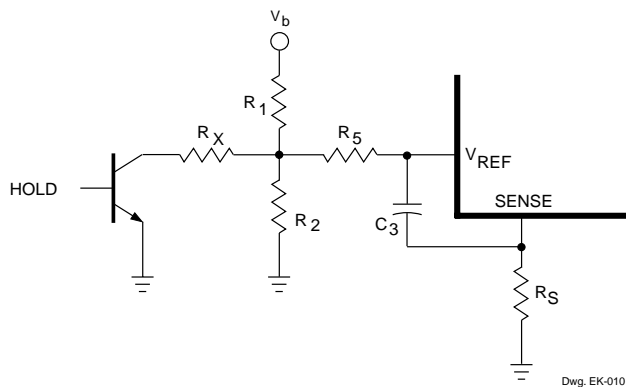

FIGURE 4. HOLD CURRENT MODE

SLA7024M, SLA7026M, AND SMA7029M HIGH-CURRENT PWM, UNIPOLAR STEPPER MOTOR CONTROLLER/DRIVERS

For given values of R_1 , R_2 , and V_b ($V_{REF} \approx 0.82\text{ V}$), Figures 5A and 5B illustrate output holding current as a function of R_x for two values of current-sensing resistance (R_s).

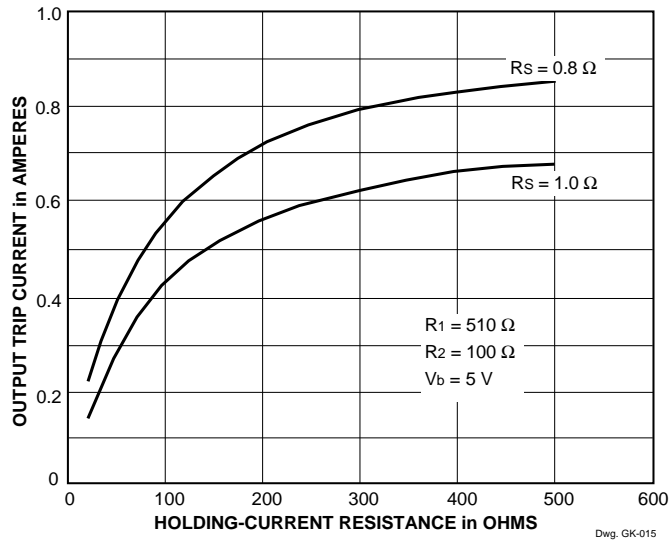

FIGURE 5A. HOLD-CURRENT RESISTANCE (SLA7024M and SMA7029M)

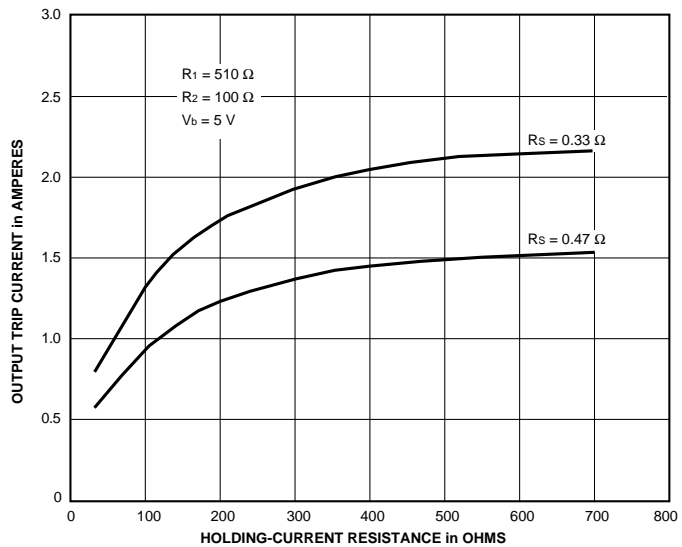

FIGURE 5B. HOLD-CURRENT RESISTANCE (SLA7026M)

NOTE: Holding current determines holding torque, which is normally greater than running torque. Consult motor manufacturer for recommended safe holding current and motor winding temperature limits in “standstill” or “detent” mode.

The MOSFET outputs create ringing noise with PWM, but the RC filter precludes malfunctions. The comparator operation is affected by R_5 and C_3 and, thus, current overshoot is influenced by component values. Empirical adjustment to “fine-tune” the current limit is likely.

SLA7024M, SLA7026M, AND SMA7029M HIGH-CURRENT PWM, UNIPOLAR STEPPER MOTOR CONTROLLER/DRIVERS

DETERMINING THE MOTOR PWM FREQUENCY

The modules function asynchronously, with PWM OFF time fixed by R_3 and C_1 at input t_d . The OFF time can be calculated as:

$$t_{OFF} \approx -R_3 \cdot C_1 \cdot \log_n \left(1 - \frac{2}{V_b}\right) \quad (5)$$

Recommended circuit constants and t_{OFF} are:

$$\begin{aligned} V_b &= 5 \text{ V} \\ R_3 &= 47 \text{ k}\Omega \\ C_1 &= 470 \text{ pF} \\ t_{OFF} &= 12 \text{ }\mu\text{s} \end{aligned}$$

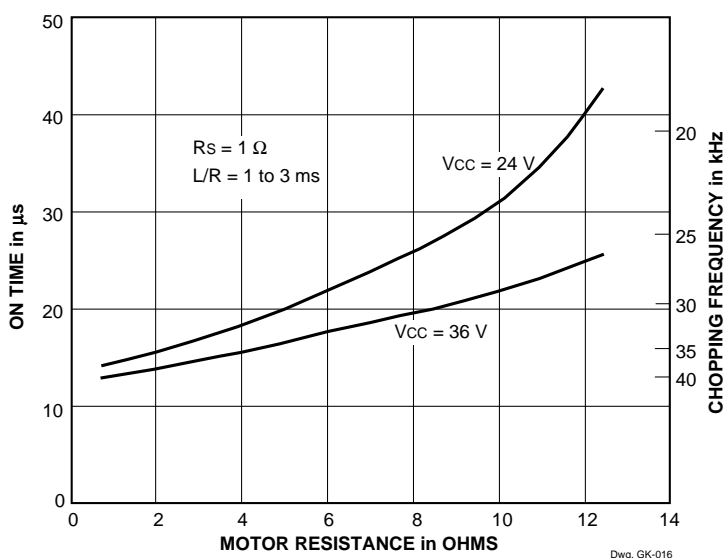

FIGURE 7.
PWM FREQUENCY vs MOTOR RESISTANCE

POWER DISSIPATION CALCULATIONS

Excepting high-current applications utilizing the SLA7026M above approximately 2.0 A at +65°C (with 2-phase operation), the need for heat sinks is rare. The basic constituents of conduction losses (internal power dissipation) include:

- (a) FET output power dissipation ($I_{OUT}^2 \cdot r_{DS(on)}$ or $I_{OUT} \cdot V_{DS(ON)}$),
- (b) FET body diode power dissipation ($V_{SD} \cdot I_{OUT}$), and
- (c) control circuit power dissipation ($V_{CC} \cdot I_{CC}$).

Device conduction losses are calculated based on the operating mode (wave drive, half-step, or 2-phase). Assuming a 50% output duty cycle:

$$\begin{aligned} \text{Wave Drive} &= 0.5 (I_{OUT}^2 \cdot r_{DS(on)}) + 0.5 (V_{SD} \cdot I_{OUT}) + (V_{CC} \cdot 15 \text{ mA}) \\ \text{Half-Step} &= 0.75 (I_{OUT}^2 \cdot r_{DS(on)}) + 0.75 (V_{SD} \cdot I_{OUT}) + (V_{CC} \cdot 15 \text{ mA}) \\ \text{2-Phase} &= (I_{OUT}^2 \cdot r_{DS(on)}) + (V_{SD} \cdot I_{OUT}) + (V_{CC} \cdot 15 \text{ mA}) \end{aligned}$$

SLA7024M, SLA7026M, AND SMA7029M HIGH-CURRENT PWM, UNIPOLAR STEPPER MOTOR CONTROLLER/DRIVERS

PACKAGE RATINGS/DERATING FACTORS

Thermal ratings/deratings for the multi-chip module packages vary slightly. Normally, the SLA7024M and SMA7029M do not need heat sinking when operated within maximum specified output current (≤ 1.0 A with 2-phase drive) unless the design ambient temperature also exceeds $+60^{\circ}\text{C}$. Thermal calculations must also consider the temperature effects on the output FET ON resistance. The applicable thermal ratings for the PMCM packages are:

SLA7024M and SLA7026M 18-Lead Power-Tab SIP

$R_{\Theta JA} = 28^{\circ}\text{C/W}$ (no heat sink) or 4.5 W at $+25^{\circ}\text{C}$ and a derating factor of -36 mW/ $^{\circ}\text{C}$ for operation above $+25^{\circ}\text{C}$. $R_{\Theta JC} = 5^{\circ}\text{C/W}$.

SMA7029M 15-Lead SIP

$R_{\Theta JA} = 31^{\circ}\text{C/W}$ (no heat sink) or 4.0 W at $+25^{\circ}\text{C}$ and a derating factor of -32 mW/ $^{\circ}\text{C}$ for operation above $+25^{\circ}\text{C}$. $R_{\Theta JC} = 6^{\circ}\text{C/W}$.

TEMPERATURE EFFECTS ON FET $r_{DS(on)}$

Analyzing safe, reliable operation includes a concern for the relationship of NMOS ON resistance to junction temperature. Device package power calculations must include the increase in ON resistance (producing higher output ON voltages) caused by higher operating junction temperatures. Figure 8 provides a normalized ON resistance curve, and all thermal calculations should consider increases from the given $+25^{\circ}\text{C}$ limits, which may be caused by internal heating during normal operation.

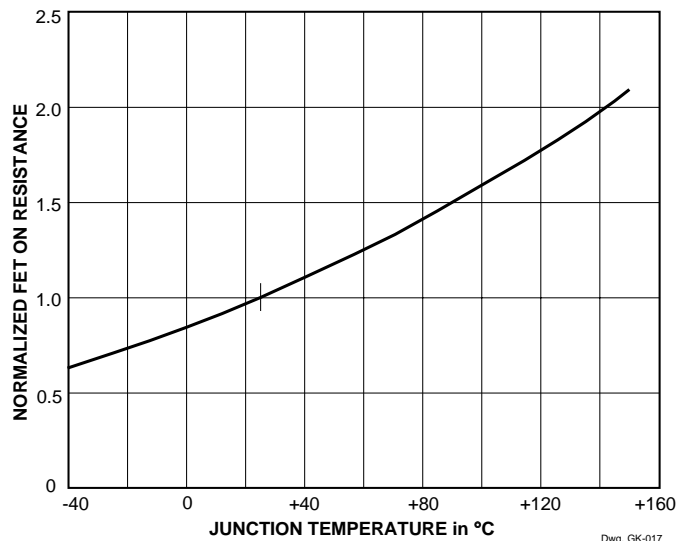
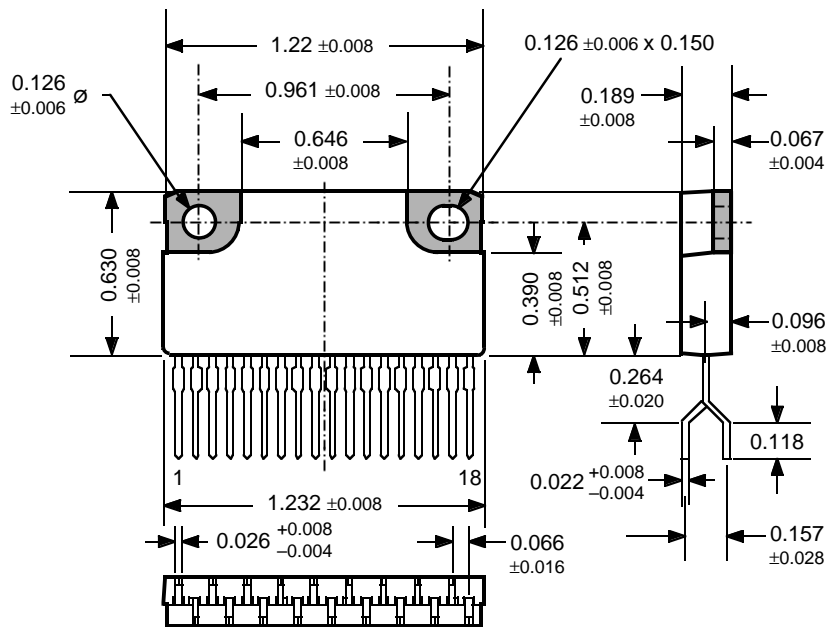

FIGURE 8. NORMALIZED ON RESISTANCE
vs TEMPERATURE

**SLA7024M, SLA7026M, AND SMA7029M
HIGH-CURRENT PWM,
UNIPOLAR STEPPER MOTOR
CONTROLLER/DRIVERS**

SLA7024M and SLA7026M

Dimensions in Inches
(for reference only)



Dimensions in Millimeters
(controlling dimensions)

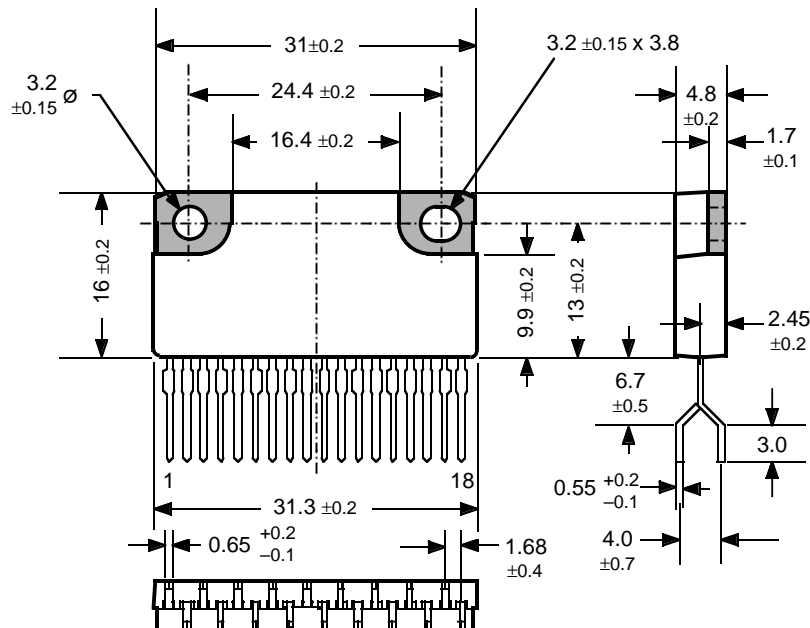

Dwa. MK-002-18 mm

- NOTES: 1. Exact body and lead configuration at vendor's option within limits shown.
2. Recommended mounting hardware torque: 4.34 – 5.79 lbf•ft (6 – 8 kgf•cm or 0.588 – 0.784 Nm).
3. The hatched area is exposed (electrically isolated) heat spreader.
4. Recommend use of metal-oxide-filled, alkyl-degenerated oil base, silicone grease (Dow Corning 340 or equivalent).

**SLA7024M, SLA7026M, AND SMA7029M
HIGH-CURRENT PWM,
UNIPOLAR STEPPER MOTOR
CONTROLLER/DRIVERS**

SMA7029M
Dimensions in Inches
(for reference only)

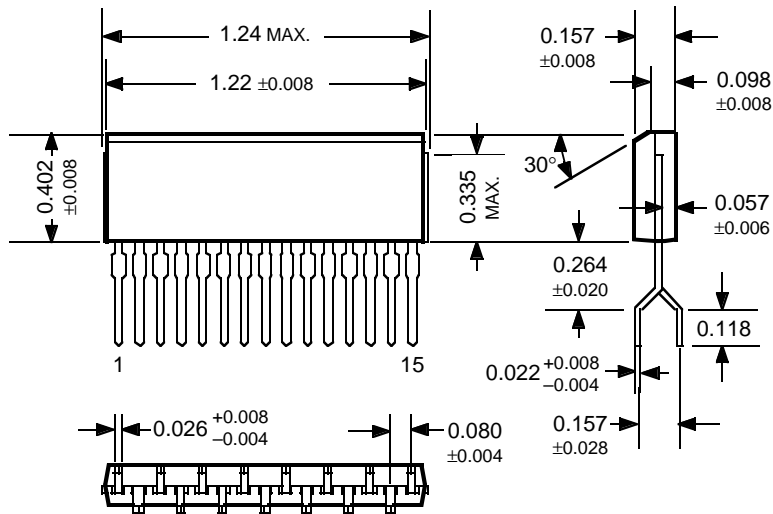

Dimensions in Millimeters
(controlling dimensions)

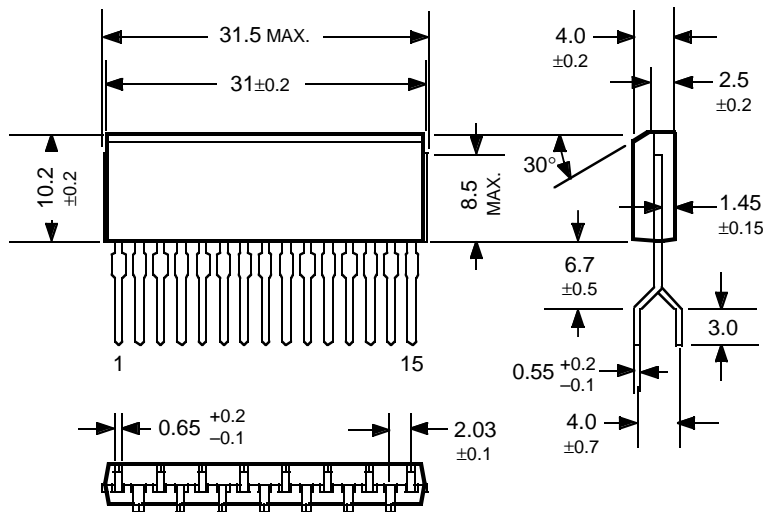

Dwg. MK-005-15 mm

NOTE: Exact body and lead configuration at vendor's option within limits shown.

The products described here are manufactured in Japan by Sanken Electric Co., Ltd. for sale by Allegro MicroSystems, Inc.

Sanken Electric Co., Ltd. and Allegro MicroSystems, Inc. reserve the right to make, from time to time, such departures from the detail specifications as may be required to permit improvements in the design of their products.

The information included herein is believed to be accurate and reliable. However, Sanken Electric Co., Ltd. and Allegro MicroSystems, Inc. assume no responsibility for its use; nor for any infringements of patents or other rights of third parties which may result from its use.



115 Northeast Cutoff, Box 15036
Worcester, Massachusetts 01615-0036 (508) 853-5000

