

Three Phase Rectifier Bridge with Fast Diodes and "Softstart" Thyristor

$I_{dAVM} = 39 \text{ A}$
 $I_{TAVM} = 31 \text{ A}$
 $V_{RRM} = 1200-1600 \text{ V}$

V_{RSM}	V_{RRM}	Type
V_{DSM}	V_{DRM}	
V	V	
1300	1200	VUC 36-12go2
1500	1400	VUC 36-14go2
1700	1600	VUC 36-16go2

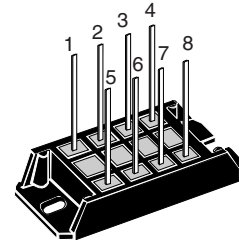
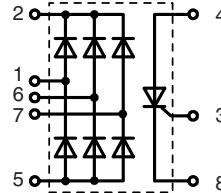

Symbol	Conditions	Maximum Ratings			
		Diode	Thyristor		
I_{dAV}	$T_K = 85^\circ\text{C}$; module	34	-	A	
I_{dAVM}	module	39	-	A	
I_{TAVM}	$T_K = 85^\circ\text{C}$; (DC)	-	31	A	
$I_{FSM}^{\dagger} I_{TSM}$	$T_{VJ} = 45^\circ\text{C}$;	$t = 10 \text{ ms}$ (50 Hz), sine	300	400	A
	$V_R = 0$	$t = 8.3 \text{ ms}$ (60 Hz), sine	330	440	A
I^2t	$T_{VJ} = T_{VJM}$	$t = 10 \text{ ms}$ (50 Hz), sine	270	360	A
	$V_R = 0$	$t = 8.3 \text{ ms}$ (60 Hz), sine	300	400	A
$(di/dt)_{cr}$	$T_{VJ} = 45^\circ\text{C}$	$t = 10 \text{ ms}$ (50 Hz), sine	450	800	A^2s
	$V_R = 0$	$t = 8.3 \text{ ms}$ (60 Hz), sine	460	810	A^2s
$(di/dt)_{cr}$	$T_{VJ} = T_{VJM}$	$t = 10 \text{ ms}$ (50 Hz), sine	365	650	A^2s
	$V_R = 0$	$t = 8.3 \text{ ms}$ (60 Hz), sine	380	670	A^2s
$(dv/dt)_{cr}$	$T_{VJ} = T_{VJM}$	repetitive, $I_T = 50 \text{ A}$		150	$\text{A}/\mu\text{s}$
	$V_{DR} = 2/3 V_{DRM}$	non repetitive, $I_T = I_{TAVM}$		500	$\text{A}/\mu\text{s}$
V_{RGM}	$f = 400 \text{ Hz}$, $t_p = 200 \mu\text{s}$				
	$I_G = 0.3 \text{ A}$, $di_G/dt = 0.3 \text{ A}/\mu\text{s}$				
P_{GM}	$T_{VJ} = T_{VJM}$	$t_p = 30 \mu\text{s}$	\leq	10	W
	$I_T = I_{TAVM}$	$t_p = 10 \text{ ms}$	\leq	1	W
P_{GAVM}				0.5	W
T_{VJ}			-40...+125		$^\circ\text{C}$
T_{VJM}			125		$^\circ\text{C}$
T_{stg}			-40...+125		$^\circ\text{C}$
V_{ISOL}	50/60 Hz, RMS	$t = 1 \text{ min}$		3000	V~
	$I_{ISOL} \leq 1 \text{ mA}$	$t = 1 \text{ s}$		3600	V~
M_d	Mounting torque (M5) (10-32 UNF)			2-2.5	Nm
				18-22	lb.in.
Weight	typ.			28	g

Features

- Package with DCB ceramic base plate
- Isolation voltage 3600 V~
- Planar passivated chips
- Fast recovery diodes to reduce EMI
- Separate thyristor for softstart
- Solderable terminals
- UL registered E 72873

Applications

- Input rectifier for switching power supplies (SMPS)
- Softstart capacitor charging
- Electric drives and auxiliaries

Advantages

- Easy to mount with two screws
- Space and weight savings
- Improved temperature & power cycling
- Up to 10 dB lower EMI/RFI compared to standard rectifier

Dimensions in mm (1 mm = 0.0394")

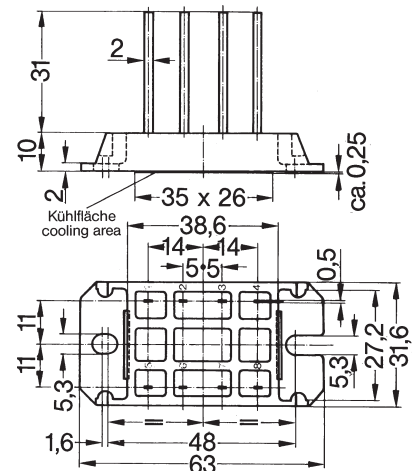

Data according to IEC 60747 and refer to a single thyristor/diode unless otherwise stated.

IXYS reserves the right to change limits, test conditions and dimensions.

20091201a

Symbol	Conditions	Characteristic Values	
		Diode	Thyristor
I_R, I_D	$V_R = V_{RRM}; V_D = V_{DRM}$ $T_{VJ} = T_{VJM}$ $T_{VJ} = 25^\circ\text{C}$	≤ 5 ≤ 0.3	≤ 5 mA ≤ 0.3 mA
V_F, V_T	$I_F = 55$ A; $I_T = 45$ A, $T_{VJ} = 25^\circ\text{C}$	≤ 1.85	≤ 1.4 V
V_{T0} r_T	For power-loss calculations only ($T_{VJ} = 125^\circ\text{C}$)	1.2 16	0.85 V 10 m Ω
V_{GT} I_{GT}	$V_D = 6$ V; $V_D = 6$ V; $T_{VJ} = 25^\circ\text{C}$ $T_{VJ} = 25^\circ\text{C}$		≤ 1.5 V ≤ 80 mA
V_{GD} I_{GD}	$T_{VJ} = T_{VJM};$ $T_{VJ} = T_{VJM};$ $V_D = 2/3 V_{DRM}$ $V_D = 2/3 V_{DRM}$		≤ 0.2 V ≤ 5 mA
I_L	$T_{VJ} = 25^\circ\text{C}; t_G = 30$ μs $I_G = 0.3$ A; $di_G/dt = 0.3$ A/ μs		≤ 300 mA
I_H	$T_{VJ} = 25^\circ\text{C}; V_D = 6$ V; $R_{GK} = \infty$		≤ 100 mA
t_{gd}	$T_{VJ} = 25^\circ\text{C}; V_D = 1/2 V_{DRM}$ $I_G = 0.3$ A; $di_G/dt = 0.3$ A/ μs		≤ 2.5 μs
t_q	$T_{VJ} = 125^\circ\text{C}; I_T = 15$ A, $t_p = 300$ μs , $-di/dt = 10$ A/ μs $V_R = 100$ V, $dv/dt = 20$ V/ μs , $V_D = 2/3 V_{DRM}$		typ. 130 μs
t_{rr}	$T_{VJ} = 25^\circ\text{C}; I_F = 10$ A; $-di/dt = 10$ A/ μs , $V_R = 1/2 V_{RRM}$	≤ 1.5	- μs
R_{thJC}	per thyristor (diode); DC current per module	1.4 0.233	0.9 K/W - K/W
R_{thJH}	per thyristor (diode); DC current per module	2.0 0.333	1.1 K/W - K/W
d_S	Creeping distance on surface		7 mm
d_A	Creepage distance in air		7 mm
a	Max. allowable acceleration		50 m/s ²