

POWER MANAGEMENT

Description

The SC1410A is designed to provide a simple, fast charging solution for rechargeable batteries that require constant-current and/or constant voltage charging, including nickel-cadmium (NiCd), nickel-metal-hydride (NiMH) and lithium-ion (Li-Ion). With a voltage reference accuracy of 0.5% the SC1410A satisfies the tight constant-voltage charging requirements of lithium cells.

The SC1410A simplifies battery charger design by integrating a high efficiency PWM with an internal 1.5A switch and 0.1ohm current sense resistor, while the 500kHz switching frequency allows a very small inductor to be used. Only one external resistor is required to program the full 1.5A charging current to within 5% accuracy.

Charging circuits for batteries ranging from 2V to 18V are easily implemented using the SC1410A. No ground sensing of current is required, allowing the battery's negative terminal to be connected directly to ground. No blocking diode is required between the IC and the battery since the SC1410A enters sleep mode and consumes only 3µA when the AC adapter is unplugged. Other features include soft start, overvoltage protection, and a shutdown pin. The SC1410A is available in a 16 pin QSOP package.

Features

- ◆ Charges NiCd, NiMH and Lithium-Ion batteries
- ◆ High efficiency current mode with 1.5A internal switch and sense resistor
- ◆ 3% Typical charging current accuracy
- ◆ Precision 0.5% voltage reference for voltage mode charging or over voltage protection
- ◆ Current sensing can be either terminal of battery
- ◆ Low reverse battery drain current: 3µA
- ◆ Charging current soft start
- ◆ Shutdown control
- ◆ 500kHz switching uses small inductor

Applications

- ◆ Chargers for NiCd*, NiMH* and Lithium batteries
- ◆ Step down switching regulator with precision adjustable current limit

*NiCd and NiMh batteries require external charge termination circuitry not contained in the SC1410A

Typical Application Circuits

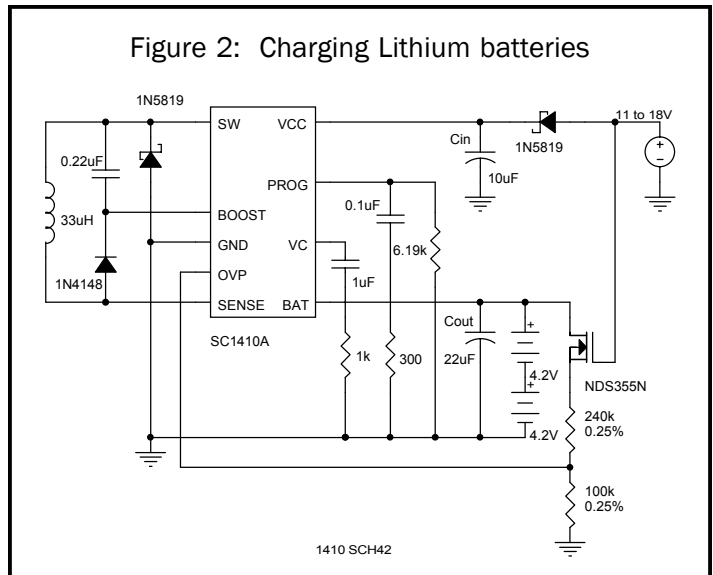
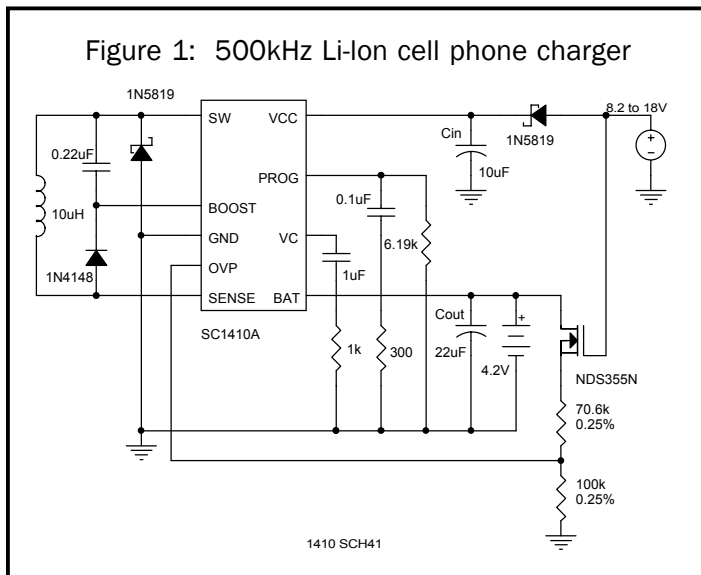

POWER MANAGEMENT
Absolute Maximum Ratings

Exceeding the specifications below may result in permanent damage to the device, or device malfunction. Operation outside of the parameters specified in the Electrical Characteristics section is not implied.

Parameter	Symbol	Maximum	Units
Supply Voltage	$V_{VCC(MAX)}$	20	V
Switch Voltage with respect to GND		-3	V
Boost Pin Voltage with respect to GND		+24/-5	V
VC, PROG, OVP Pin Voltage		8	V
I_{BAT} (Average)		1.5	A
Thermal Resistance, Junction to Case	θ_{JC}	30	°C/W
Thermal Resistance, Junction to Ambient	θ_{JA}	75	°C/W
Operating Temperature Range	T_A	0 to 70	°C
Storage Temperature Range	T_{STG}	-65 to +150	°C
Lead Temperature (Soldering) 10 Sec.	T_{LEAD}	300	°C

Electrical Characteristics

Unless specified: $V_{VCC} = 16V$, $V_{BAT} = 8V$, $I_{BAT} = 0$

Parameter	Conditions	Min	Typ	Max	Units
Supply Current	$V_{PROG} = 2.7V$, $V_{VCC} \leq 20V$		4.5	6.5	mA
DC Battery Current, I_{BAT}	$8V < V_{VCC} < 18V$, $0V < V_{BAT} \leq 16V$ $R_{PROG} = 4.93k$ $R_{PROG} = 3.28k$ $R_{PROG} = 49.3k$	0.93 1.35 75	1.0 1.5 100	1.07 1.65 125	A A mA
Minimum Input Operating Voltage	Undervoltage lockout	6.2	7	7.8	V
Reverse Current from Battery	$V_{BAT} \leq 12V$, $0^\circ C \leq T_J \leq 70^\circ C$		3	20	μA
Boost Pin Current	$V_{VCC} - V_{BOOST} \leq 18V$ $2V \leq V_{BOOST} - V_{VCC} \leq 16V$ (Switch ON)		0.25 6	30 14	μA mA
Switch					
Switch ON Resistance	$V_{VCC} = 10V$ $I_{SW} = 1.5A$, $V_{BOOST} - V_{SW} \geq 2V$ $I_{SW} = 1A$, $V_{BOOST} - V_{SW} < 2V$		0.5	0.65 2.0	Ω
$\Delta I_{BOOST} / \Delta I_{SW}$ During Switch ON	$V_{BOOST} = 24V$, $I_{SW} \leq 1A$		20	35	mA/A
Switch OFF Leakage Current	$V_{SW} = 0V$, $V_{VCC} \leq 18V$		4	200	μA
Maximum V_{BAT} with Switch ON				$V_{VCC} - 2$	V
Minimum I_{PROG} for Switch ON			4	20	μA
Minimum I_{PROG} for Switch OFF	$V_{PROG} \leq 1V$	0.5	2.4		mA

POWER MANAGEMENT
Electrical Characteristics (Cont.)

 Unless specified: $V_{VCC} = 16V$, $V_{BAT} = 8V$, $I_{BAT} = 0$

Parameter	Conditions	Min	Typ	Max	Units
Current Sense Amplifier Inputs (SENSE, BAT)					
Sense Resistance (RS1)			0.08	0.12	Ω
Total Resistance from SENSE to BAT			0.2	0.25	Ω
BAT Bias Current	$V_{VC} < 0.3V$ $V_{VC} > 0.6V$		-200 700	-375 1300	μA
Input Common Mode Limit (Low)		-0.25			V
Input Common Mode Limit (High)				$\frac{V_{VCC}}{2}$	V
Reference					
Reference Voltage	$R_{PROG} = 3.28k$, Measured at OVP with VA supplying I_{PROG} and Switch OFF	2.448	2.465	2.482	V
Reference Voltage Tolerance	$8V \leq V_{VCC} \leq 18V$, $0^\circ C \leq T_J \leq 70^\circ C$ $8V \leq V_{VCC} \leq 18V$, $0^\circ C \leq T_J \leq 125^\circ C$	2.446 2.441	2.465	2.480 2.489	V
Oscillator					
Switching Frequency		440	500	550	kHz
Maximum Duty Cycle		77			%
Current Amplifier (CA2)					
Transconductance	$V_{VC} = 1V$, $I_{VC} = \pm 1\mu A$	150	250	550	μmho
Maximum V_{VC} for Switch OFF				0.6	V
I_{VC} Current (Out of Pin)	$V_{VC} \geq 0.6V$			100	μA
Voltage Amplifier (VA)					
Transconductance	Output current from 100 μA to 500 μA	0.5	1.2	2.5	mho
Output Source Current, $V_{VCC} = 10V$	$V_{PROG} = V_{OVP} = V_{REF} + 30mV$	1.3			mA
OVP Input Bias Current	At 0.75mA VA Output Current		50	150	nA

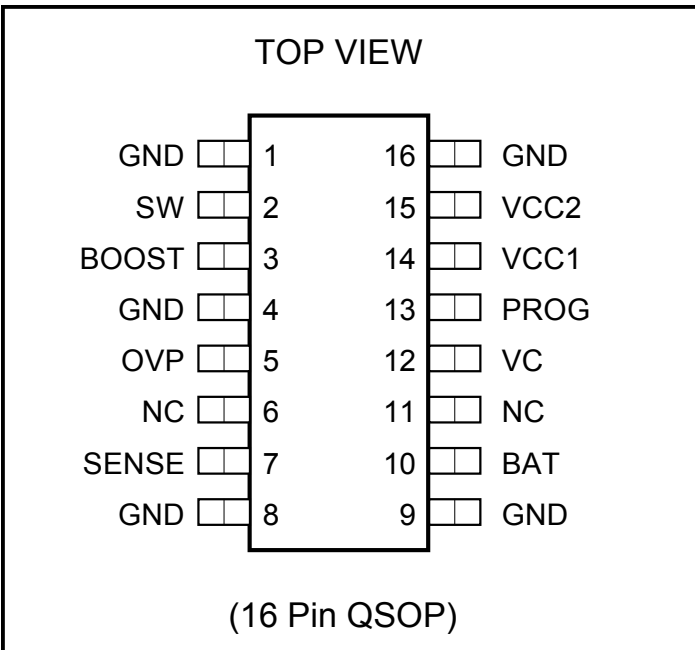
POWER MANAGEMENT
Pin Configuration

Ordering Information

Device	Package ⁽¹⁾
SC1410ACQS.TR	QSOP-16

Note:

(1) Only available in tape and reel packaging. A reel contains 2500 devices.

Pin Descriptions

Pin Number	Pin Name	Pin Function
1,8,9,16	GND	These Ground Pins are fused to the die attach paddle for optimum thermal performance connect these pins to large PCB copper area.
2	SW	Switch output.
3	BOOST	This pin is used to bootstrap and drive the switch power NPN transistor to a low on-voltage for low power dissipation.
4	GND	Ground pin.
5	OVP	Feedback node for constant voltage output, ground if not required.
6,11	NC	No connection, do not connect to these pins.
7	SENSE	Current amplifier CA1 input. Sensing can be at either terminal of the battery.
10	BAT	Current amplifier CA1 input.
12	VC	Control signal of the inter loop of the current mode PWM. Switching starts at 0.7V and higher VC corresponds to higher charging current in normal operation. A capacitor of at least 1uf to GND filters out noise and controls the rate of soft start. To shut down switching, pull this pin low. Typical output current is 30uA.
13	PROG	This pin is for programming the charging current and for system loop compensation.
14	VCC1	Supply for the chip.
15	VCC2	Supply for the chip.

POWER MANAGEMENT

Block Diagram

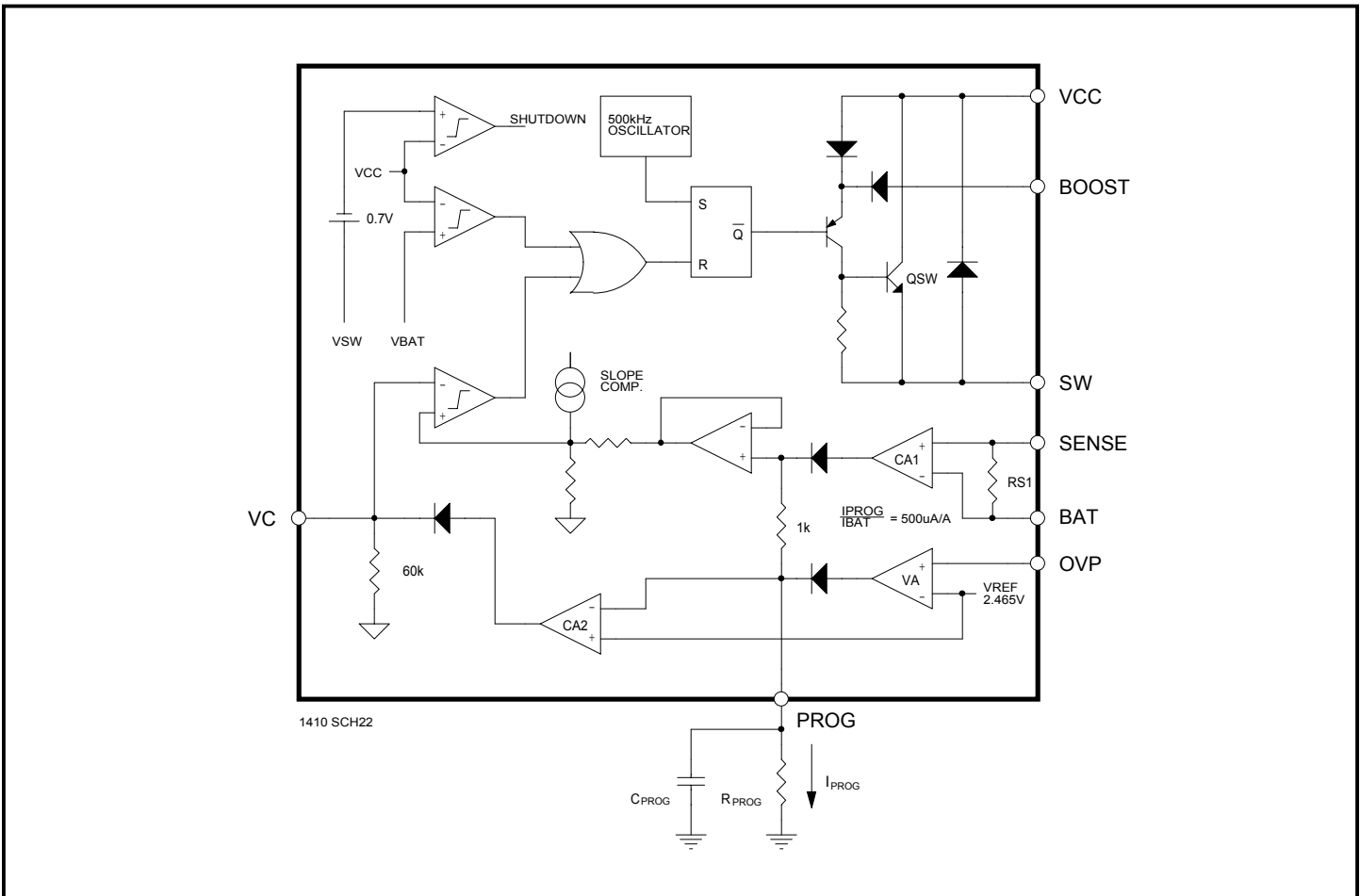

Theory of Operation

The SC1410A is a current mode, buck converter which operates in constant current (CC) and constant voltage (CV) modes. There are two feedback mechanisms, a fraction of the output voltage is sensed at OVP and the output current is sensed by RS1. When either or both of these feedback mechanisms are implemented, the loops act to maintain a nearly constant voltage of VREF at the PROG pin.

In CC mode, the current amplifier CA1 and the sense resistor RS1 combine to generate a program current (I_{PROG}) to output current ratio of $500\mu A/A$. The programmed output current is therefore given by :-

$$I_{BAT} = 2000 \cdot I_{PROG} = \frac{2 \cdot 2.465}{R_{PROG}}$$

or

$$R_{PROG} = \frac{4.93}{I_{BAT}}$$

where

I_{BAT} is in Amps, R_{PROG} in k Ω

As the voltage at the OVP pin rises, reaching V_{REF} , the voltage amplifier VA sources current into R_{PROG} , reducing I_{BAT} . I_{BAT} will go from full programmed current to zero with only a few mV increase at the OVP pin.

The SR latch is set by the 500kHz oscillator, turning on the output transistor (QSW). The outer control loop of CA2, the 60k resistor and external components on the VC pin sets a DC level against which the inner loop DC and AC current information generated by RS1, CA1 and the buffer and divider is compared. When the voltage at the + pin of the comparator exceeds the DC level at the - pin, the latch is reset and QSW turned off.

POWER MANAGEMENT
Component Selection

Inductor - A suitable value of inductor for most applications is 10uH, this value is a compromise between ripple current and size. A 10uH inductor will result in less than 1A pk. pk. ripple at maximum input voltage and 50% duty cycle, which is the worst case. Higher inductance values will result in lower ripple but for similar current ratings, will be physically larger and more costly. The inductor should be sized so that it will not saturate at peak current. Peak inductor current is:-

$$I_{PK} = I_o + \frac{V_o}{V_{IN} \cdot L \cdot f} \cdot \frac{(V_{IN} - V_o)}{2}$$

Input and Output capacitors - There are no special requirements for input and output capacitors beyond the capability to handle the ripple current. For the input capacitor(s) the RMS ripple current rating required is approximately 50% of I_{BAT} and for the output capacitor(s) the worst case RMS ripple rating required can be determine from:-

$$I_{RMS} = \frac{V_o}{V_{IN} \cdot L \cdot f} \cdot \frac{(V_{IN} - V_o)}{2 \cdot \sqrt{3}}$$

Note that this ripple rating is not a function of I_{BAT} . Worst case ripple current rating requirement occurs at $V_o = V_{IN}/2$. Good choices for input and output capacitors are high value ceramics, special polymer capacitors such as those from Panasonic or, if space permits, low ESR aluminum electrolytics. Tantalum capacitors are not recommended, particularly for input capacitors unless they are specially tested for surge current and heavily derated for voltage.

R_{PROG} - The current programming resistor determines the charging current according to the following equations:-

$$I_{BAT} = 2000 \cdot I_{PROG} = \frac{2 \cdot 2.465}{R_{PROG}}$$

or

$$R_{PROG} = \frac{4.93}{I_{BAT}}$$

where

I_{BAT} is in Amps, R_{PROG} in k Ω

Soft Start - A capacitor on the VC Pin implements the soft start function for the SC1410A. Soft start controls the rate at which output voltage rises so that high current surges can be avoided or minimized. In order for soft start to be effective, the soft start time must be much longer than the ramp up time of the input supply. The ratio of the soft start cap to the PROG pin cap must also be chosen to ensure that the PROG pin does not lag the soft start. Recommended values for the soft start capacitor and the PROG pin capacitor are 1uF and 0.1uF respectively. The input supply must also be specified with some care. It is possible for a current limited or power limited input supply to “latch-up” and operate at a lower output voltage than it is designed for, be sure that the supply can provide adequate power at the UVLO point. For example, charging a battery at 800mA with a 3.6V terminal voltage (typical for a partially discharged single cell Li-Ion) requires $3.6 \cdot 0.8 = 2.88W$, allowing for efficiency one might choose a 3.6W Input supply or 300mA at 12V. However if the 300mA is a hard current limit, as the supply ramps up through the SC1410A UVLO at 7V, the available output power is only $7 \cdot 0.3$ or 2.1W. If soft start is too fast or the input supply ramp up is too slow, the input supply will become “stuck” at this low level and will oscillate around the 1410A UVLO point. To prevent this from happening, choose a higher power input supply or ensure soft start timings are adequate or use an external UVLO, holding down the VC pin until the input supply has ramped to a voltage where it can sustain the required output power.

POWER MANAGEMENT

Typical Characteristics

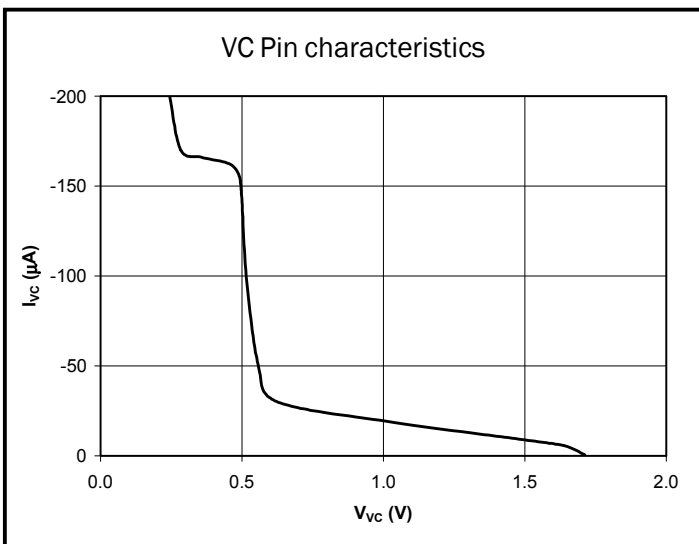
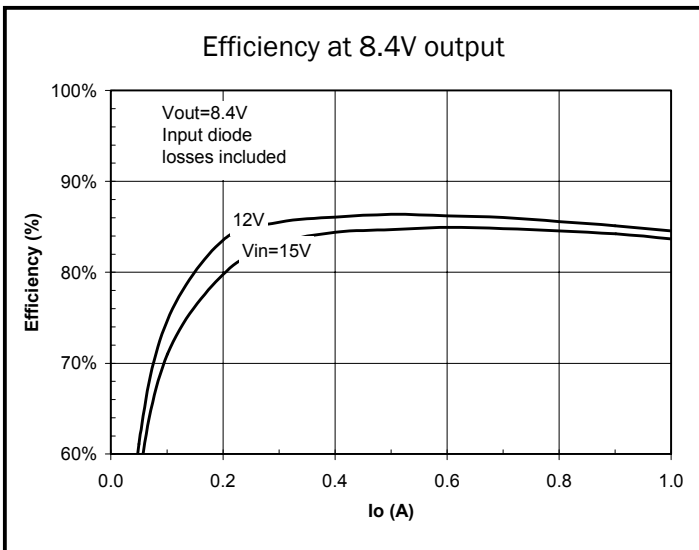
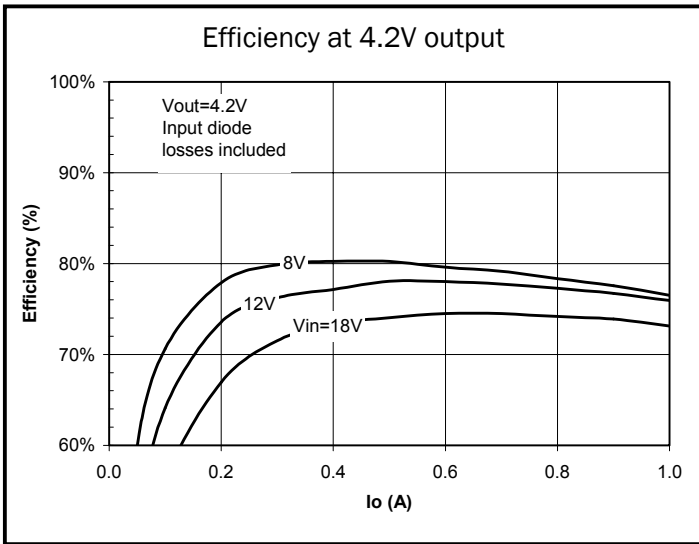

POWER MANAGEMENT

Outline Drawing - QSOP-16

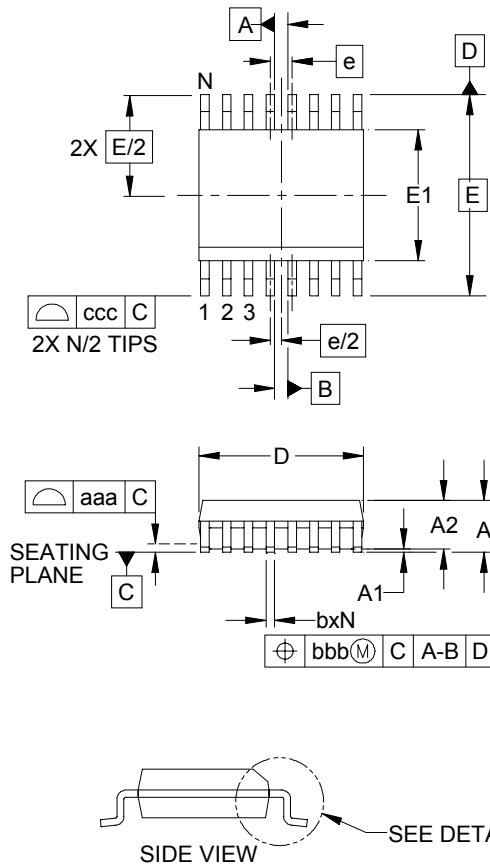

DIM	INCHES			MILLIMETERS		
	MIN	NOM	MAX	MIN	NOM	MAX
A	.053	-	.069	1.35	-	1.75
A1	.004	-	.010	0.10	-	0.25
A2	.049	-	.065	1.25	-	1.65
b	.008	-	.012	0.20	-	0.31
c	.006	-	.010	0.15	-	0.25
D	.189	.193	.197	4.80	4.90	5.00
E1	.150	.154	.158	3.80	3.90	4.00
E	.236 BSC			6.00 BSC		
e	.025 BSC			0.635 BSC		
h	.010	-	.020	0.25	-	0.50
L	.016	.033	.041	0.40	0.84	1.04
L1	(0.041)			(1.04)		
N	16			16		
theta1	0°	-	8°	0°	-	8°
aaa	.004			0.10		
bbb	.007			0.18		
ccc	.008			0.20		

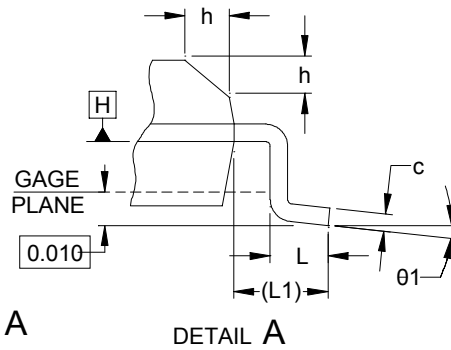

NOTES:

1. CONTROLLING DIMENSIONS ARE IN INCHES (ANGLES IN DEGREES).
2. DATUMS **-A-** AND **-B-** TO BE DETERMINED AT DATUM PLANE **-H-**
3. DIMENSIONS "E1" AND "D" DO NOT INCLUDE MOLD FLASH, PROTRUSIONS OR GATE BURRS.
4. REFERENCE JEDEC STD MO-137, VARIATION AB.

POWER MANAGEMENT

Land Pattern - QSOP-16

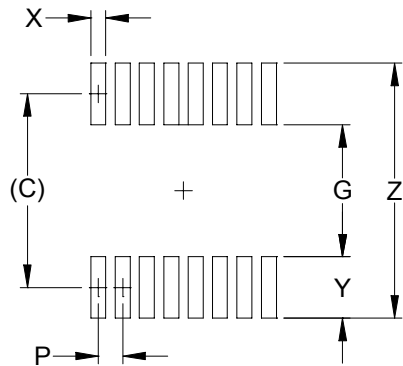

DIMENSIONS		
DIM	INCHES	MILLIMETERS
C	(.195)	(4.96)
G	.123	3.12
P	.025	0.635
X	.016	0.40
Y	.072	1.84
Z	.268	6.80

NOTES:

1. THIS LAND PATTERN IS FOR REFERENCE PURPOSES ONLY. CONSULT YOUR MANUFACTURING GROUP TO ENSURE YOUR COMPANY'S MANUFACTURING GUIDELINES ARE MET.

Contact Information

Semtech Corporation
 Power Management Products Division
 200 Flynn Road, Camarillo, CA 93012
 Phone: (805)498-2111 FAX (805)498-3804