

4K x 8/9 Dual-Port Static RAM with Sem, Int, Busy

Features

- True Dual-Ported Memory Cells that Enable Simultaneous Reads of the Same Memory Location
- 4K x 8 Organization (CY7C138)
- 4K x 9 Organization (CY7C139)
- 0.65-micron CMOS for Optimum Speed and Power
- High Speed Access: 15 ns
- Low Operating Power: $I_{CC} = 160 \text{ mA (max.)}$
- Fully Asynchronous Operation
- Automatic Power Down
- TTL Compatible
- Expandable Data Bus to 32/36 Bits or more using Master/Slave Chip Select when using more than one Device
- On-Chip Arbitration Logic
- Semaphores Included to Permit Software Handshaking between Ports
- $\overline{\text{INT}}$ Flag for Port-to-Port Communication
- Available in 68-pin PLCC
- Pb-free Packages Available

Functional Description

The CY7C138 and CY7C139 are high speed CMOS 4K x 8 and 4K x 9 dual-port static RAMs. Various arbitration schemes are included on the CY7C138/9 to handle situations when multiple processors access the same piece of data. Two ports are provided permitting independent, asynchronous access for reads and writes to any location in memory. The CY7C138/9 can be used as a standalone 8/9-bit dual-port static RAM or multiple devices can be combined to function as a 16/18-bit or wider master/slave dual-port static RAM. An M/S pin is provided for implementing 16/18-bit or wider memory applications without the need for separate master and slave devices or additional discrete logic. Application areas include interprocessor/multi-processor designs, communications status buffering, and dual-port video/graphics memory.

Each port has independent control pins: chip enable ($\overline{\text{CE}}$), read or write enable (R/W), and output enable ($\overline{\text{OE}}$). Two flags are provided on each port (BUSY and INT). BUSY signals that the port is trying to access the same location currently being accessed by the other port. The interrupt flag (INT) permits communication between ports or systems by means of a mail box. The semaphores are used to pass a flag, or token, from one port to the other to indicate that a shared resource is in use. The semaphore logic is comprised of eight shared latches. Only one side can control the latch (semaphore) at any time. Control of a semaphore indicates that a shared resource is in use. An automatic power down feature is controlled independently on each port by a chip enable ($\overline{\text{CE}}$) pin or SEM pin.

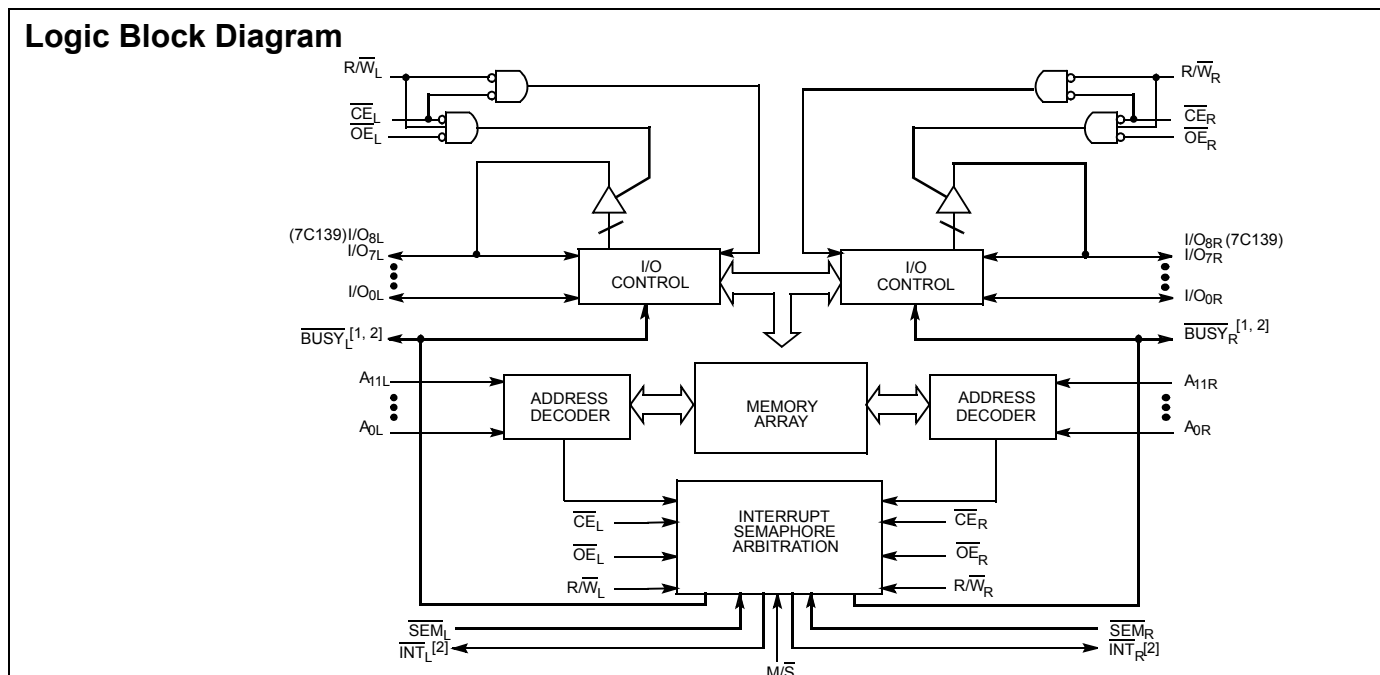

Notes

1. BUSY is an output in master mode and an input in slave mode.
2. Interrupt: push-pull output and requires no pull-up resistor.

Pin Configurations

Figure 1. 68-Pin PLCC (Top View)

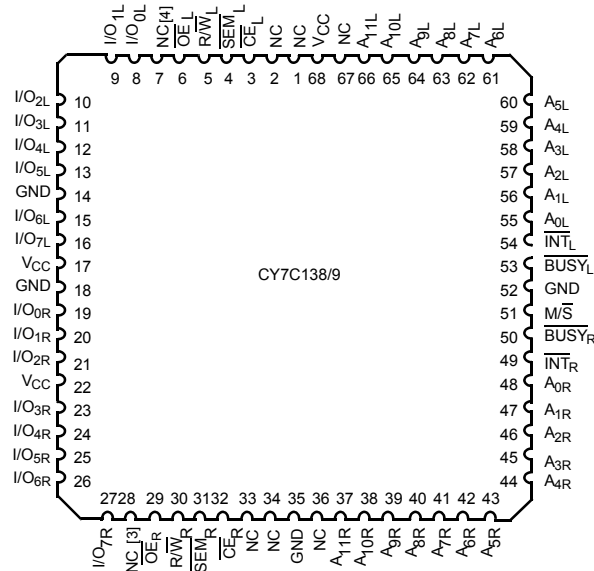

Table 1. Pin Definitions

Left Port	Right Port	Description
I/O _{0L} -7L(8L)	I/O _{0R} -7R(8R)	Data Bus Input/Output
A _{0L} -11L	A _{0R} -11R	Address Lines
CE _L	CE _R	Chip Enable
OE _L	OE _R	Output Enable
R/W _L	R/W _R	Read/Write Enable
SEM _L	SEM _R	Semaphore Enable. When asserted LOW, allows access to eight semaphores. The three least significant bits of the address lines will determine which semaphore to write or read. The I/O ₀ pin is used when writing to a semaphore. Semaphores are requested by writing a 0 into the respective location.
INT _L	INT _R	Interrupt Flag. INT _L is set when right port writes location FFE and is cleared when left port reads location FFE. INT _R is set when left port writes location FFF and is cleared when right port reads location FFF.
BUSY _L	BUSY _R	Busy Flag
M/S		Master or Slave Select
V _{CC}		Power
GND		Ground

Table 2. Selection Guide

Description		7C138-15 7C139-15	7C138-25 7C139-25	7C138-35 7C139-35	7C138-55 7C139-55	Unit
Maximum Access Time (ns)		15	25	35	55	ns
Maximum Operating Current	Commercial	220	180	160	160	mA
Maximum Standby Current for I _{SB1}	Commercial	60	40	30	30	mA

Notes

- I/O_{8R} on the CY7C139.
- I/O_{8L} on the CY7C139.

Maximum Ratings

Exceeding maximum ratings may impair the useful life of the device. These user guidelines are not tested.^[6]

- Storage Temperature -65°C to +150°C
- Ambient Temperature with Power Applied -55°C to +125°C
- Supply Voltage to Ground Potential.....-0.5V to +7.0V
- DC Voltage Applied to Outputs in High Z State-0.5V to +7.0V
- DC Input Voltage^[6]-0.5V to +7.0V
- Output Current into Outputs (LOW)..... 20 mA

Static Discharge Voltage..... >2001V (per MIL-STD-883, Method 3015)

Latch Up Current >200 mA

Operating Range

Range	Ambient Temperature	V _{CC}
Commercial	0°C to +70°C	5V ± 10%
Industrial	-40°C to +85°C	5V ± 10%

Electrical Characteristics Over the Operating Range

Parameter	Description	Test Conditions	7C138-15 7C139-15		7C138-25 7C139-25		Unit
			Min	Max	Min	Max	
V _{OH}	Output HIGH Voltage	V _{CC} = Min., I _{OH} = -4.0 mA	2.4		2.4		V
V _{OL}	Output LOW Voltage	V _{CC} = Min., I _{OL} = 4.0 mA		0.4		0.4	V
V _{IH}			2.2		2.2		V
V _{IL}	Input LOW Voltage			0.8		0.8	V
I _{IX}	Input Leakage Current	GND ≤ V _I ≤ V _{CC}	-10	+10	-10	+10	µA
I _{OZ}	Output Leakage Current	Output Disabled, GND ≤ V _O ≤ V _{CC}	-10	+10	-10	+10	µA
I _{CC}	Operating Current	V _{CC} = Max., I _{OUT} = 0 mA, Outputs Disabled	Commercial	220		180	mA
			Industrial			190	
I _{SB1}	Standby Current (Both Ports TTL Levels)	CE _L and CE _R ≥ V _{IH} , f = f _{MAX} ^[7]	Commercial	60		40	mA
			Industrial			50	
I _{SB2}	Standby Current (One Port TTL Level)	CE _L and CE _R ≥ V _{IH} , f = f _{MAX} ^[7]	Commercial	130		110	mA
			Industrial			120	
I _{SB3}	Standby Current (Both Ports CMOS Levels)	Both Ports CE and CE _R ≥ V _{CC} - 0.2V, V _{IN} ≥ V _{CC} - 0.2V or V _{IN} ≤ 0.2V, f = 0 ^[7]	Commercial	15		15	mA
			Industrial			30	
I _{SB4}	Standby Current (One Port CMOS Level)	One Port CE _L or CE _R ≥ V _{CC} - 0.2V, V _{IN} ≥ V _{CC} - 0.2V or V _{IN} ≤ 0.2V, Active Port Outputs, f = f _{MAX} ^[7]	Commercial	125		100	mA
			Industrial			115	

Notes

- 5. The Voltage on any input or I/O pin cannot exceed the power pin during power up.
- 6. Pulse width < 20 ns.
- 7. f_{MAX} = 1/t_{RC} = All inputs cycling at f = 1/t_{RC} (except output enable). f = 0 means no address or control lines change. This applies only to inputs at CMOS level standby I_{SB3}

Electrical Characteristics Over the Operating Range (continued)

Parameter	Description	Test Conditions	7C138-35 7C139-35		7C138-55 7C139-55		Unit
			Min	Max	Min	Max	
V _{OH}	Output HIGH Voltage	V _{CC} = Min., I _{OH} = -4.0 mA	2.4		2.4		V
V _{OL}	Output LOW Voltage	V _{CC} = Min., I _{OL} = 4.0 mA		0.4		0.4	V
V _{IH}			2.2		2.2		V
V _{IL}	Input LOW Voltage			0.8		0.8	V
I _{IX}	Input Leakage Current	GND ≤ V _I ≤ V _{CC}	-10	+10	-10	+10	μA
I _{OZ}	Output Leakage Current	Output Disabled, GND ≤ V _O ≤ V _{CC}	-10	+10	-10	+10	μA
I _{CC}	Operating Current	V _{CC} = Max., I _{OUT} = 0 mA, Outputs Disabled	Commercial	160		160	mA
			Industrial		180		
I _{SB1}	Standby Current (Both Ports TTL Levels)	CE _L and CE _R ≥ V _{IH} , f = f _{MAX} ^[7]	Commercial	30		30	mA
			Industrial		40		
I _{SB2}	Standby Current (One Port TTL Level)	CE _L and CE _R ≥ V _{IH} , f = f _{MAX} ^[7]	Commercial	100		100	mA
			Industrial		110		
I _{SB3}	Standby Current (Both Ports CMOS Levels)	Both Ports CE and CE _R ≥ V _{CC} - 0.2V, V _{IN} ≥ V _{CC} - 0.2V or V _{IN} ≤ 0.2V, f = 0 ^[7]	Commercial	15		15	mA
			Industrial		30		
I _{SB4}	Standby Current (One Port CMOS Level)	One Port CE _L or CE _R ≥ V _{CC} - 0.2V, V _{IN} ≥ V _{CC} - 0.2V or V _{IN} ≤ 0.2V, Active Port Outputs, f = f _{MAX} ^[7]	Commercial	90		90	mA
			Industrial		100		

Capacitance^[8]

Parameter	Description	Test Conditions	Max	Unit
C _{IN}	Input Capacitance	T _A = 25°C, f = 1 MHz, V _{CC} = 5.0V	10	pF
C _{OUT}	Output Capacitance		15	pF

Figure 2. AC Test Loads and Waveforms

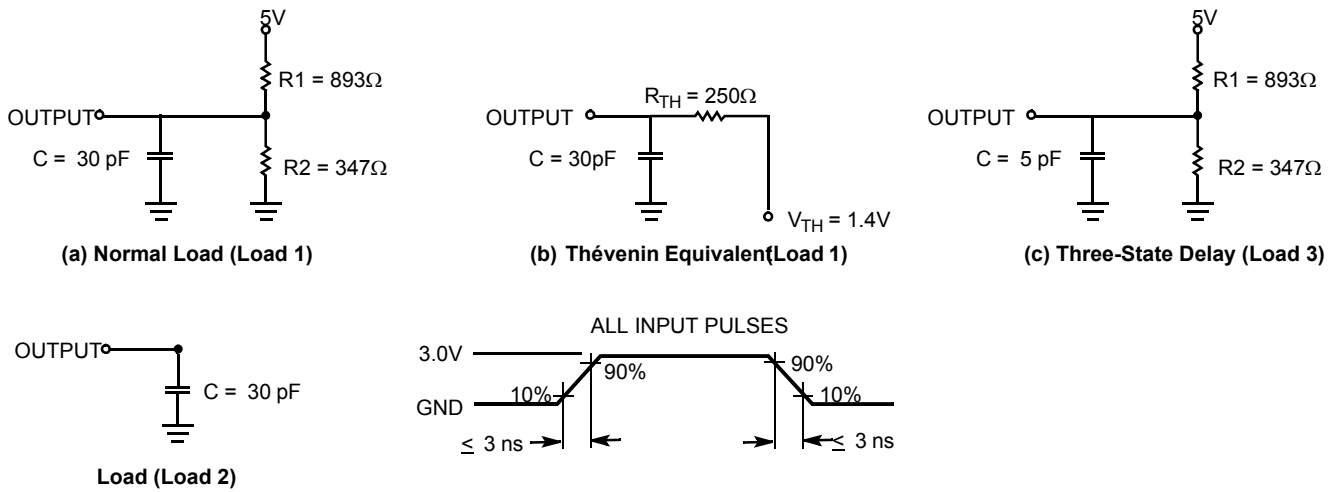

Switching Characteristics Over the Operating Range^[9]

Parameter	Description	7C138-15 7C139-15		7C138-25 7C139-25		7C138-35 7C139-35		7C138-55 7C139-55		Unit
		Min	Max	Min	Max	Min	Max	Min	Max	
READ CYCLE										
t _{RC}	Read Cycle Time	15		25		35		55		ns
t _{AA}	Address to Data Valid		15		25		35		55	ns
t _{OHA}	Output Hold From Address Change	3		3		3		3		ns
t _{ACE}	$\overline{\text{CE}}$ LOW to Data Valid		15		25		35		55	ns
t _{DOE}	$\overline{\text{OE}}$ LOW to Data Valid		10		15		20		25	ns
t _{LZOE} ^[10,11,12]	$\overline{\text{OE}}$ Low to Low Z	3		3		3		3		ns
t _{HZOE} ^[10,11,12]	$\overline{\text{OE}}$ HIGH to High Z		10		15		20		25	ns
t _{LZCE} ^[10,11,12]	$\overline{\text{CE}}$ LOW to Low Z	3		3		3		3		ns
t _{HZCE} ^[10,11,12]	$\overline{\text{CE}}$ HIGH to High Z		10		15		20		25	ns
t _{PU} ^[12]	$\overline{\text{CE}}$ LOW to Power Up	0		0		0		0		ns
t _{PD} ^[12]	$\overline{\text{CE}}$ HIGH to Power Down		15		25		35		55	ns
WRITE CYCLE										
t _{WC}	Write Cycle Time	15		25		35		55		ns
t _{SCE}	$\overline{\text{CE}}$ LOW to Write End	12		20		30		40		ns
t _{AW}	Address Setup to Write End	12		20		30		40		ns
t _{HA}	Address Hold From Write End	2		2		2		2		ns
t _{SA}	Address Setup to Write Start	0		0		0		0		ns
t _{PWE}	Write Pulse Width	12		20		25		30		ns
t _{SD}	Data Setup to Write End	10		15		15		20		ns
t _{HD}	Data Hold From Write End	0		0		0		0		ns

Note
8. Tested initially and after any design or process changes that may affect these parameters.

Switching Characteristics Over the Operating Range^[9] (continued)

Parameter	Description	7C138-15 7C139-15		7C138-25 7C139-25		7C138-35 7C139-35		7C138-55 7C139-55		Unit
		Min	Max	Min	Max	Min	Max	Min	Max	
$t_{HZWE}^{[11,12]}$	R \overline{W} LOW to High Z		10		15		20		25	ns
$t_{LZWE}^{[11,12]}$	R \overline{W} HIGH to Low Z	3		3		3		3		ns
$t_{WDD}^{[13]}$	Write Pulse to Data Delay		30		50		60		70	ns
$t_{DDD}^{[13]}$	Write Data Valid to Read Data Valid		25		30		35		40	ns
BUSY TIMING^[14]										
t_{BLA}	\overline{BUSY} LOW from Address Match		15		20		20		45	ns
t_{BHA}	\overline{BUSY} HIGH from Address Mismatch		15		20		20		40	ns
t_{BLC}	\overline{BUSY} LOW from \overline{CE} LOW		15		20		20		40	ns
t_{BHC}	\overline{BUSY} HIGH from \overline{CE} HIGH		15		20		20		35	ns
t_{PS}	Port Setup for Priority	5		5		5		5		ns
t_{WB}	R \overline{W} LOW after \overline{BUSY} LOW	0		0		0		0		ns
t_{WH}	R \overline{W} HIGH after \overline{BUSY} HIGH	13		20		30		40		ns
$t_{BDD}^{[15]}$	\overline{BUSY} HIGH to Data Valid		Note 15		Note 15		Note 15		Note 15	ns
INTERRUPT TIMING^[14]										
t_{INS}	\overline{INT} Set Time		15		25		25		30	ns
t_{INR}	\overline{INT} Reset Time		15		25		25		30	ns
SEMAPHORE TIMING										
t_{SOP}	SEM Flag Update Pulse (\overline{OE} or \overline{SEM})	10		10		15		20		ns
t_{SWRD}	SEM Flag Write to Read Time	5		5		5		5		ns
t_{SPS}	SEM Flag Contention Window	5		5		5		5		ns

Switching Waveforms

Figure 3. Read Cycle No. 1 (Either Port Address Access)^[16, 17]

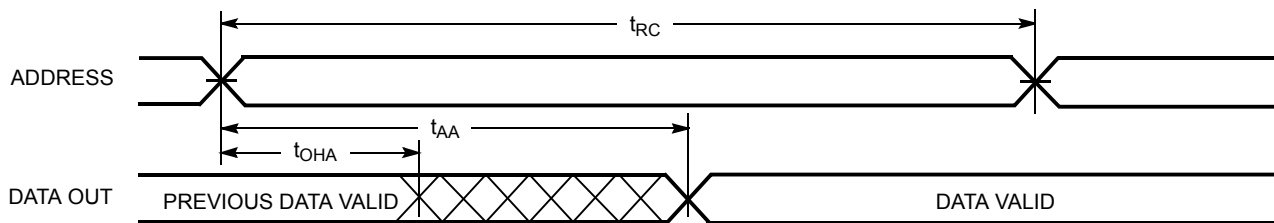

Notes

9. Test conditions assume signal transition time of 3 ns or less, timing reference levels of 1.5V, input pulse levels of 0 to 3.0V, and output loading of the specified I_{O1}/I_{O2} and 30-pF load capacitance.
10. At any temperature and voltage condition for any device, t_{HZCE} is less than t_{LZCE} and t_{HZOE} is less than t_{LZOE} .
11. Test conditions used are Load 3.
12. This parameter is guaranteed but not tested.
13. For information on part-to-part delay through RAM cells from writing port to reading port, refer to Read Timing with Port-to-Port Delay waveform.
14. Test conditions used are Load 2.
15. t_{BDD} is a calculated parameter and is the greater of $t_{WDD} - t_{PWE}$ (actual) or $t_{DDD} - t_{SD}$ (actual).

Switching Waveforms (continued)

Figure 4. Read Cycle No. 2 (Either Port $\overline{CE}/\overline{OE}$ Access)^[16, 18, 19]

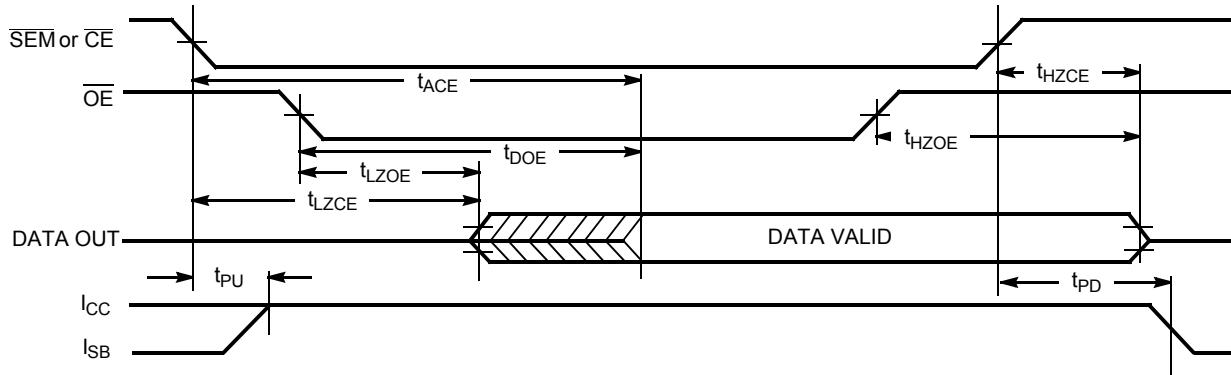
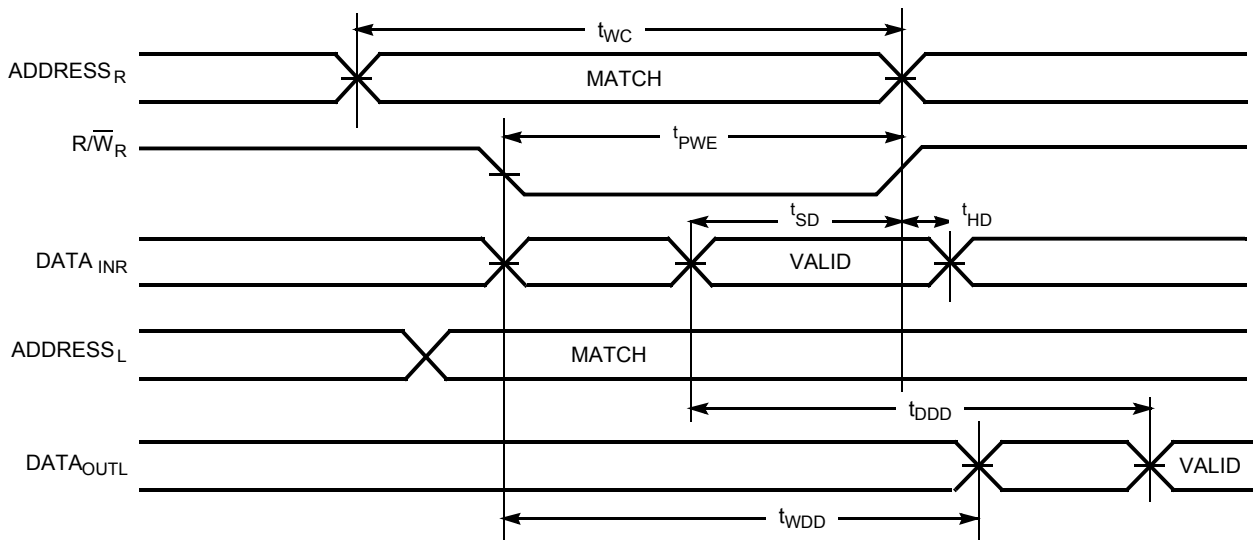

Figure 5. Read Timing with Port-to-Port Delay ($M/\overline{S} = L$)^[20, 21]



Notes

- 16. $\overline{R/\overline{W}}$ is HIGH for read cycle.
- 17. Device is continuously selected $\overline{CE} = \text{LOW}$ and $\overline{OE} = \text{LOW}$. This waveform cannot be used for semaphore reads.
- 18. Address valid prior to or coincident with \overline{CE} transition LOW.
- 19. $\overline{CE}_L = L$, $\overline{SEM} = H$ when accessing RAM. $\overline{CE} = H$, $\overline{SEM} = L$ when accessing semaphores.

Switching Waveforms (continued)

Figure 6. Write Cycle No. 1: $\overline{\text{OE}}$ Three-States Data I/Os (Either Port)^[22, 23, 24]

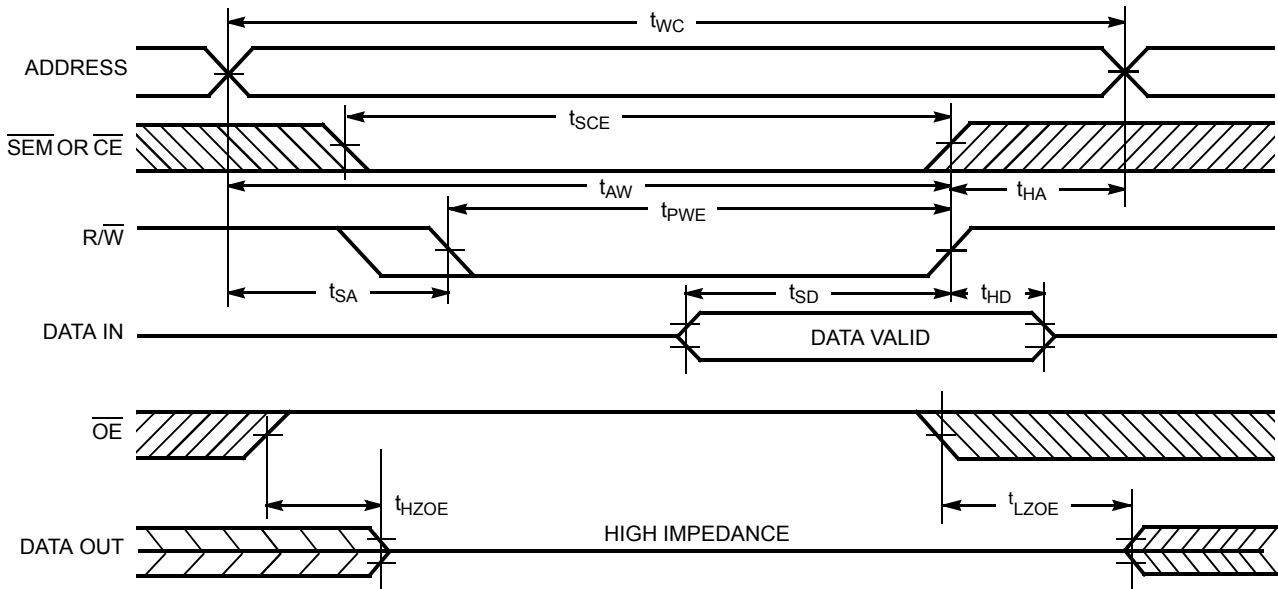
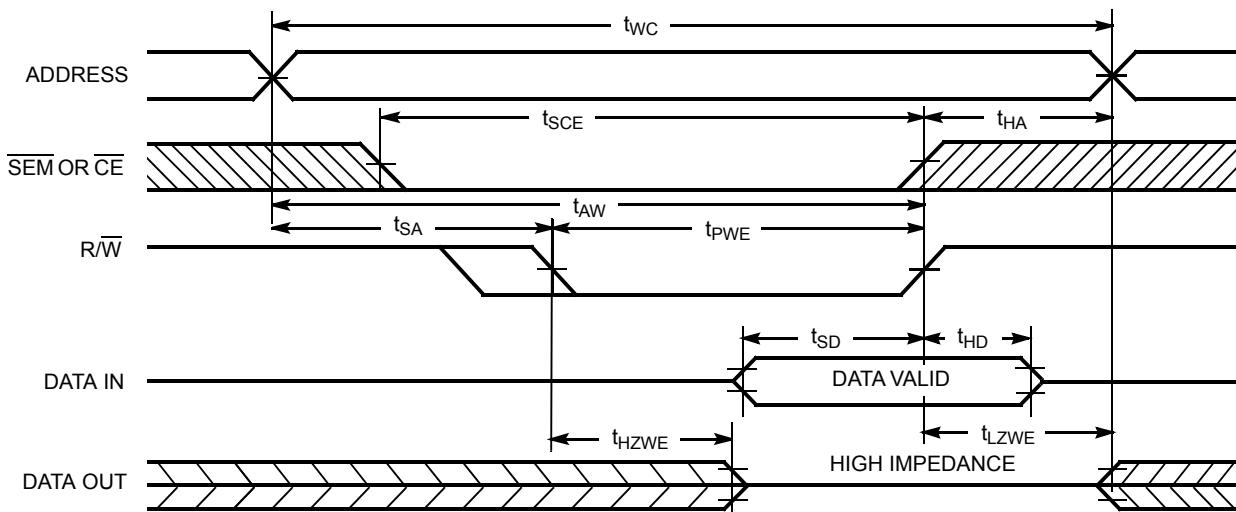

Figure 7. Write Cycle No. 2: $\overline{\text{R}/\overline{\text{W}}}$ Three-States Data I/Os (Either Port)^[22, 24, 25]



Notes

20. $\overline{\text{BUSY}} = \text{HIGH}$ for the writing port.
21. $\text{CE}_L = \text{CE}_R = \text{LOW}$.
22. The internal write time of the memory is defined by the overlap of $\overline{\text{CE}}$ or $\overline{\text{SEM}}$ LOW and $\overline{\text{R}/\overline{\text{W}}}$ LOW. Both signals must be LOW to initiate a write, and either signal can terminate a write by going HIGH. The data input setup and hold timing should be referenced to the rising edge of the signal that terminates the write.
23. If $\overline{\text{OE}}$ is LOW during a $\overline{\text{R}/\overline{\text{W}}}$ controlled write cycle, the write pulse width must be the larger of t_{PWE} or $(t_{\text{HZWE}} + t_{\text{SD}})$ to allow the I/O drivers to turn off and data to be placed on the bus for the required t_{SD} . If $\overline{\text{OE}}$ is HIGH during a $\overline{\text{R}/\overline{\text{W}}}$ controlled write cycle (as in this example), this requirement does not apply and the write pulse can be as short as the specified t_{PWE} .
24. $\overline{\text{R}/\overline{\text{W}}}$ must be HIGH during all address transitions.

Switching Waveforms (continued)

Figure 8. Semaphore Read After Write Timing, Either Side^[26]

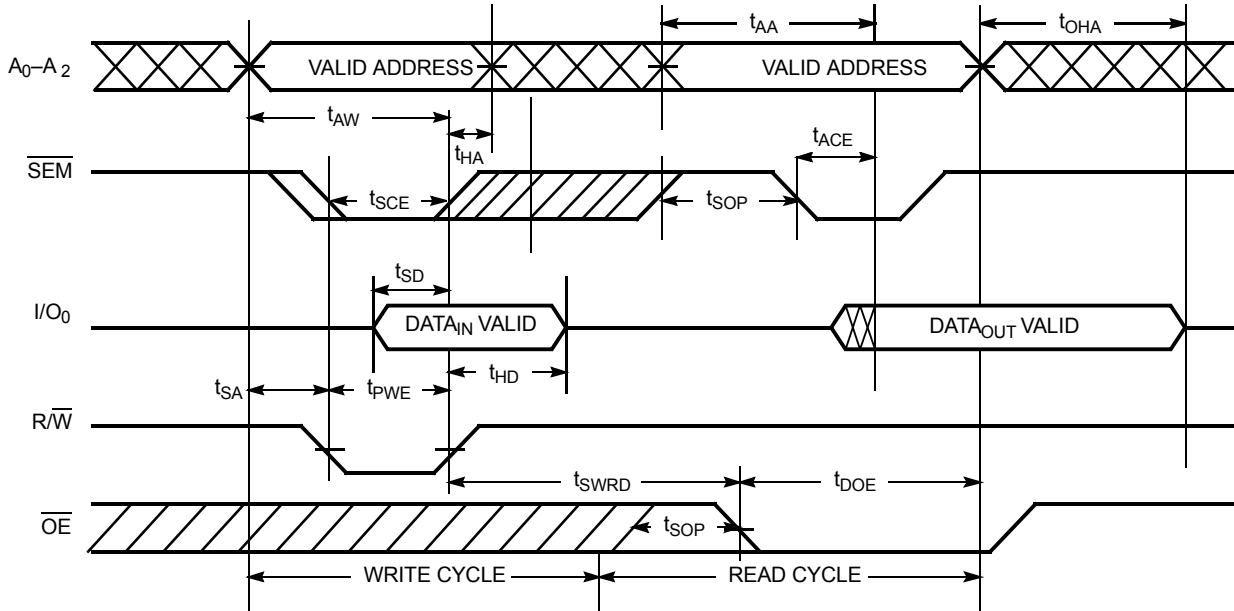
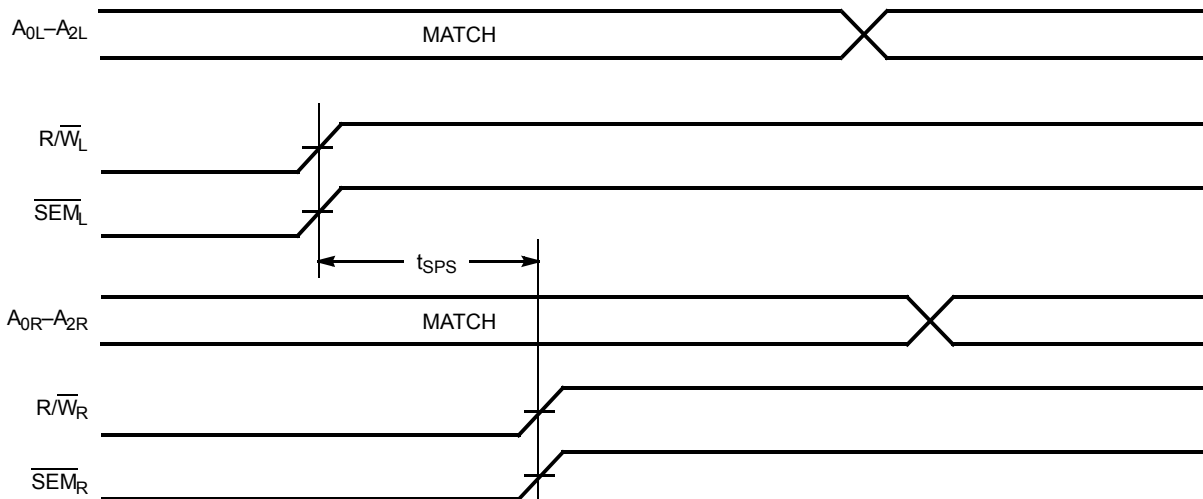

Figure 9. Timing Diagram of Semaphore Contention^[27, 28, 29]



Notes

- 25. Data I/O pins enter high impedance when \overline{OE} is held LOW during write.
- 26. \overline{CE} = HIGH for the duration of the above timing (both write and read cycle).

Switching Waveforms (continued)

Figure 10. Timing Diagram of Read with $\overline{\text{BUSY}} \text{ (M/S = HIGH)}$ ^[21]

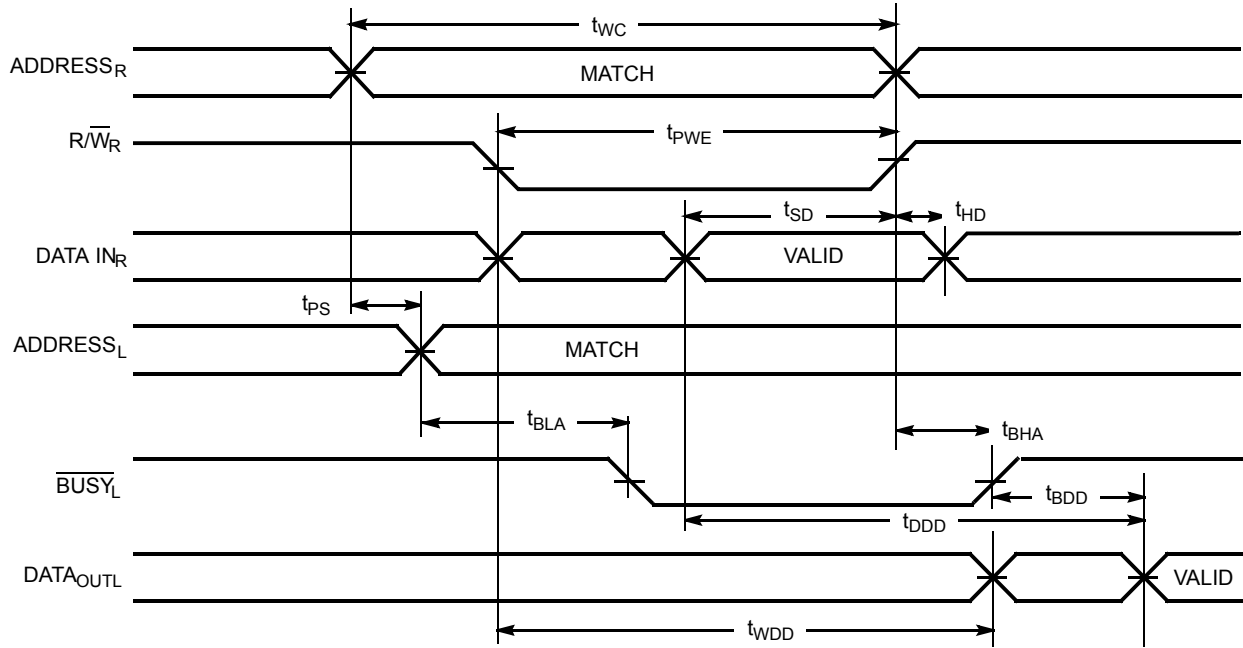
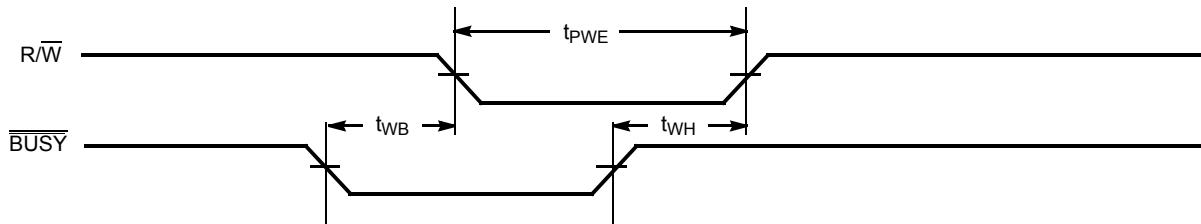

Figure 11. Write Timing with Busy Input ($\overline{\text{M/S}} = \text{LOW}$)



Notes

27. $\overline{\text{I/O}}_R = \overline{\text{I/O}}_L = \text{LOW}$ (request semaphore); $\overline{\text{CE}}_R = \overline{\text{CE}}_L = \text{HIGH}$

28. Semaphores are reset (available to both ports) at cycle start.

29. If t_{SPS} is violated, the semaphore will definitely be obtained by one side or the other, but there is no guarantee which side will control the semaphore.

Switching Waveforms (continued)

Figure 12. Busy Timing Diagram No. 1 ($\overline{\text{CE}}$ Arbitration)^[30]

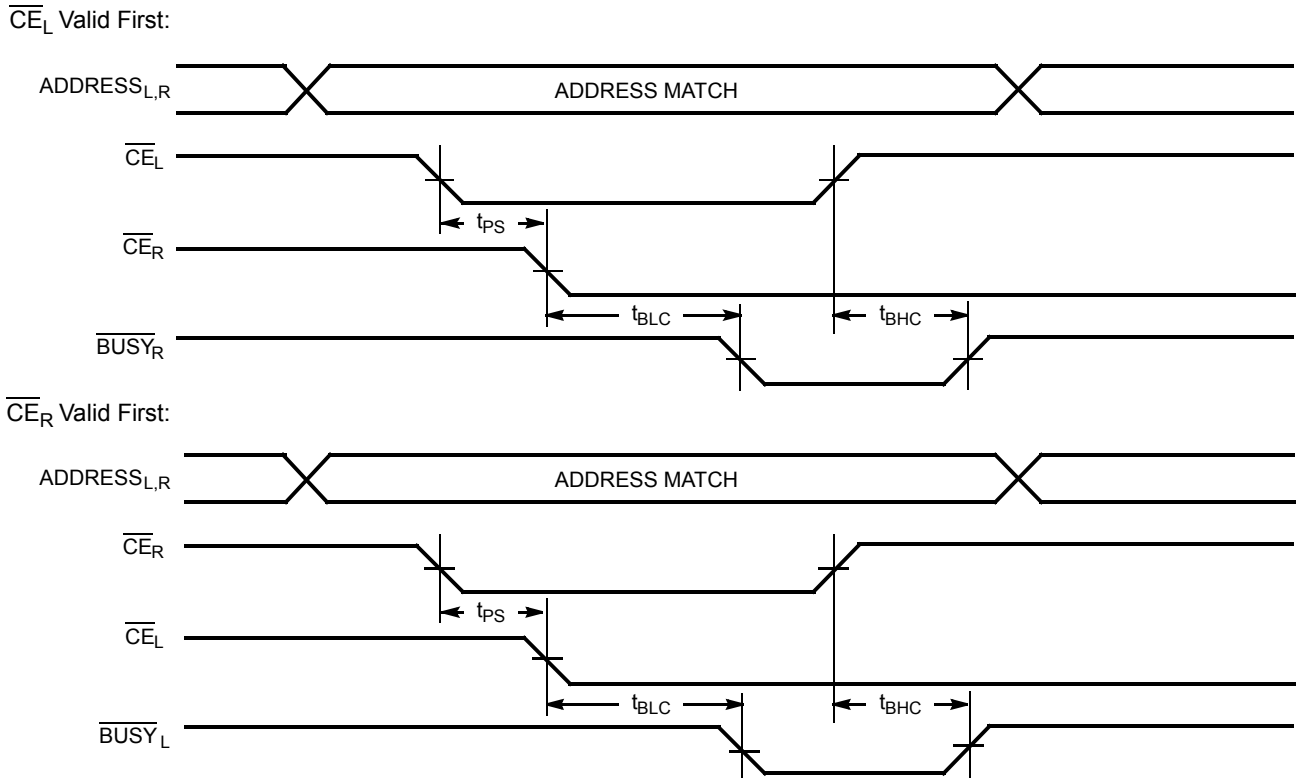
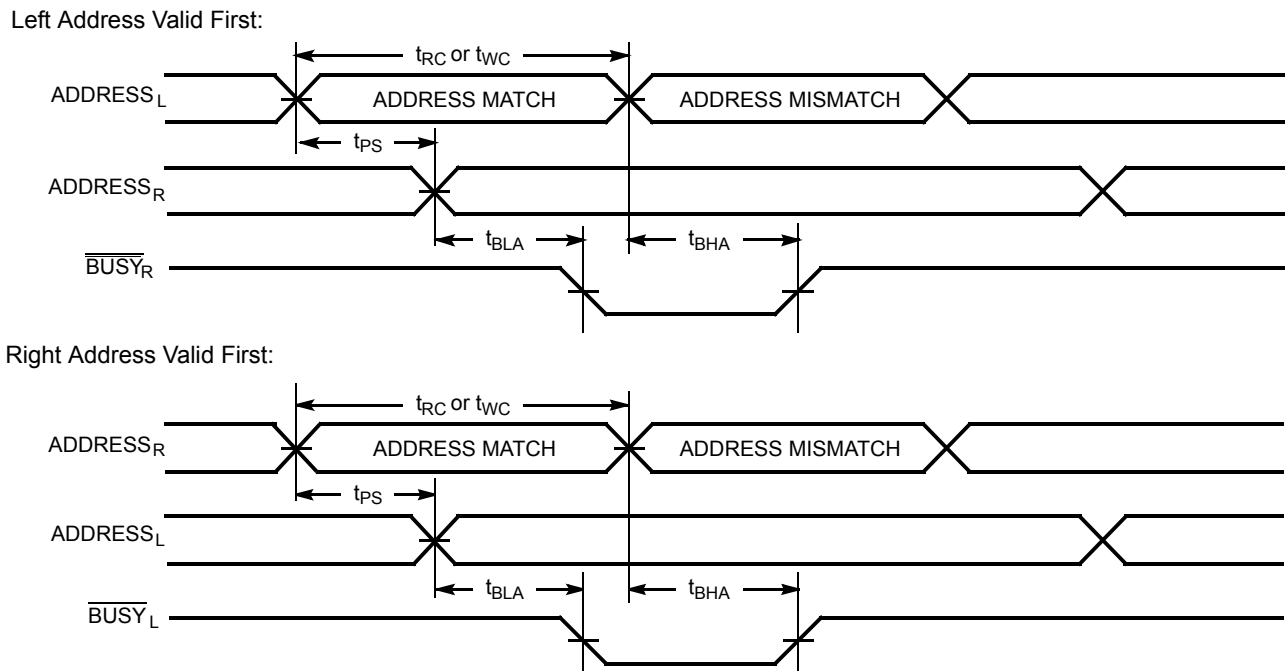

Figure 13. Busy Timing Diagram No. 2 (Address Arbitration)^[30]



Note

30. If t_{PS} is violated, the busy signal will be asserted on one side or the other, but there is no guarantee on which side $\overline{\text{BUSY}}$ will be asserted.

Switching Waveforms (continued)

Figure 14. Interrupt Timing Diagrams

Left Side Sets $\overline{\text{INT}}_R$:

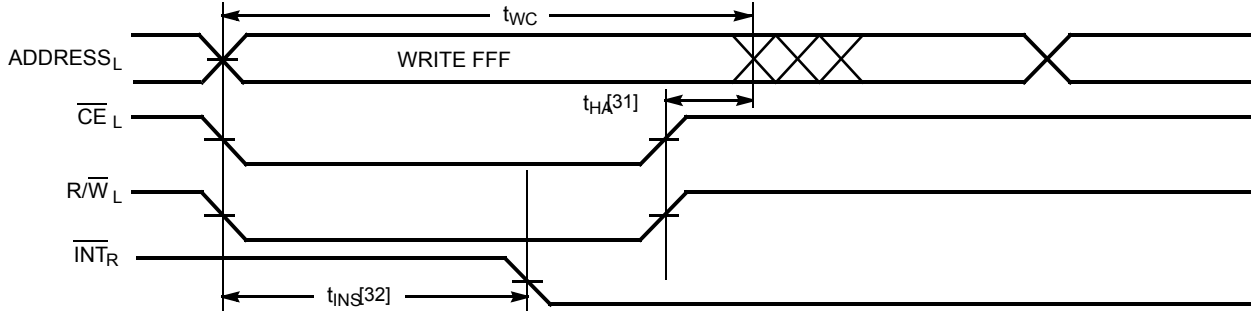

Right Side Clears $\overline{\text{INT}}_R$:

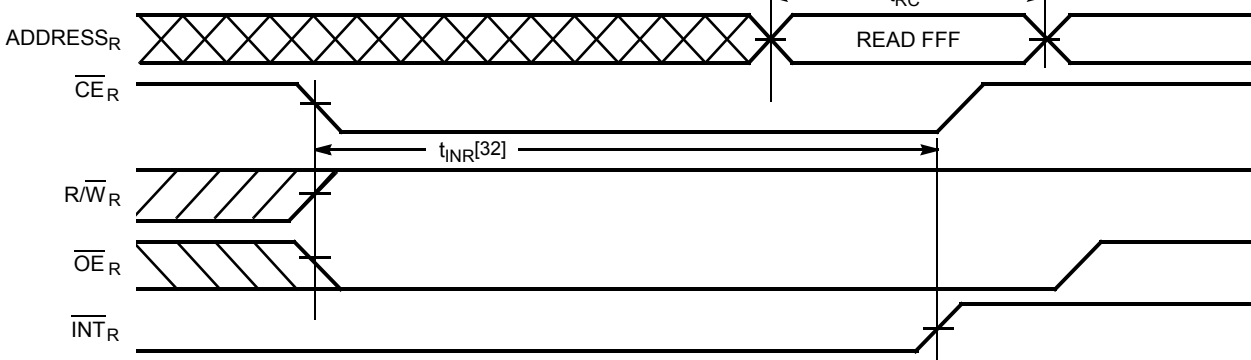

Right Side Sets $\overline{\text{INT}}_L$:

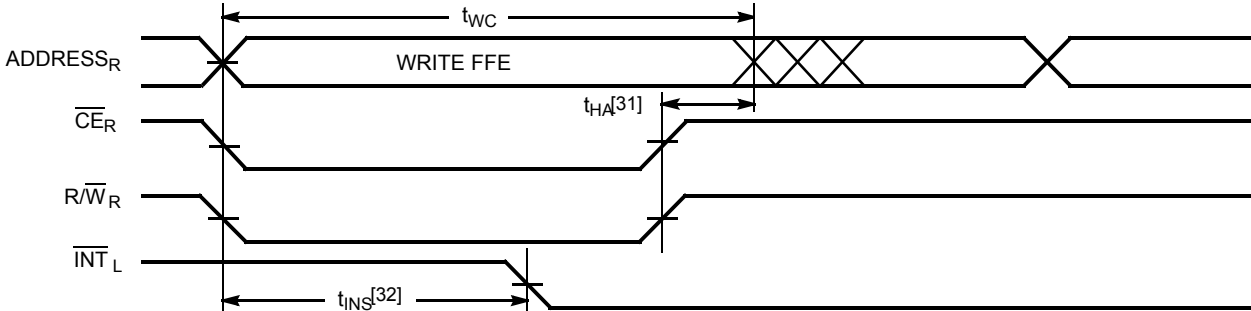

Left Side Clears $\overline{\text{INT}}_L$:

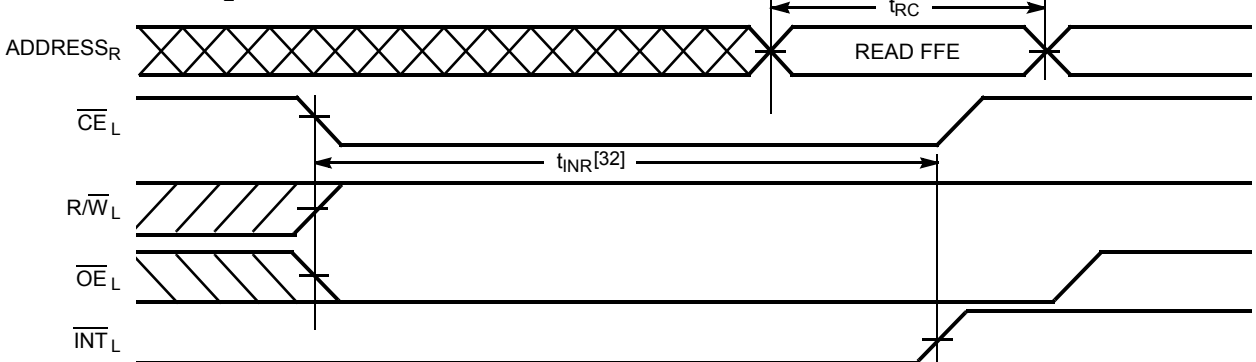

Notes

- 31. t_{HA} depends on which enable pin ($\overline{\text{CE}}_L$ or $\overline{\text{R}}/\overline{\text{W}}_L$) is deasserted first.
- 32. t_{INS} or t_{INR} depends on which enable pin ($\overline{\text{CE}}_L$ or $\overline{\text{R}}/\overline{\text{W}}_L$) is asserted last.

Architecture

The CY7C138/9 consists of an array of 4K words of 8/9 bits each of dual-port RAM cells, I/O and address lines, and control signals (\overline{CE} , \overline{OE} , R/W). These control pins permit independent access for reads or writes to any location in memory. To handle simultaneous writes and reads to the same location, a BUSY pin is provided on each port. Two interrupt (INT) pins can be used for port-to-port communication. Two semaphore (SEM) control pins are used for allocating shared resources. With the M/S pin, the CY7C138/9 can function as a master (BUSY pins are outputs) or as a slave (BUSY pins are inputs). The CY7C138/9 has an automatic power down feature controlled by \overline{CE} . Each port is provided with its own output enable control (\overline{OE}), which enables data to be read from the device.

Functional Description

Write Operation

Data must be set up for a duration of t_{SD} before the rising edge of R/W in order to guarantee a valid write. A write operation is controlled by either the \overline{OE} pin (see Write Cycle No. 1 waveform) or the R/W pin (see Write Cycle No. 2 waveform). Data can be written to the device t_{HZOE} after the \overline{OE} is deasserted or t_{HZWE} after the falling edge of R/W. Required inputs for non-contention operations are summarized in Table 3.

If a location is being written to by one port and the opposite port attempts to read that location, a port-to-port flowthrough delay must be met before the data is read on the output; otherwise the data read is not deterministic. Data is valid on the port t_{DD} after the data is presented on the other port.

Read Operation

When reading the device, the user must assert both the \overline{OE} and \overline{CE} pins. Data is available t_{ACE} after \overline{CE} or t_{DOE} after \overline{OE} is asserted. If the user of the CY7C138/9 wishes to access a semaphore flag, then the SEM pin must be asserted instead of the CE pin.

Interrupts

The interrupt flag (\overline{INT}) permits communications between ports. When the left port writes to location FFF, the right port's interrupt flag (\overline{INT}_R) is set. This flag is cleared when the right port reads that same location. Setting the left port's interrupt flag (\overline{INT}_L) is accomplished when the right port writes to location FFE. This flag is cleared when the left port reads location FFE. The message at FFF or FFE is user-defined. See Table 4 for input requirements for INT. \overline{INT}_R and \overline{INT}_L are push-pull outputs and do not require pull-up resistors to operate. $BUSY_L$ and $BUSY_R$ in master mode are push-pull outputs and do not require pull-up resistors to operate.

Busy

The CY7C138/9 provides on-chip arbitration to alleviate simultaneous memory location access (contention). If both ports' \overline{CE} s are asserted and an address match occurs within t_{PS} of each other the Busy logic determines which port has access. If t_{PS} is violated, one port definitely gains permission to the location, but it is not guaranteed which one. BUSY will be asserted t_{BLA} after an address match or t_{BLC} after CE is taken LOW.

Master/Slave

A M/S pin is provided to expand the word width by configuring the device as either a master or a slave. The BUSY output of the master is connected to the BUSY input of the slave. This enables the device to interface to a master device with no external components. Writing of slave devices must be delayed until after the BUSY input has settled. Otherwise, the slave chip may begin a write cycle during a contention situation. When presented as a HIGH input, the M/S pin allows the device to be used as a master and therefore the BUSY line is an output. BUSY can then be used to send the arbitration outcome to a slave.

Semaphore Operation

The CY7C138/9 provides eight semaphore latches, which are separate from the dual-port memory locations. Semaphores are used to reserve resources that are shared between the two ports. The state of the semaphore indicates that a resource is in use. For example, if the left port wants to request a resource, it sets a latch by writing a zero to a semaphore location. The left port then verifies its success in setting the latch by reading it. After writing to the semaphore, SEM or OE must be deasserted for t_{SOP} before attempting to read the semaphore. The semaphore value is available $t_{SWRD} + t_{DOE}$ after the rising edge of the semaphore write. If the left port was successful (reads a zero), it assumes control over the shared resource, otherwise (reads a one) it assumes the right port has control and continues to poll the semaphore. When the right side has relinquished control of the semaphore (by writing a one), the left side succeeds in gaining control of the semaphore. If the left side no longer requires the semaphore, a 1 is written to cancel its request.

Semaphores are accessed by asserting SEM LOW. The SEM pin functions as a chip enable for the semaphore latches (\overline{CE} must remain HIGH during SEM LOW). A_{0-2} represents the semaphore address. OE and R/W are used in the same manner as a normal memory access. When writing or reading a semaphore, the other address pins have no effect.

When writing to the semaphore, only I/O₀ is used. If a zero is written to the left port of an unused semaphore, a one will appear at the same semaphore address on the right port. That semaphore can now only be modified by the side showing zero (the left port in this case). If the left port now relinquishes control by writing a one to the semaphore, the semaphore is set to 1 for both sides. However, if the right port had requested the semaphore (written a zero) while the left port had control, the right port immediately owns the semaphore after the left port releases it. Table 5 shows sample semaphore operations.

When reading a semaphore, all eight or nine data lines output the semaphore value. The read value is latched in an output register to prevent the semaphore from changing state during a write from the other port. If both ports attempt to access the semaphore within t_{SPS} of each other, the semaphore is definitely obtained by one side or the other, but there is no guarantee which side controls the semaphore.

Initialization of the semaphore is not automatic and must be reset during initialization program at power up. All semaphores on both sides should have a 1 written into them at initialization from both sides to assure that they are free when needed.

Table 3. Non-Contending Read/Write

Inputs				Outputs	Operation
CE	R/W	OE	SEM	I/O _{0-7/8}	
H	X	X	H	High Z	Power Down
H	H	L	L	Data Out	Read Data in Semaphore
X	X	H	X	High Z	I/O Lines Disabled
H		X	L	Data In	Write to Semaphore
L	H	L	H	Data Out	Read
L	L	X	H	Data In	Write
L	X	X	L		Illegal Condition

Table 4. Interrupt Operation Example (assumes $\overline{\text{BUSY}}_L = \overline{\text{BUSY}}_R = \text{HIGH}$)

Function	Left Port					Right Port				
	R/W	CE	OE	A ₀₋₁₁	INT	R/W	CE	OE	A ₀₋₁₁	INT
Set Left $\overline{\text{INT}}$	X	X	X	X	L	L	L	X	FFE	X
Reset Left $\overline{\text{INT}}$	X	L	L	FFE	H	X	X	X	X	X
Set Right $\overline{\text{INT}}$	L	L	X	FFF	X	X	X	X	X	L
Reset Right $\overline{\text{INT}}$	X	X	X	X	X	X	L	L	FFF	H

Table 5. Semaphore Operation Example

Function	I/O _{0-7/8} Left	I/O _{0-7/8} Right	Status
No action	1	1	Semaphore free
Left port writes semaphore	0	1	Left port obtains semaphore
Right port writes 0 to semaphore	0	1	Right side is denied access
Left port writes 1 to semaphore	1	0	Right port is granted access to semaphore
Left port writes 0 to semaphore	1	0	No change. Left port is denied access
Right port writes 1 to semaphore	0	1	Left port obtains semaphore
Left port writes 1 to semaphore	1	1	No port accessing semaphore address
Right port writes 0 to semaphore	1	0	Right port obtains semaphore
Right port writes 1 to semaphore	1	1	No port accessing semaphore
Left port writes 0 to semaphore	0	1	Left port obtains semaphore
Left port writes 1 to semaphore	1	1	No port accessing semaphore

Figure 15. Typical DC and AC Characteristics

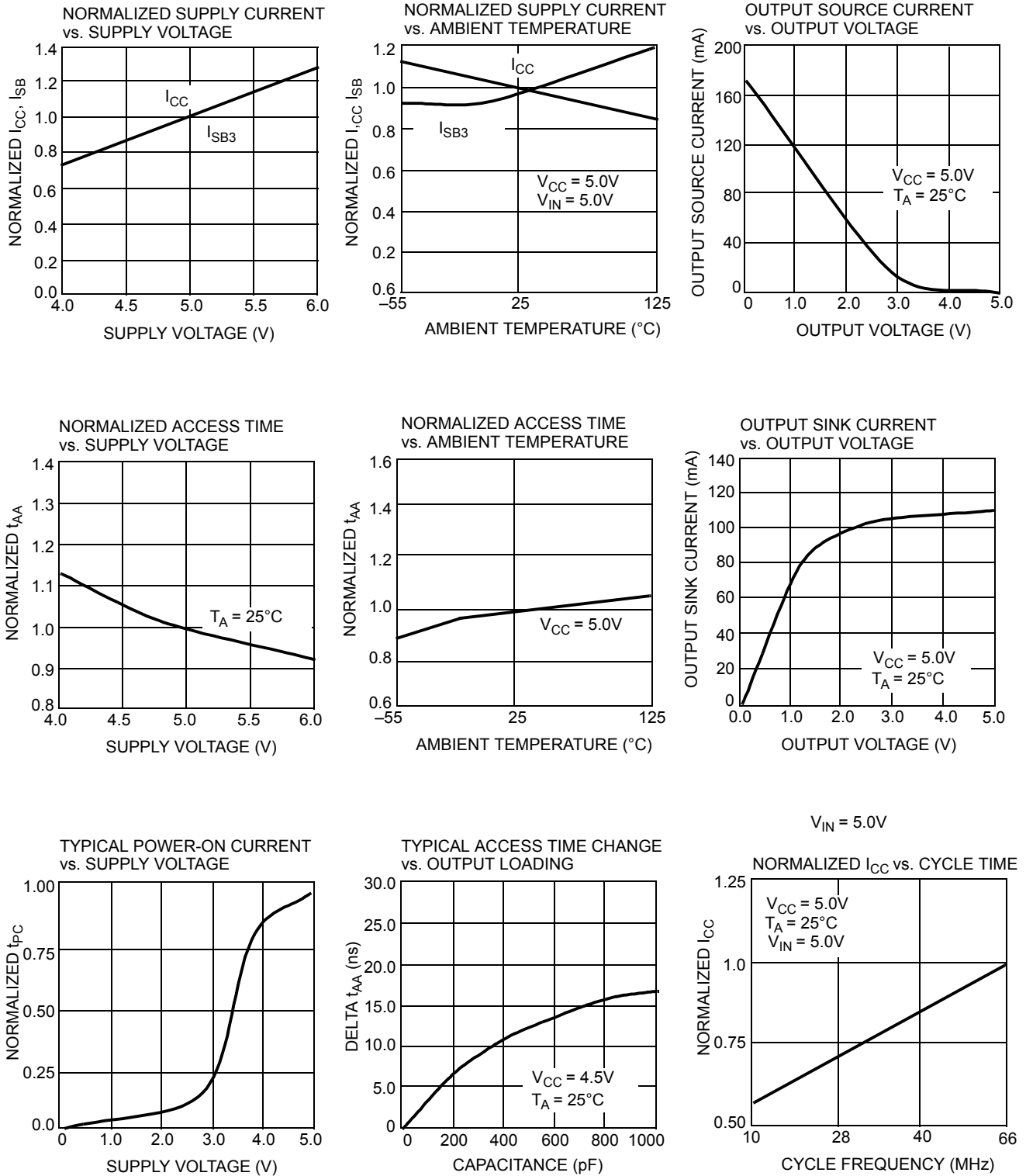

Ordering Information

4K x8 Dual-Port SRAM

Speed (ns)	Ordering Code	Package Diagram	Package Type	Operating Range
15	CY7C138-15JC	51-85005	68-Pin Plastic Leaded Chip Carrier	Commercial
	CY7C138-15JXC	51-85005	68-Pin Plastic Leaded Chip Carrier (Pb-free)	
25	CY7C138-25JC	51-85005	68-Pin Plastic Leaded Chip Carrier	Commercial
	CY7C138-25JXC	51-85005	68-Pin Plastic Leaded Chip Carrier (Pb-free)	
	CY7C138-25JI	51-85005	68-Pin Plastic Leaded Chip Carrier	Industrial
	CY7C138-25JXI	51-85005	68-Pin Plastic Leaded Chip Carrier (Pb-free)	
35	CY7C138-35JC	51-85005	68-Pin Plastic Leaded Chip Carrier	Commercial
	CY7C138-35JI	51-85005	68-Pin Plastic Leaded Chip Carrier	Industrial
55	CY7C138-55JC	51-85005	68-Pin Plastic Leaded Chip Carrier	Commercial
	CY7C138-55JI	51-85005	68-Pin Plastic Leaded Chip Carrier	Industrial

Package Diagram

Figure 16. 68-Pin Plastic Leaded Chip Carrier (51-85005)

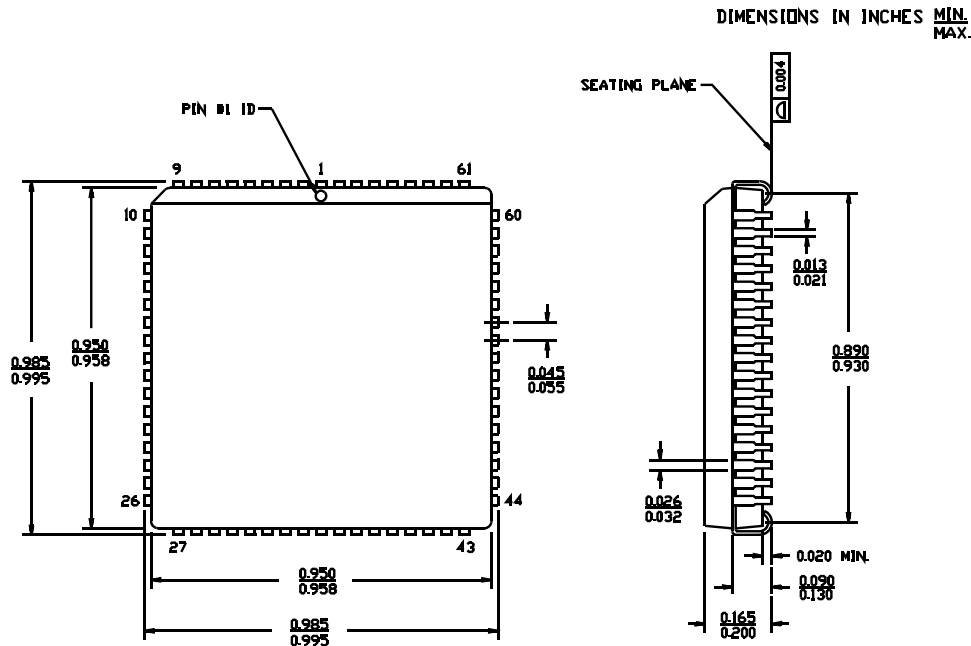

51-85005-A

Document History Page

Document Title: CY7C138, CY7C139 4K x 8/9 Dual-Port Static RAM with Sem, Int, Busy Document Number: 38-06037				
Rev.	ECN No.	Orig. of Change	Submission Date	Description of Change
**	110180	SZV	09/29/01	Change from Spec number: 38-00536 to 38-06037
*A	122287	RBI	12/27/02	Power up requirements added to Maximum Ratings Information
*B	393403	YIM	See ECN	Added Pb-Free Logo Added Pb-Free parts to ordering information: CY7C138-15JXC, CY7C138-25JXC, CY7C139-25JXC
*C	2623658	VKN/PYRS	12/17/08	Added CY7C138-25JXI part Removed CY7C139 from the Ordering information table
*D	2672737	GNKK	03/12/2009	Corrected title in the Document History table
*E	2714768	VKN/AESA	06/04/2009	Corrected defective Logic Block diagram, Pinouts and Package diagrams

Sales, Solutions, and Legal Information

Worldwide Sales and Design Support

Cypress maintains a worldwide network of offices, solution centers, manufacturer’s representatives, and distributors. To find the office closest to you, visit us at cypress.com/sales.

Products

- PSoC psoc.cypress.com
- Clocks & Buffers clocks.cypress.com
- Wireless wireless.cypress.com
- Memories memory.cypress.com
- Image Sensors image.cypress.com

© Cypress Semiconductor Corporation, 2005-2009. The information contained herein is subject to change without notice. Cypress Semiconductor Corporation assumes no responsibility for the use of any circuitry other than circuitry embodied in a Cypress product. Nor does it convey or imply any license under patent or other rights. Cypress products are not warranted nor intended to be used for medical, life support, life saving, critical control or safety applications, unless pursuant to an express written agreement with Cypress. Furthermore, Cypress does not authorize its products for use as critical components in life-support systems where a malfunction or failure may reasonably be expected to result in significant injury to the user. The inclusion of Cypress products in life-support systems application implies that the manufacturer assumes all risk of such use and in doing so indemnifies Cypress against all charges.

Any Source Code (software and/or firmware) is owned by Cypress Semiconductor Corporation (Cypress) and is protected by and subject to worldwide patent protection (United States and foreign), United States copyright laws and international treaty provisions. Cypress hereby grants to licensee a personal, non-exclusive, non-transferable license to copy, use, modify, create derivative works of, and compile the Cypress Source Code and derivative works for the sole purpose of creating custom software and or firmware in support of licensee product to be used only in conjunction with a Cypress integrated circuit as specified in the applicable agreement. Any reproduction, modification, translation, compilation, or representation of this Source Code except as specified above is prohibited without the express written permission of Cypress.

Disclaimer: CYPRESS MAKES NO WARRANTY OF ANY KIND, EXPRESS OR IMPLIED, WITH REGARD TO THIS MATERIAL, INCLUDING, BUT NOT LIMITED TO, THE IMPLIED WARRANTIES OF MERCHANTABILITY AND FITNESS FOR A PARTICULAR PURPOSE. Cypress reserves the right to make changes without further notice to the materials described herein. Cypress does not assume any liability arising out of the application or use of any product or circuit described herein. Cypress does not authorize its products for use as critical components in life-support systems where a malfunction or failure may reasonably be expected to result in significant injury to the user. The inclusion of Cypress’ product in a life-support systems application implies that the manufacturer assumes all risk of such use and in doing so indemnifies Cypress against all charges.

Use may be limited by and subject to the applicable Cypress software license agreement.