



# W2G115 Series Tubeaxial

127x127x38mm

- DC fans with electronically commutated external rotor motor. Fully integrated commutation electronics.
- With electronic protection against reverse polarity and locked-rotor.
- Mounting from either face using four 4.7 mm holes.
- Die-cast aluminum housing. Impeller of sheet-steel, directly welded onto rotor and stove-enameled.
- Air exhaust over struts. Rotational direction CCW looking at rotor.
- Electrical connection via 2 flat pins 2.8 x 0.8 mm.
- UL, CSA, VDE approvals on some models, please contact application engineering.

| Part Number    | CFM @ 0 | Curve | Volts | Voltage Range | Power (W) | dBA | Max Ambient Temp C | Wgt. (lbs) | Type Of Bearing | Features  |
|----------------|---------|-------|-------|---------------|-----------|-----|--------------------|------------|-----------------|-----------|
| W2G115-AD15-01 | 118     | 1     | 12    | 8 to 16       | 4.5       | 44  | 72                 | 1.31       | Ball            | Leads     |
| W2G115-AD15-13 | 118     | 1     | 12    | 8 to 16       | 4.5       | 44  | 72                 | 1.31       | Ball            | Terminals |
| W2G115-AE53-01 | 130     | 2     | 12    | 8 to 16       | 5.9       | 48  | 72                 | 1.56       | Ball            | Leads     |
| W2G115-AE53-13 | 130     | 2     | 12    | 8 to 16       | 5.9       | 48  | 72                 | 1.56       | Ball            | Terminals |
| W2G115-AD17-01 | 118     | 1     | 24    | 18 to 30      | 4.7       | 44  | 72                 | 1.31       | Ball            | Leads     |
| W2G115-AD17-13 | 118     | 1     | 24    | 18 to 30      | 4.7       | 44  | 72                 | 1.31       | Ball            | Leads     |
| W2G115-AE31-01 | 130     | 2     | 24    | 18 to 30      | 5.7       | 48  | 72                 | 1.56       | Ball            | Leads     |
| W2G115-AE31-13 | 130     | 2     | 24    | 18 to 30      | 5.7       | 48  | 72                 | 1.56       | Ball            | Terminals |
| W2G115-AG71-01 | 160     | 3     | 24    | 16 to 28      | 12.0      | 52  | 72                 | 1.56       | Ball            | Leads     |
| W2G115-AG71-12 | 160     | 3     | 24    | 16 to 28      | 12.0      | 52  | 72                 | 1.56       | Ball            | Terminals |
| W2G115-AD19-01 | 118     | 1     | 48    | 36 to 56      | 4.6       | 44  | 72                 | 1.31       | Ball            | Leads     |

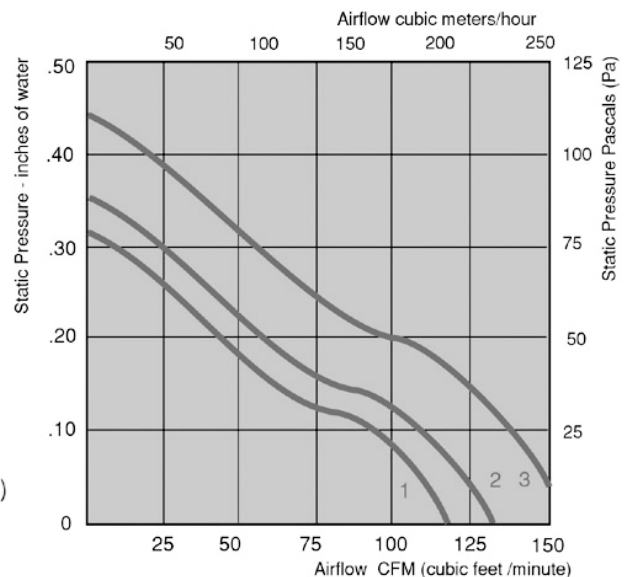
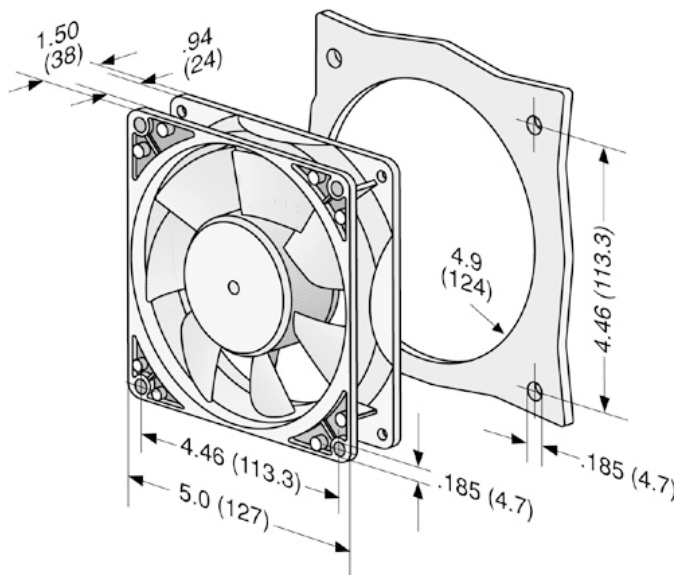

e-mail: [sales@ebm.com](mailto:sales@ebm.com) • TEL: 860-674-1515 • FAX: 860-674-8536  
 ebm Industries, Inc., 100 Hyde Road, Farmington, CT 06034 USA

ebm Industries, Inc., 2003 © ebm Industries, Inc. reserves the right to change any specifications or data without notice