

MSC8126

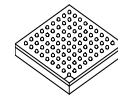

FC PBGA-431
20 mm × 20 mm

Quad Digital Signal Processor

- Four StarCore™ SC140 DSP extended cores, each with an SC140 DSP core, 224 Kbyte of internal SRAM M1 memory (1436 Kbyte total), 16 way 16 Kbyte instruction cache (ICache), four-entry write buffer, external cache support, programmable interrupt controller (PIC), local interrupt controller (LIC), and low-power Wait and Stop processing modes.
- 475 Kbyte M2 memory for critical data/temporary data buffering.
- 4 Kbyte boot ROM.
- M2-accessible multi-core MQBus connecting the M2 memory with all four cores, operating at the core frequency, with data bus access of up to 128-bit reads and up to 64-bit writes, central efficient round-robin arbiter for core access to the bus, and atomic control of M2 memory access by the cores and local bus.
- Internal PLL configured are reset by configuration signal values.
- 60x-compatible system bus with 64 or 32 bit data and 32-bit address bus, support for multi-master designs, four-beat burst transfers (eight-beat in 32-bit data mode), port size of 64/32/16/8 bits controlled by the internal memory controller..access to external memory or peripherals, access by an external host to internal resources, slave support with direct access to internal resources including M1 and M2 memories, and on-device arbitration for up to four master devices.
- Direct slave interface (DSI) using a 32/64-bit slave interface with 21–25 bit addressing and 32/64-bit data transfers, direct access by an external host to internal/external resources, synchronous or asynchronous accesses with burst capability in synchronous mode, dual or single strobe mode, write and read buffers to improve host bandwidth, byte enable signals for 1/2/4/8-byte write granularity, sliding window mode for access using a reduced number of address pins, chip ID decoding to allow one \overline{CS} signal to control multiple DSPs, broadcast mode to write to multiple DSPs, and big-endian/little-endian/munged support.
- Three mode signal multiplexing: 64-bit DSI/32-bit system bus, 32-bit DSI/64-bit system bus, or 32-bit DSI/32-bit system bus.
- Flexible memory controller with three UPMs, a GPCM, a page-mode SDRAM machine, glueless interface to a variety of memories and devices, byte enables for 64-/32-bit bus widths, 8 memory banks for external memories, and 2 memory banks for IPBus peripherals and internal memories.
- Multi-channel DMA controller with 16 time-multiplexed single channels, up to four external peripherals, \overline{DONE} or \overline{DRACK} protocol for two external peripherals,.service for up to 16 internal requests from up to 8 internal FIFOs per channel, FIFO generated watermarks and hungry requests, priority-based time-multiplexing between channels using 16 internal priority levels or round-robin time-multiplexing between channels, flexible channel configuration with connection to local bus or system bus, and flyby transfer support that bypasses the FIFO.
- Up to four independent TDM modules with programmable word size (2, 4, 8, or 16-bit), hardware-base A-law/ μ -law conversion, up to 128 Mbps data rate for all channels, with glueless interface to E1 or T1 framers, and can interface with H-MVIP/H.110 devices, TSI, and codecs such as AC-97.
- Ethernet controller: support for 10/100 Mbps MII/RMII/SMII including full- and half-duplex operation, full-duplex flow controls, out-of-sequence transmit queues, programmable maximum frame length including jumbo frames and VLAN tags and priority, retransmission after collision, CRC generation and verification of inbound/outbound packets, address recognition (including exact match, broadcast address, individual hash check, group hash check, and promiscuous mode), pattern matching, insertion with expansion or replacement for transmit frames, VLAN tag insertion, RMON statistics, local bus master DMA for descriptor fetching and buffer access, and optional multiplexing with GPIO (MII/RMII/SMII) or DSI/system bus signals lines (MII/RMII).
- UART with full-duplex operation up to 6.25 Mbps.
- Up to 32 general-purpose input/output (GPIO) ports.
- I²C interface that allows booting from EEPROM devices.
- Two timer modules, each with sixteen configurable 16-bit timers.
- Eight programmable hardware semaphores.
- Global interrupt controller (GIC) with interrupt consolidation and routing to $\overline{INT_OUT}$, $\overline{NMI_OUT}$, and the cores; thirty-two virtual maskable interrupts (8 per core) and four virtual \overline{NMI} (one per core) that can be generated by a simple write access.
- Boot options: external memory, external host, UART, TDM, or I²C.
- VCOP with fully programmable feed-forward channel decoding, feed-forward channel equalization and traceback sessions. Up to 400 3GPP 12.2 kbps AMR channels (channel decoding, number of channels linear to frequency). Up to 200 blind transport format detect (BTFD) channels according to the 3GPP standard. Number of channels linear to frequency.
- TCOP with full support for 3GPP and CDMA2000 standards in Turbo decode; up to 20 turbo-coding 384 kbps channels; 8 state PCCC with polynomial as supported by the 3G standards; iterative decoding structure based on Maximum A-Posteriori probability (MAP), with calculations performed in the LOG domain.

Table of Contents

1	Pin Assignments	4
1.1	FC-PBGA Ball Layout Diagrams	4
1.2	Signal List By Ball Location	7
2	Electrical Characteristics	13
2.1	Maximum Ratings	13
2.2	Recommended Operating Conditions	14
2.3	Thermal Characteristics	14
2.4	DC Electrical Characteristics	15
2.5	AC Timings	16
3	Hardware Design Considerations	40
3.1	Start-up Sequencing Recommendations	40
3.2	Power Supply Design Considerations	40
3.3	Connectivity Guidelines	42
3.4	External SDRAM Selection	43
3.5	Thermal Considerations	44
4	Ordering Information	44
5	Package Information	45
6	Product Documentation	45
7	Revision History	46

List of Figures

Figure 1.	MSC8126 Block Diagram	3
Figure 2.	StarCore SC140 DSP Extended Core Block Diagram	3
Figure 3.	MSC8126 Package, Top View	5
Figure 4.	MSC8126 Package, Bottom View	6
Figure 5.	Overshoot/Undershoot Voltage for V_{IH} and V_{IL}	16
Figure 6.	Start-Up Sequence: V_{DD} and V_{DDH} Raised Together	17
Figure 7.	Start-Up Sequence: V_{DD} Raised Before V_{DDH} with CLKIN Started with V_{DDH}	17
Figure 8.	Power-Up Sequence for V_{DDH} and V_{DD}/V_{CCSYN}	18

Figure 9.	Timing Diagram for a Reset Configuration Write	21
Figure 10.	Internal Tick Spacing for Memory Controller Signals	22
Figure 11.	SIU Timing Diagram	25
Figure 12.	CLKOUT and CLKIN Signals	26
Figure 13.	DMA Signals	27
Figure 14.	Asynchronous Single- and Dual-Strobe Modes Read Timing Diagram	29
Figure 15.	Asynchronous Single- and Dual-Strobe Modes Write Timing Diagram	30
Figure 16.	Asynchronous Broadcast Write Timing Diagram	30
Figure 17.	DSI Synchronous Mode Signals Timing Diagram	31
Figure 18.	TDM Inputs Signals	32
Figure 19.	TDM Output Signals	32
Figure 20.	UART Input Timing	33
Figure 21.	UART Output Timing	33
Figure 22.	Timer Timing	34
Figure 23.	MDIO Timing Relationship to MDC	34
Figure 24.	MII Mode Signal Timing	35
Figure 26.	SMII Mode Signal Timing	36
Figure 27.	GPIO Timing	37
Figure 28.	EE Pin Timing	37
Figure 29.	Test Clock Input Timing Diagram	38
Figure 30.	Boundary Scan (JTAG) Timing Diagram	38
Figure 31.	Test Access Port Timing Diagram	39
Figure 32.	TRST Timing Diagram	39
Figure 33.	Core Power Supply Decoupling	41
Figure 34.	V_{CCSYN} Bypass	41
Figure 35.	MSC8126 Mechanical Information, 431-pin FC-PBGA Package	45

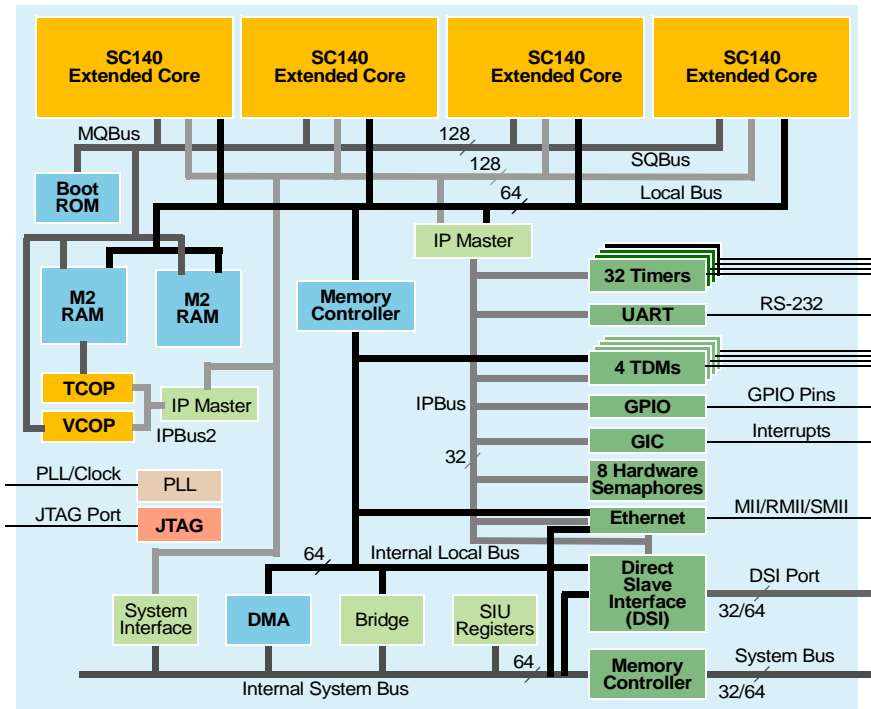
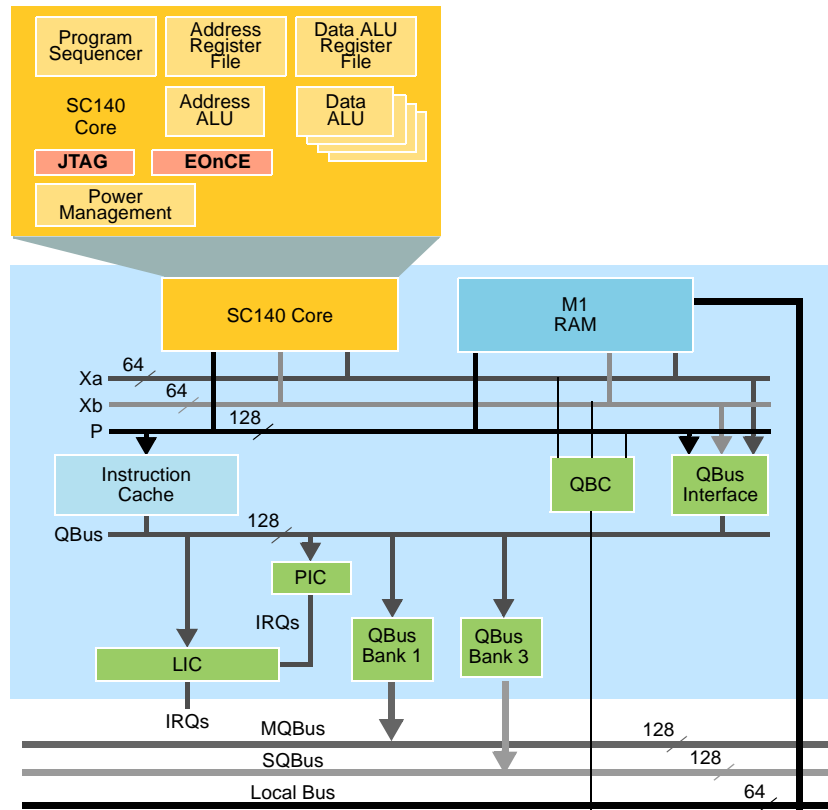

Figure 1. MSC8126 Block Diagram



Notes: 1. The arrows show the data transfer direction.
 2. The QBus interface includes a bus switch, write buffer, fetch unit, and a control unit that defines four QBus banks. In addition, the QBC handles internal memory contentions.

Figure 2. StarCore SC140 DSP Extended Core Block Diagram

1 Pin Assignments

This section includes diagrams of the MSC8126 package ball grid array layouts and pinout allocation tables.

1.1 FC-PBGA Ball Layout Diagrams

Top and bottom views of the FC-PBGA package are shown in **Figure 3** and **Figure 4** with their ball location index numbers.

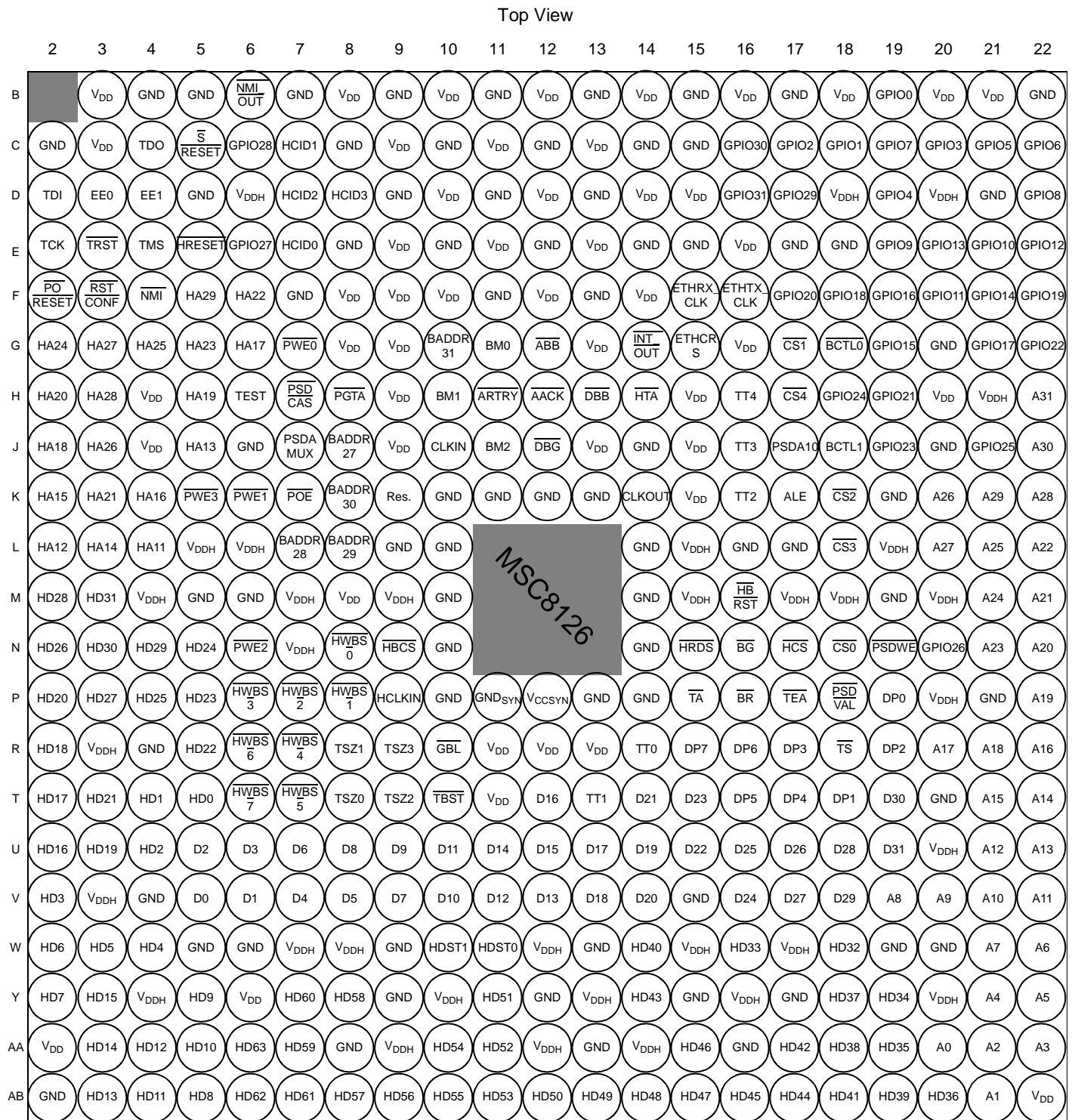

Figure 3. MSC8126 Package, Top View

Pin Assignments

Bottom View

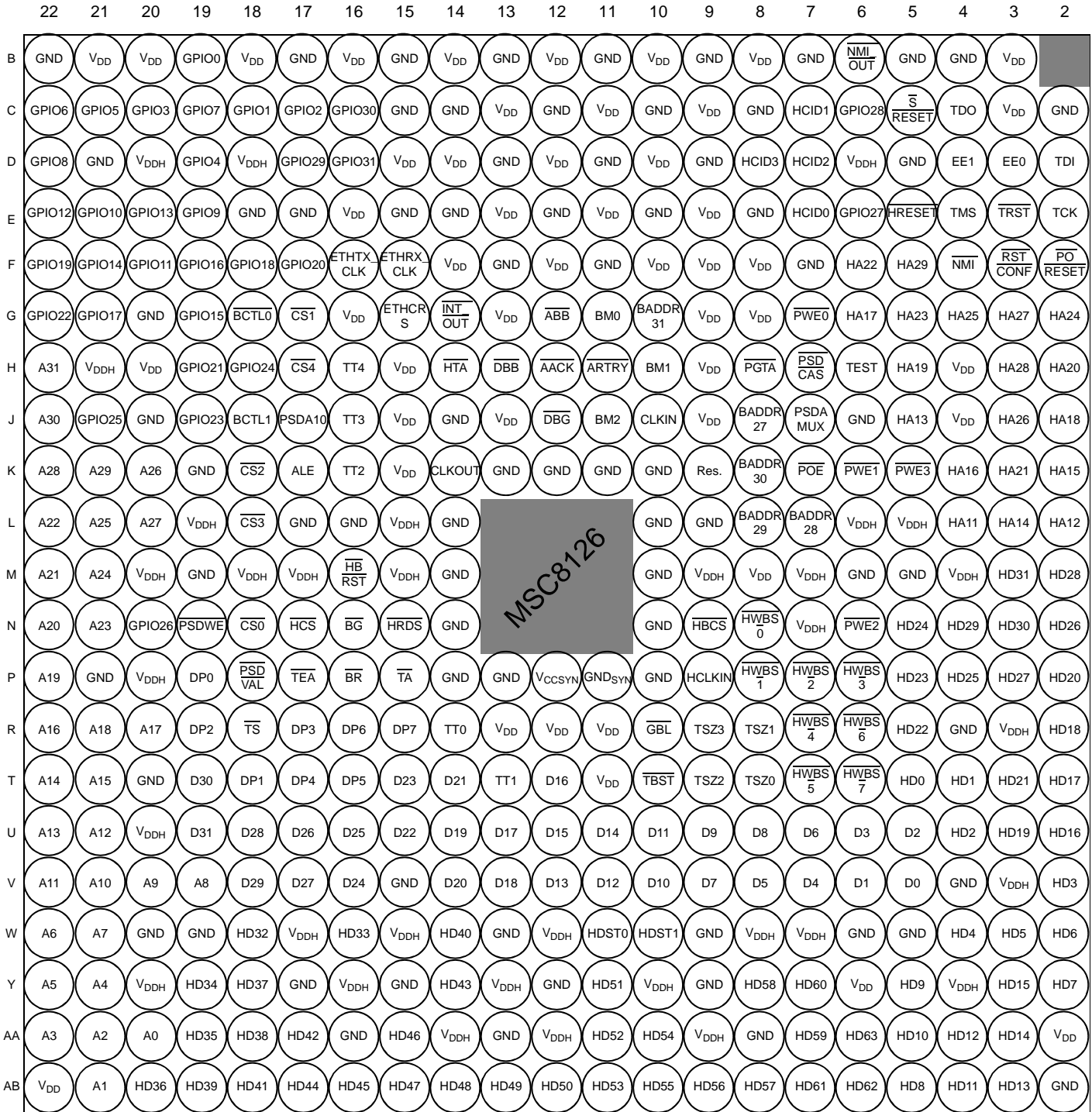

Figure 4. MSC8126 Package, Bottom View

1.2 Signal List By Ball Location

Table 1 presents signal list sorted by ball number. -

Table 1. MSC8126 Signal Listing by Ball Designator

Des.	Signal Name	Des.	Signal Name
B3	V _{DD}	C18	GPIO1/TIMER0/CHIP_ID1/IRQ5/ETHTXD1
B4	GND	C19	GPIO7/TDM3RCLK/IRQ5/ETHTXD3
B5	GND	C20	GPIO3/TDM3TSYN/IRQ1/ETHTXD2
B6	NMI_OUT	C21	GPIO5/TDM3TDAT/IRQ3/ETHRXD3
B7	GND	C22	GPIO6/TDM3RSYN/IRQ4/ETHRXD2
B8	V _{DD}	D2	TDI
B9	GND	D3	EE0
B10	V _{DD}	D4	EE1
B11	GND	D5	GND
B12	V _{DD}	D6	V _{DDH}
B13	GND	D7	HCID2
B14	V _{DD}	D8	HCID3/HA8
B15	GND	D9	GND
B16	V _{DD}	D10	V _{DD}
B17	GND	D11	GND
B18	V _{DD}	D12	V _{DD}
B19	GPIO0/CHIP_ID0/IRQ4/ETHTXD0	D13	GND
B20	V _{DD}	D14	V _{DD}
B21	V _{DD}	D15	V _{DD}
B22	GND	D16	GPIO31/TIMER3/SCL
C2	GND	D17	GPIO29/CHIP_ID3/ETHTX_EN
C3	V _{DD}	D18	V _{DDH}
C4	TDO	D19	GPIO4/TDM3TCLK/IRQ2/ETHTX_ER
C5	SRESET	D20	V _{DDH}
C6	GPIO28/DREQ2/UTXD	D21	GND
C7	HCID1	D22	GPIO8/TDM3RDAT/IRQ6/ETHCOL
C8	GND	E2	TCK
C9	V _{DD}	E3	TRST
C10	GND	E4	TMS
C11	V _{DD}	E5	HRESET
C12	GND	E6	GPIO27/DREQ1/URXD
C13	V _{DD}	E7	HCID0
C14	GND	E8	GND
C15	GND	E9	V _{DD}
C16	GPIO30/TIMER2/TMCLK/SDA	E10	GND
C17	GPIO2/TIMER1/CHIP_ID2/IRQ6	E11	V _{DD}

Table 1. MSC8126 Signal Listing by Ball Designator (continued)

Des.	Signal Name	Des.	Signal Name
E12	GND	G6	HA17
E13	V _{DD}	G7	$\overline{\text{PWE0/PSDDQM0/PBS0}}$
E14	GND	G8	V _{DD}
E15	GND	G9	V _{DD}
E16	V _{DD}	G10	$\overline{\text{IRQ3/BADDR31}}$
E17	GND	G11	BM0/TC0/BNKSEL0
E18	GND	G12	$\overline{\text{ABB/IRQ4}}$
E19	GPIO9/TDM2TSYN/ $\overline{\text{IRQ7/ETHMDIO}}$	G13	V _{DD}
E20	GPIO13/TDM2RCLK/ $\overline{\text{IRQ11/ETHMDC}}$	G14	$\overline{\text{IRQ7/INT_OUT}}$
E21	GPIO10/TDM2TCLK/ $\overline{\text{IRQ8/ETHRX_DV/ETHCRS_DV/NC}}$	G15	ETHCRS/ETHRXD
E22	GPIO12/TDM2RSYN/ $\overline{\text{IRQ10/ETHRXD1/ETHSYNC}}$	G16	V _{DD}
F2	$\overline{\text{PORESET}}$	G17	$\overline{\text{CS1}}$
F3	$\overline{\text{RSTCONF}}$	G18	$\overline{\text{BCTL0}}$
F4	$\overline{\text{NMI}}$	G19	GPIO15/TDM1TSYN/DREQ1
F5	HA29	G20	GND
F6	HA22	G21	GPIO17/TDM1TDAT/ $\overline{\text{DACK1}}$
F7	GND	G22	GPIO22/TDM0TCLK/ $\overline{\text{DONE2/DRACK2}}$
F8	V _{DD}	H2	HA20
F9	V _{DD}	H3	HA28
F10	V _{DD}	H4	V _{DD}
F11	GND	H5	HA19
F12	V _{DD}	H6	TEST
F13	GND	H7	$\overline{\text{PSDCAS/PGPL3}}$
F14	V _{DD}	H8	$\overline{\text{PGTA/PUPMWAIT/PGPL4/PPBS}}$
F15	ETHRX_CLK/ETHSYNC_IN	H9	V _{DD}
F16	ETHTX_CLK/ETHREF_CLK/ETHCLOCK	H10	BM1/TC1/BNKSEL1
F17	GPIO20/TDM1RDAT	H11	$\overline{\text{ARTRY}}$
F18	GPIO18/TDM1RSYN/DREQ2	H12	$\overline{\text{AACK}}$
F19	GPIO16/TDM1TCLK/ $\overline{\text{DONE1/DRACK1}}$	H13	$\overline{\text{DBB/IRQ5}}$
F20	GPIO11/TDM2TDAT/ $\overline{\text{IRQ9/ETHRX_ER/ETHTXD}}$	H14	$\overline{\text{HTA}}$
F21	GPIO14/TDM2RDAT/ $\overline{\text{IRQ12/ETHRXD0/NC}}$	H15	V _{DD}
F22	GPIO19/TDM1RCLK/ $\overline{\text{DACK2}}$	H16	TT4/ $\overline{\text{CS7}}$
G2	HA24	H17	$\overline{\text{CS4}}$
G3	HA27	H18	GPIO24/TDM0RSYN/ $\overline{\text{IRQ14}}$
G4	HA25	H19	GPIO21/TDM0TSYN
G5	HA23	H20	V _{DD}
H21	V _{DDH}	K15	V _{DD}
H22	A31	K16	TT2/ $\overline{\text{CS5}}$
J2	HA18	K17	ALE

Table 1. MSC8126 Signal Listing by Ball Designator (continued)

Des.	Signal Name	Des.	Signal Name
J3	HA26	K18	$\overline{CS2}$
J4	V_{DD}	K19	GND
J5	HA13	K20	A26
J6	GND	K21	A29
J7	PSDAMUX/PGPL5	K22	A28
J8	BADDR27	L2	HA12
J9	V_{DD}	L3	HA14
J10	CLKIN	L4	HA11
J11	BM2/TC2/BNKSEL2	L5	V_{DDH}
J12	\overline{DBG}	L6	V_{DDH}
J13	V_{DD}	L7	BADDR28
J14	GND	L8	$\overline{IRQ5/BADDR29}$
J15	V_{DD}	L9	GND
J16	TT3/ $\overline{CS6}$	L10	GND
J17	PSDA10/PGPL0	L14	GND
J18	$\overline{BCTL1/CS5}$	L15	V_{DDH}
J19	GPIO23/TDM0TDAT/ $\overline{IRQ13}$	L16	GND
J20	GND	L17	GND
J21	GPIO25/TDM0RCLK/ $\overline{IRQ15}$	L18	$\overline{CS3}$
J22	A30	L19	V_{DDH}
K2	HA15	L20	A27
K3	HA21	L21	A25
K4	HA16	L22	A22
K5	$\overline{PWE3/PSDDQM3/PBS3}$	M2	HD28
K6	$\overline{PWE1/PSDDQM1/PBS1}$	M3	HD31
K7	$\overline{POE/PSDRAS/PGPL2}$	M4	V_{DDH}
K8	$\overline{IRQ2/BADDR30}$	M5	GND
K9	Reserved	M6	GND
K10	GND	M7	V_{DDH}
K11	GND	M8	V_{DD}
K12	GND	M9	V_{DDH}
K13	GND	M10	GND
K14	CLKOUT	M14	GND
M15	V_{DDH}	P12	V_{CCSYN}
M16	\overline{HBRST}	P13	GND
M17	V_{DDH}	P14	GND
M18	V_{DDH}	P15	\overline{TA}
M19	GND	P16	\overline{BR}
M20	V_{DDH}	P17	\overline{TEA}

Table 1. MSC8126 Signal Listing by Ball Designator (continued)

Des.	Signal Name	Des.	Signal Name
M21	A24	P18	$\overline{\text{PSDVAL}}$
M22	A21	P19	DP0/DREQ1/EXT_BR2
N2	HD26	P20	V _{DDH}
N3	HD30	P21	GND
N4	HD29	P22	A19
N5	HD24	R2	HD18
N6	$\overline{\text{PWE2/PSDDQM2/PBS2}}$	R3	V _{DDH}
N7	V _{DDH}	R4	GND
N8	$\overline{\text{HWBS0/HDBS0/HWBE0/HDBE0}}$	R5	HD22
N9	$\overline{\text{HBCS}}$	R6	$\overline{\text{HWBS6/HDBS6/HWBE6/HDBE6/PWE6/PSDDQM6/PBS6}}$
N10	GND	R7	$\overline{\text{HWBS4/HDBS4/HWBE4/HDBE4/PWE4/PSDDQM4/PBS4}}$
N14	GND	R8	TSZ1
N15	$\overline{\text{HRDS/HRW/HRDE}}$	R9	TSZ3
N16	$\overline{\text{BG}}$	R10	$\overline{\text{IRQ1/GBL}}$
N17	$\overline{\text{HCS}}$	R11	V _{DD}
N18	$\overline{\text{CS0}}$	R12	V _{DD}
N19	$\overline{\text{PSDWE/PGPL1}}$	R13	V _{DD}
N20	GPIO26/TDM0RDAT	R14	TT0/HA7
N21	A23	R15	$\overline{\text{IRQ7/DP7/DREQ4}}$
N22	A20	R16	$\overline{\text{IRQ6/DP6/DREQ3}}$
P2	HD20	R17	$\overline{\text{IRQ3/DP3/DREQ2/EXT_BR3}}$
P3	HD27	R18	$\overline{\text{TS}}$
P4	HD25	R19	$\overline{\text{IRQ2/DP2/DACK2/EXT_DBG2}}$
P5	HD23	R20	A17
P6	$\overline{\text{HWBS3/HDBS3/HWBE3/HDBE3}}$	R21	A18
P7	$\overline{\text{HWBS2/HDBS2/HWBE2/HDBE2}}$	R22	A16
P8	$\overline{\text{HWBS1/HDBS1/HWBE1/HDBE1}}$	T2	HD17
P9	HCLKIN	T3	HD21
P10	GND	T4	HD1/DSISYNC
P11	GND _{SYN}	T5	HD0/SWTE
T6	$\overline{\text{HWBS7/HDBS7/HWBE7/HDBE7/PWE7/PSDDQM7/PBS7}}$	U21	A12
T7	$\overline{\text{HWBS5/HDBS5/HWBE5/HDBE5/PWE5/PSDDQM5/PBS5}}$	U22	A13
T8	TSZ0	V2	HD3/MODCK1
T9	TSZ2	V3	V _{DDH}
T10	$\overline{\text{TBST}}$	V4	GND
T11	V _{DD}	V5	D0
T12	D16	V6	D1
T13	TT1	V7	D4
T14	D21	V8	D5

Table 1. MSC8126 Signal Listing by Ball Designator (continued)

Des.	Signal Name	Des.	Signal Name
T15	D23	V9	D7
T16	$\overline{\text{IRQ5/DP5/DACK4/EXT_BG3}}$	V10	D10
T17	$\overline{\text{IRQ4/DP4/DACK3/EXT_DBG3}}$	V11	D12
T18	$\overline{\text{IRQ1/DP1/DACK1/EXT_BG2}}$	V12	D13
T19	D30	V13	D18
T20	GND	V14	D20
T21	A15	V15	GND
T22	A14	V16	D24
U2	HD16	V17	D27
U3	HD19	V18	D29
U4	HD2/DSI64	V19	A8
U5	D2	V20	A9
U6	D3	V21	A10
U7	D6	V22	A11
U8	D8	W2	HD6
U9	D9	W3	HD5/CNFGS
U10	D11	W4	HD4/MODCK2
U11	D14	W5	GND
U12	D15	W6	GND
U13	D17	W7	V _{DDH}
U14	D19	W8	V _{DDH}
U15	D22	W9	GND
U16	D25	W10	HDST1/HA10
U17	D26	W11	HDST0/HA9
U18	D28	W12	V _{DDH}
U19	D31	W13	GND
U20	V _{DDH}	W14	HD40/D40/ETHRXD0
W15	V _{DDH}	AA9	V _{DDH}
W16	HD33/D33/reserved	AA10	HD54/D54/ETHTX_EN
W17	V _{DDH}	AA11	HD52/D52
W18	HD32/D32/reserved	AA12	V _{DDH}
W19	GND	AA13	GND
W20	GND	AA14	V _{DDH}
W21	A7	AA15	HD46/D46/ETHXT0
W22	A6	AA16	GND
Y2	HD7	AA17	HD42/D42/ETHRXD2/reserved
Y3	HD15	AA18	HD38/D38/reserved
Y4	V _{DDH}	AA19	HD35/D35/reserved
Y5	HD9	AA20	A0

Table 1. MSC8126 Signal Listing by Ball Designator (continued)

Des.	Signal Name	Des.	Signal Name
Y6	V _{DD}	AA21	A2
Y7	HD60/D60/ETHCOL/reserved	AA22	A3
Y8	HD58/D58/ETHMDC	AB2	GND
Y9	GND	AB3	HD13
Y10	V _{DDH}	AB4	HD11
Y11	HD51/D51	AB5	HD8
Y12	GND	AB6	HD62/D62
Y13	V _{DDH}	AB7	HD61/D61
Y14	HD43/D43/ETHRXD3/reserved	AB8	HD57/D57/ETHRX_ER
Y15	GND	AB9	HD56/D56/ETHRX_DV/ETHCRS_DV
Y16	V _{DDH}	AB10	HD55/D55/ETHTX_ER/reserved
Y17	GND	AB11	HD53/D53
Y18	HD37/D37/reserved	AB12	HD50/D50
Y19	HD34/D34/reserved	AB13	HD49/D49/ETHTXD3/reserved
Y20	V _{DDH}	AB14	HD48/D48/ETHTXD2/reserved
Y21	A4	AB15	HD47/D47/ETHTXD1
Y22	A5	AB16	HD45/D45
AA2	V _{DD}	AB17	HD44/D44
AA3	HD14	AB18	HD41/D41/ETHRXD1
AA4	HD12	AB19	HD39/D39/reserved
AA5	HD10	AB20	HD36/D36/reserved
AA6	HD63/D63	AB21	A1
AA7	HD59/D59/ETHMDIO	AB22	V _{DD}
AA8	GND		

2 Electrical Characteristics

This document contains detailed information on power considerations, DC/AC electrical characteristics, and AC timing specifications. For additional information, see the *MSC8126 Reference Manual*.

2.1 Maximum Ratings

CAUTION

This device contains circuitry protecting against damage due to high static voltage or electrical fields; however, normal precautions should be taken to avoid exceeding maximum voltage ratings. Reliability is enhanced if unused inputs are tied to an appropriate logic voltage level (for example, either GND or V_{DD}).

In calculating timing requirements, adding a maximum value of one specification to a minimum value of another specification does not yield a reasonable sum. A maximum specification is calculated using a worst case variation of process parameter values in one direction. The minimum specification is calculated using the worst case for the same parameters in the opposite direction. Therefore, a “maximum” value for a specification never occurs in the same device with a “minimum” value for another specification; adding a maximum to a minimum represents a condition that can never exist.

Table 2 describes the maximum electrical ratings for the MSC8126.

Table 2. Absolute Maximum Ratings

Rating	Symbol	Value	Unit
Core and PLL supply voltage	V_{DD}	-0.2 to 1.6	V
I/O supply voltage	V_{DDH}	-0.2 to 4.0	V
Input voltage	V_{IN}	-0.2 to 4.0	V
Maximum operating temperature:	T_J		
• 400 MHz		105	°C
• 500 MHz		90	°C
Minimum operating temperature	T_J		
• 400 MHz		-40	°C
• 500 MHz		0	°C
Storage temperature range	T_{STG}	-55 to +150	°C
Notes: <ol style="list-style-type: none"> Functional operating conditions are given in Table 3. Absolute maximum ratings are stress ratings only, and functional operation at the maximum is not guaranteed. Stress beyond the listed limits may affect device reliability or cause permanent damage. Section 3.5, Thermal Considerations includes a formula for computing the chip junction temperature (T_J). 			

2.2 Recommended Operating Conditions

Table 3 lists recommended operating conditions. Proper device operation outside of these conditions is not guaranteed.

Table 3. Recommended Operating Conditions

Rating	Symbol	Value	Unit
Core and PLL supply voltage: • Standard — 400 MHz — 500 MHz • Reduced (300 and 400 MHz)	V_{DD} V_{CCSYN}	1.14 to 1.26 1.16 to 1.24 1.07 to 1.13	V V V
I/O supply voltage	V_{DDH}	3.135 to 3.465	V
Input voltage	V_{IN}	-0.2 to $V_{DDH}+0.2$	V
Operating temperature range: • Standard • Extended	T_J T_J	0 to 90 -40 to 105	°C °C

2.3 Thermal Characteristics

Table 4 describes thermal characteristics of the MSC8126 for the FC-PBGA packages.

Table 4. Thermal Characteristics for the MSC8126

Characteristic	Symbol	FC-PBGA 20 × 20 mm ⁵		Unit
		Natural Convection	200 ft/min (1 m/s) airflow	
Junction-to-ambient ^{1, 2}	$R_{\theta JA}$	26	21	°C/W
Junction-to-ambient, four-layer board ^{1, 3}	$R_{\theta JA}$	19	15	°C/W
Junction-to-board (bottom) ⁴	$R_{\theta JB}$	9		°C/W
Junction-to-case ⁵	$R_{\theta JC}$	0.9		°C/W
Junction-to-package-top ⁶	Ψ_{JT}	1		°C/W
Notes: <ol style="list-style-type: none"> Junction temperature is a function of die size, on-chip power dissipation, package thermal resistance, mounting site (board) temperature, ambient temperature, air flow, power dissipation of other components on the board, and board thermal resistance. Per SEMI G38-87 and JEDEC JESD51-2 with the single layer board horizontal. Per JEDEC JESD51-6 with the board horizontal. Thermal resistance between the die and the printed circuit board per JEDEC JESD 51-8. Board temperature is measured on the top surface of the board near the package. Thermal resistance between the die and the case top surface as measured by the cold plate method (MIL SPEC-883 Method 1012.1). Thermal characterization parameter indicating the temperature difference between package top and the junction temperature per JEDEC JESD51-2. 				

Section 3.5, *Thermal Considerations* provides a detailed explanation of these characteristics.

2.4 DC Electrical Characteristics

This section describes the DC electrical characteristics for the MSC8126. The measurements in **Table 5** assume the following system conditions:

- $T_A = 25\text{ }^\circ\text{C}$
- $V_{DD} =$
 - 400 MHz = 1.14–1.26 V_{DC}
 - 500 MHz = 1.16–1.24 V_{DC}
- $V_{DDH} = 3.3\text{ V} \pm 5\% V_{DC}$
- $GND = 0\text{ }V_{DC}$

Note: The leakage current is measured for nominal V_{DDH} and V_{DD} .

Table 5. DC Electrical Characteristics

Characteristic	Symbol	Min	Typical	Max	Unit
Input high voltage ¹ , all inputs except CLKIN	V_{IH}	2.0	—	3.465	V
Input low voltage ¹	V_{IL}	GND	0	0.8	V
CLKIN input high voltage	V_{IHC}	2.4	3.0	3.465	V
CLKIN input low voltage	V_{ILC}	GND	0	0.8	V
Input leakage current, $V_{IN} = V_{DDH}$	I_{IN}	-1.0	0.09	1	μA
Tri-state (high impedance off state) leakage current, $V_{IN} = V_{DDH}$	I_{OZ}	-1.0	0.09	1	μA
Signal low input current, $V_{IL} = 0.8\text{ V}^2$	I_L	-1.0	0.09	1	μA
Signal high input current, $V_{IH} = 2.0\text{ V}^2$	I_H	-1.0	0.09	1	μA
Output high voltage, $I_{OH} = -2\text{ mA}$, except open drain pins	V_{OH}	2.0	3.0	—	V
Output low voltage, $I_{OL} = 3.2\text{ mA}$	V_{OL}	—	0	0.4	V
V_{CCSYN} PLL supply current	I_{VCCSYN}	—	2	4	mA
Internal supply current:					
• Wait mode	I_{DDW}	—	375 ³	—	mA
• Stop mode	I_{DDS}	—	290 ³	—	mA
Typical power 400 MHz at 1.2 V ⁴	P	—	1.15	—	W
Notes: <ol style="list-style-type: none"> 1. See Figure 5 for undershoot and overshoot voltages. 2. Not tested. Guaranteed by design. 3. Measured for 1.2 V core at 25°C junction temperature. 4. The typical power values were measured using an EFR code with the device running at a junction temperature of 25°C. No peripherals were enabled and the ICache was not enabled. The source code was optimized to use all the ALUs and AGUs and all four cores. It was created using CodeWarrior® 2.5. These values are provided as examples only. Power consumption is application dependent and varies widely. To assure proper board design with regard to thermal dissipation and maintaining proper operating temperatures, evaluate power consumption for your application and use the design guidelines in Chapter 4 of this document and in <i>MSC8102, MSC8122, and MSC8126 Thermal Management Design Guidelines (AN2601)</i>. 					

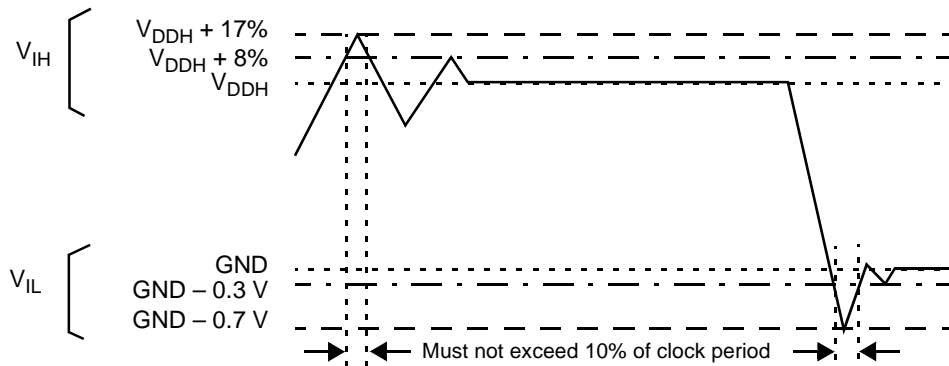

Figure 5. Overshoot/Undershoot Voltage for V_{IH} and V_{IL}

2.5 AC Timings

The following sections include illustrations and tables of clock diagrams, signals, and parallel I/O outputs and inputs. When systems such as DSP farms are developed using the DSI, use a device loading of 4 pF per pin. AC timings are based on a 20 pF load, except where noted otherwise, and a 50 Ω transmission line. For loads smaller than 20 pF, subtract 0.06 ns per pF down to 10 pF load. For loads larger than 20 pF, add 0.06 ns for SIU/Ethernet/DSI delay and 0.07 ns for GPIO/TDM/timer delay. When calculating overall loading, also consider additional RC delay.

2.5.1 Output Buffer Impedances

Table 6. Output Buffer Impedances

Output Buffers	Typical Impedance (Ω)
System bus	50
Memory controller	50
Parallel I/O	50

Note: These are typical values at 65°C. The impedance may vary by $\pm 25\%$ depending on device process and operating temperature.

2.5.2 Start-Up Timing

Starting the device requires coordination among several input sequences including clocking, reset, and power. **Section 2.5.3** describes the clocking characteristics. **Section 2.5.4** describes the reset and power-up characteristics. You must use the following guidelines when starting up an MSC8126 device:

- $\overline{\text{PORESET}}$ and $\overline{\text{TRST}}$ must be asserted externally for the duration of the power-up sequence. See **Table 11** for timing.
- If possible, bring up the V_{DD} and V_{DDH} levels together. For designs with separate power supplies, bring up the V_{DD} levels and then the V_{DDH} levels (see **Figure 7**).
- CLKIN should start toggling at least 16 cycles (starting after V_{DDH} reaches its nominal level) before $\overline{\text{PORESET}}$ deassertion to guarantee correct device operation (see **Figure 6** and **Figure 7**).
- CLKIN must not be pulled high during V_{DDH} power-up. CLKIN can toggle during this period.

Note: See **Section 3.1** for start-up sequencing recommendations and **Section 3.2** for power supply design recommendations.

The following figures show acceptable start-up sequence examples. **Figure 6** shows a sequence in which V_{DD} and V_{DDH} are raised together. **Figure 7** shows a sequence in which V_{DDH} is raised after V_{DD} and CLKIN begins to toggle as V_{DDH} rises.

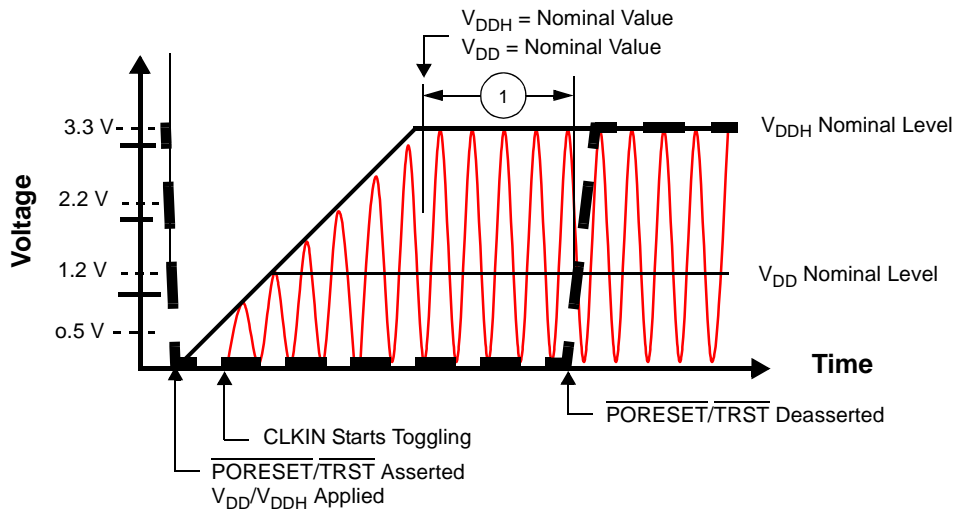

Figure 6. Start-Up Sequence: V_{DD} and V_{DDH} Raised Together

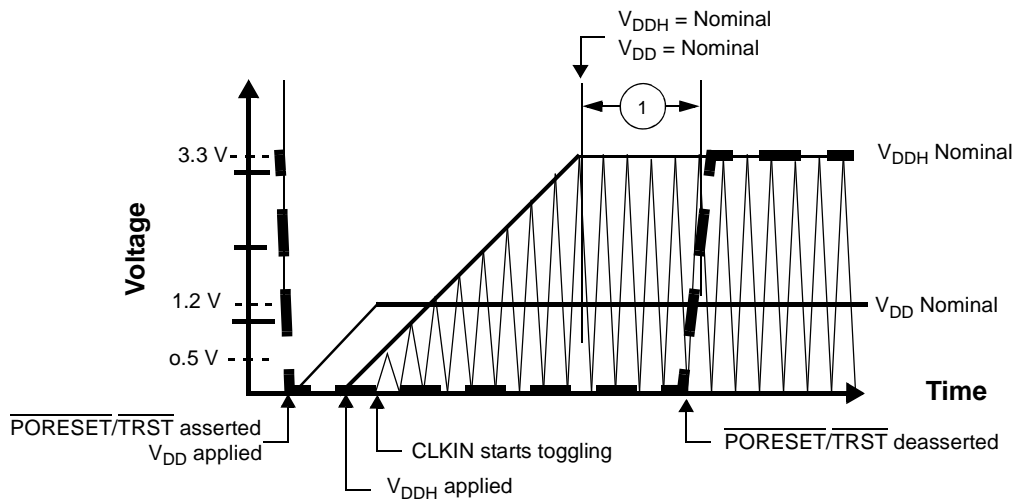

Figure 7. Start-Up Sequence: V_{DD} Raised Before V_{DDH} with $CLKIN$ Started with V_{DDH}

In all cases, the power-up sequence must follow the guidelines shown in **Figure 8**.

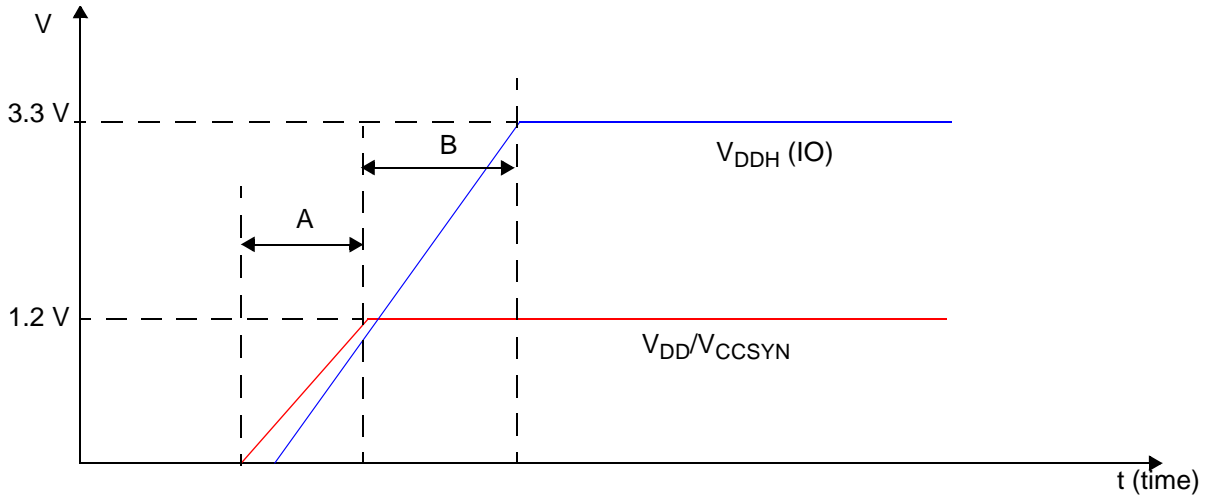

Figure 8. Power-Up Sequence for V_{DDH} and V_{DD}/V_{CCSYN}

The following rules apply:

1. During time interval A, V_{DDH} should always be equal to or less than the V_{DD}/V_{CCSYN} voltage level. The duration of interval A should be kept below 10 ms.
2. The duration of timing interval B should be kept as small as possible and less than 10 ms.

2.5.3 Clock and Timing Signals

The following sections include a description of clock signal characteristics. **Table 7** shows the maximum frequency values for internal (Core, Reference, Bus, and DSI) and external (CLKIN and CLKOUT) clocks. The user must ensure that maximum frequency values are not exceeded.

Table 7. Maximum Frequencies

Characteristic	Maximum in MHz
Core frequency	400/500
Reference frequency (REFCLK)	133/166
Internal bus frequency (BLCK)	133/166
DSI clock frequency (HCLKIN)	$HCLKIN \leq (\min\{100 \text{ MHz, CLKOUT}\})$
External clock frequency (CLKIN or CLKOUT)	133/166

Table 8. Clock Frequencies

Characteristics	Symbol	400 MHz Device		500 MHz Device	
		Min	Max	Min	Max
CLKIN frequency	F_{CLKIN}	20	133.3	20	166.7
BCLK frequency	F_{BCLK}	40	133.3	40	166.7
Reference clock (REFCLK) frequency	F_{REFCLK}	40	133.3	40	166.7
Output clock (CLKOUT) frequency	F_{CLKOUT}	40	133.3	40	166.7
SC140 core clock frequency	F_{CORE}	200	400	200	500
Note: The rise and fall time of external clocks should be 5 ns maximum					

Table 9. System Clock Parameters

Characteristic	Min	Max	Unit
Phase jitter between BCLK and CLKIN	—	0.3	ns
CLKIN frequency	20	see Table 8	MHz
CLKIN slope	—	3	ns
PLL input clock (after predivider)	20	100	MHz
PLL output frequency (VCO output)	800		MHz
• 400 MHz core		1600	MHz
• 500 MHz core		2000	MHz
CLKOUT frequency jitter ¹	—	200	ps
CLKOUT phase jitter ¹ with CLKIN phase jitter of ± 100 ps	—	500	ps
Notes:			
1. Peak-to-peak.			
2. Not tested. Guaranteed by design.			

2.5.4 Reset Timing

The MSC8126 has several inputs to the reset logic:

- Power-on reset ($\overline{\text{PORESET}}$)
- External hard reset ($\overline{\text{HRESET}}$)
- External soft reset ($\overline{\text{SRESET}}$)
- Software watchdog reset
- Bus monitor reset
- Host reset command through JTAG

All MSC8126 reset sources are fed into the reset controller, which takes different actions depending on the source of the reset. The reset status register indicates the most recent sources to cause a reset. **Table 10** describes the reset sources.

Table 10. Reset Sources

Name	Direction	Description
Power-on reset ($\overline{\text{PORESET}}$)	Input	Initiates the power-on reset flow that resets the MSC8126 and configures various attributes of the MSC8126. On $\overline{\text{PORESET}}$, the entire MSC8126 device is reset. SPLL states is reset, $\overline{\text{HRESET}}$ and $\overline{\text{SRESET}}$ are driven, the SC140 extended cores are reset, and system configuration is sampled. The clock mode (MODCK bits), reset configuration mode, boot mode, Chip ID, and use of either a DSI 64 bits port or a System Bus 64 bits port are configured only when $\overline{\text{PORESET}}$ is asserted.
External hard reset ($\overline{\text{HRESET}}$)	Input/ Output	Initiates the hard reset flow that configures various attributes of the MSC8126. While $\overline{\text{HRESET}}$ is asserted, $\overline{\text{SRESET}}$ is also asserted. $\overline{\text{HRESET}}$ is an open-drain pin. Upon hard reset, $\overline{\text{HRESET}}$ and $\overline{\text{SRESET}}$ are driven, the SC140 extended cores are reset, and system configuration is sampled. The most configurable features are reconfigured. These features are defined in the 32-bit hard reset configuration word described in <i>Hard Reset Configuration Word</i> section of the <i>Reset</i> chapter in the <i>MSC8126 Reference Manual</i> .
External soft reset ($\overline{\text{SRESET}}$)	Input/ Output	Initiates the soft reset flow. The MSC8126 detects an external assertion of $\overline{\text{SRESET}}$ only if it occurs while the MSC8126 is not asserting reset. $\overline{\text{SRESET}}$ is an open-drain pin. Upon soft reset, $\overline{\text{SRESET}}$ is driven, the SC140 extended cores are reset, and system configuration is maintained.
Software watchdog reset	Internal	When the MSC8126 watchdog count reaches zero, a software watchdog reset is signalled. The enabled software watchdog event then generates an internal hard reset sequence.
Bus monitor reset	Internal	When the MSC8126 bus monitor count reaches zero, a bus monitor hard reset is asserted. The enabled bus monitor event then generates an internal hard reset sequence.
Host reset command through the TAP	Internal	When a host reset command is written through the Test Access Port (TAP), the TAP logic asserts the soft reset signal and an internal soft reset sequence is generated.

Table 11 summarizes the reset actions that occur as a result of the different reset sources.

Table 11. Reset Actions for Each Reset Source

Reset Action/Reset Source	Power-On Reset (PORESET)	Hard Reset (HRESET)	Soft Reset (SRESET)	
	External only	External or Internal (Software Watchdog or Bus Monitor)	External	JTAG Command: EXTEST, CLAMP, or HIGHZ
Configuration pins sampled (Refer to Section 2.5.4.1 for details).	Yes	No	No	No
SPLL state reset	Yes	No	No	No
System reset configuration write through the DSI	Yes	No	No	No
System reset configuration write through the system bus	Yes	Yes	No	No
HRESET driven	Yes	Yes	No	No
SIU registers reset	Yes	Yes	No	No
IPBus modules reset (TDM, UART, Timers, DSI, IPBus master, GIC, HS, and GPIO)	Yes	Yes	Yes	Yes
SRESET driven	Yes	Yes	Yes	Depends on command
SC140 extended cores reset	Yes	Yes	Yes	Yes
MQBS reset	Yes	Yes	Yes	Yes

2.5.4.1 Power-On Reset ($\overline{\text{PORESET}}$) Pin

Asserting $\overline{\text{PORESET}}$ initiates the power-on reset flow. $\overline{\text{PORESET}}$ must be asserted externally for at least 16 CLKIN cycles after V_{DD} and V_{DDH} are both at their nominal levels.

2.5.4.2 Reset Configuration

The MSC8126 has two mechanisms for writing the reset configuration:

- Through the direct slave interface (DSI)
- Through the system bus. When the reset configuration is written through the system bus, the MSC8126 acts as a configuration master or a configuration slave. If configuration slave is selected, but no special configuration word is written, a default configuration word is applied.

Fourteen signal levels (see **Chapter 1** for signal description details) are sampled on $\overline{\text{PORESET}}$ deassertion to define the Reset Configuration Mode and boot and operating conditions:

- $\overline{\text{RSTCONF}}$
- CNFGS
- DSISYNC
- DSI64
- CHIP_ID[0–3]
- BM[0–2]
- SWTE
- MODCK[1–2]

2.5.4.3 Reset Timing Tables

Table 12 and Figure 9 describe the reset timing for a reset configuration write through the direct slave interface (DSI) or through the system bus.

Table 12. Timing for a Reset Configuration Write through the DSI or System Bus

No.	Characteristics	Expression	Min	Max	Unit
1	Required external $\overline{\text{PORESET}}$ duration minimum <ul style="list-style-type: none"> CLKIN = 20 MHz CLKIN = 133 MHz (400 MHz core) CLKIN = 166 MHz (500 MHz core) 	$16/\text{CLKIN}$	800 120 96	800 — —	ns ns ns
2	Delay from deassertion of external $\overline{\text{PORESET}}$ to deassertion of internal $\overline{\text{PORESET}}$ <ul style="list-style-type: none"> CLKIN = 20 MHz to 166 MHz 	$1024/\text{CLKIN}$	6.17	51.2	μs
3	Delay from de-assertion of internal $\overline{\text{PORESET}}$ to SPLL lock <ul style="list-style-type: none"> CLKIN = 20 MHz (RDF = 1) CLKIN = 133 MHz (RDF = 2) (400 MHz core) CLKIN = 166 MHz (RDF = 2) (500 MHz core) 	$6400/(\text{CLKIN}/\text{RDF})$ (PLL reference clock-division factor)	320 96 77	320 96 77	μs μs μs
5	Delay from SPLL to $\overline{\text{HRESET}}$ deassertion <ul style="list-style-type: none"> REFCLK = 40 MHz to 166 MHz 	$512/\text{REFCLK}$	3.08	12.8	μs
6	Delay from SPLL lock to $\overline{\text{SRESET}}$ deassertion <ul style="list-style-type: none"> REFCLK = 40 MHz to 166 MHz 	$515/\text{REFCLK}$	3.10	12.88	μs
7	Setup time from assertion of $\overline{\text{RSTCONF}}$, CNFGS, DSISYNC, DSI64, CHIP_ID[0–3], BM[0–2], SWTE, and MODCK[1–2] before deassertion of $\overline{\text{PORESET}}$		3	—	ns
8	Hold time from deassertion of $\overline{\text{PORESET}}$ to deassertion of $\overline{\text{RSTCONF}}$, CNFGS, DSISYNC, DSI64, CHIP_ID[0–3], BM[0–2], SWTE, and MODCK[1–2]		5	—	ns

Note: Timings are not tested, but are guaranteed by design.

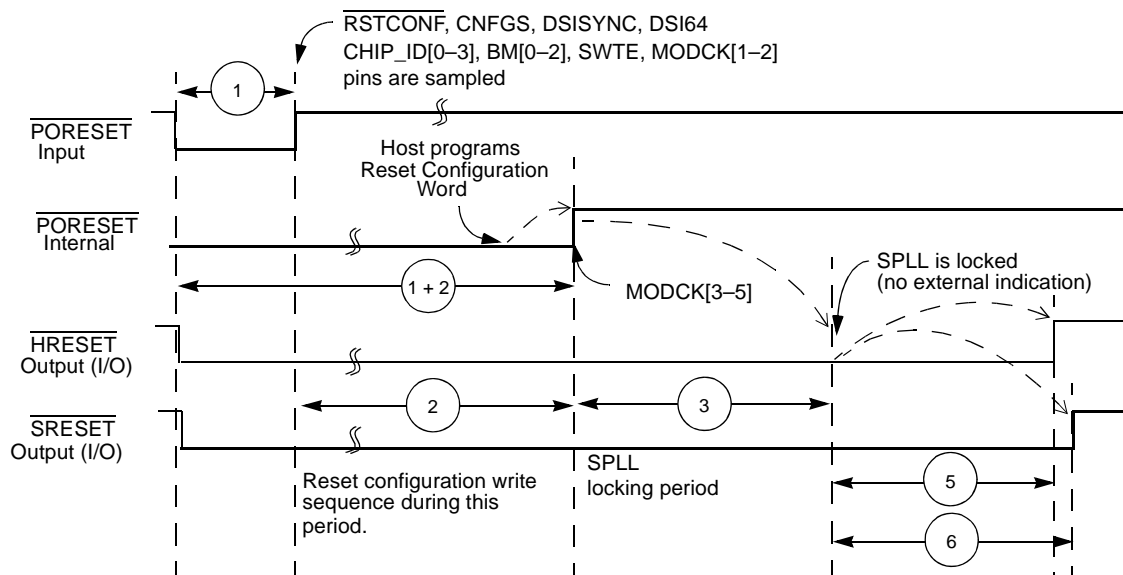

Figure 9. Timing Diagram for a Reset Configuration Write

2.5.5 System Bus Access Timing

2.5.5.1 Core Data Transfers

Generally, all MSC8126 bus and system output signals are driven from the rising edge of the reference clock (REFCLK). The REFCLK is the CLKIN signal. Memory controller signals, however, trigger on four points within a REFCLK cycle. Each cycle is divided by four internal ticks: T1, T2, T3, and T4. T1 always occurs at the rising edge of REFCLK (and T3 at the falling edge), but the spacing of T2 and T4 depends on the PLL clock ratio selected, as **Table 13** shows.

Table 13. Tick Spacing for Memory Controller Signals

BCLK/SC140 clock	Tick Spacing (T1 Occurs at the Rising Edge of REFCLK)		
	T2	T3	T4
1:4, 1:6, 1:8, 1:10	1/4 REFCLK	1/2 REFCLK	3/4 REFCLK
1:3	1/6 REFCLK	1/2 REFCLK	4/6 REFCLK
1:5	2/10 REFCLK	1/2 REFCLK	7/10 REFCLK

Figure 10 is a graphical representation of **Table 13**.

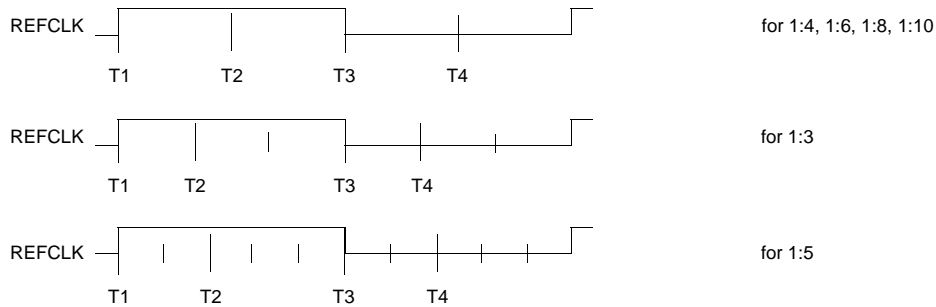

Figure 10. Internal Tick Spacing for Memory Controller Signals

The UPM machine and GPCM machine outputs change on the internal tick selected by the memory controller configuration. The AC timing specifications are relative to the internal tick. SDRAM machine outputs change only on the REFCLK rising edge.

Table 14. AC Timing for SIU Inputs

No.	Characteristic	Value for Bus Speed in MHz			Units
		Ref = CLKIN		Ref = CLKOUT	
		133	166	133	
10	Hold time for all signals after the 50% level of the REFCLK rising edge	0.5	0.5	0.5	ns
11a	$\overline{\text{ARTRY}}/\overline{\text{ABB}}$ set-up time before the 50% level of the REFCLK rising edge	3.0	3.0	3.0	ns
11b	$\overline{\text{DBG}}/\overline{\text{DBB}}/\overline{\text{BG}}/\overline{\text{BR}}/\overline{\text{TC}}$ set-up time before the 50% level of the REFCLK rising edge	3.3	3.3	3.3	ns
11c	$\overline{\text{AACK}}$ set-up time before the 50% level of the REFCLK rising edge	2.9	2.9	2.9	ns
11d	$\overline{\text{TA}}/\overline{\text{TEA}}/\overline{\text{PSDVAL}}$ set-up time before the 50% level of the REFCLK rising edge • Data-pipeline mode • Non-pipeline mode	3.4	3.4	3.4	ns
		4.0	4.0	4.0	ns
12	Data bus set-up time before REFCLK rising edge in Normal mode • Data-pipeline mode • Non-pipeline mode	1.8	1.7	1.8	ns
		4.0	4.0	4.0	ns
13 ¹	Data bus set-up time before the 50% level of the REFCLK rising edge in ECC and PARITY modes • Data-pipeline mode • Non-pipeline mode	2.0	2.0	2.0	ns
		7.3	7.3	7.3	ns
14 ¹	DP set-up time before the 50% level of the REFCLK rising edge • Data-pipeline mode • Non-pipeline mode	2.0	2.0	2.0	ns
		6.1	6.1	6.1	ns
15a	$\overline{\text{TS}}$ and Address bus set-up time before the 50% level of the REFCLK rising edge • Extra cycle mode (SIUBCR[EXDD] = 0) • No extra cycle mode (SIUBCR[EXDD] = 1)	3.6	3.6	3.8	ns
		5.0	5.0	5.0	ns
15b	Address attributes: $\overline{\text{TT}}/\overline{\text{TBST}}/\overline{\text{TSZ}}/\overline{\text{GBL}}$ set-up time before the 50% level of the REFCLK rising edge • Extra cycle mode (SIUBCR[EXDD] = 0) • No extra cycle mode (SIUBCR[EXDD] = 1)	3.5	3.5	3.5	ns
		4.4	4.4	4.4	ns
16	PUPMWAIT signal set-up time before the 50% level of the REFCLK rising edge	3.7	3.7	3.7	ns
17	$\overline{\text{IRQx}}$ setup time before the 50% level; of the REFCLK rising edge ³	4.0	4.0	4.0	ns
18	$\overline{\text{IRQx}}$ minimum pulse width ³	$6.0 + T_{\text{REFCLK}}$	$6.0 + T_{\text{REFCLK}}$	$6.0 + T_{\text{REFCLK}}$	ns
Notes:					
1. Timings specifications 13 and 14 in non-pipeline mode are more restrictive than MSC8102 timings.					
2. Values are measured from the 50% TTL transition level relative to the 50% level of the REFCLK rising edge.					
3. Guaranteed by design					

Table 15. AC Timing for SIU Outputs

No.	Characteristic	Value for Bus Speed in MHz			Units
		Ref = CLKIN		Ref = CLKOUT	
		133	166	133	
30 ²	Minimum delay from the 50% level of the REFCLK for all signals	0.8	0.8	1.0	ns

Table 15. AC Timing for SIU Outputs (continued)

No.	Characteristic	Value for Bus Speed in MHz			Units
		Ref = CLKIN		Ref = CLKOUT	
		133	166	133	
31	PSDVAL/TEA/TA max delay from the 50% level of the REFCLK rising edge	4.9	4.9	5.8	ns
32a	Address bus max delay from the 50% level of the REFCLK rising edge <ul style="list-style-type: none"> Multi-master mode (SIUBCR[EBM] = 1) Single-master mode (SIUBCR[EBM] = 0) 	5.5	5.5	6.4	ns
		4.2	3.9	5.1	ns
32b	Address attributes: TT[0–1]/TBST/TSZ/GBL max delay from the 50% level of the REFCLK rising edge	5.1	5.1	6.0	ns
32c	Address attributes: TT[2–4]/TC max delay from the 50% level of the REFCLK rising edge	5.7	5.7	6.6	ns
32d	BADDR max delay from the 50% level of the REFCLK rising edge	4.2	4.2	5.1	ns
33a	Data bus max delay from the 50% level of the REFCLK rising edge <ul style="list-style-type: none"> Data-pipeline mode Non-pipeline mode 	3.9	3.7	4.8	ns
		6.1	6.1	7.0	ns
33b	DP max delay from the 50% level of the REFCLK rising edge <ul style="list-style-type: none"> Data-pipeline mode Non-pipeline mode 	5.3	5.3	6.2	ns
		6.5	6.5	7.4	ns
34	Memory controller signals/ALE/ $\overline{\text{CS}}[0–4]$ max delay from the 50% level of the REFCLK rising edge	4.2	3.9	5.1	ns
35a	$\overline{\text{DBG}}/\overline{\text{BG}}/\overline{\text{BR}}/\overline{\text{DBB}}$ max delay from the 50% level of the REFCLK rising edge	4.7	4.7	5.6	ns
35b	$\overline{\text{AACK}}/\overline{\text{ABB}}/\overline{\text{TS}}/\overline{\text{CS}}[5–7]$ max delay from the 50% level of the REFCLK rising edge	4.5	4.5	5.4	ns
Notes:	<ol style="list-style-type: none"> Values are measured from the 50% level of the REFCLK rising edge to the 50% signal level and assume a 20 pF load except where otherwise specified. Except for specification 30, which is specified for a 10 pF load, all timings in this table are specified for a 20 pF load. Decreasing the load results in a timing decrease at the rate of 0.3 ns per 5 pF decrease in load. Increasing the load results in a timing increase at the rate of 0.15 ns per 5 pF increase in load. The maximum bus frequency depends on the mode: In 60x-compatible mode connected to another MSC8126 device, the frequency is determined by adding the input and output longest timing values, which results in the total delay for 20 pF output capacitance. You must also account for other influences that can affect timing, such as on-board clock skews, on-board noise delays, and so on. <ul style="list-style-type: none"> In single-master mode, the frequency depends on the timing of the devices connected to the MSC8126. To achieve maximum performance on the bus in single-master mode, disable the $\overline{\text{DBB}}$ signal by writing a 1 to the SIUMCR[BDD] bit. See the SIU chapter in the <i>MSC8122 Reference Manual</i> for details. 				

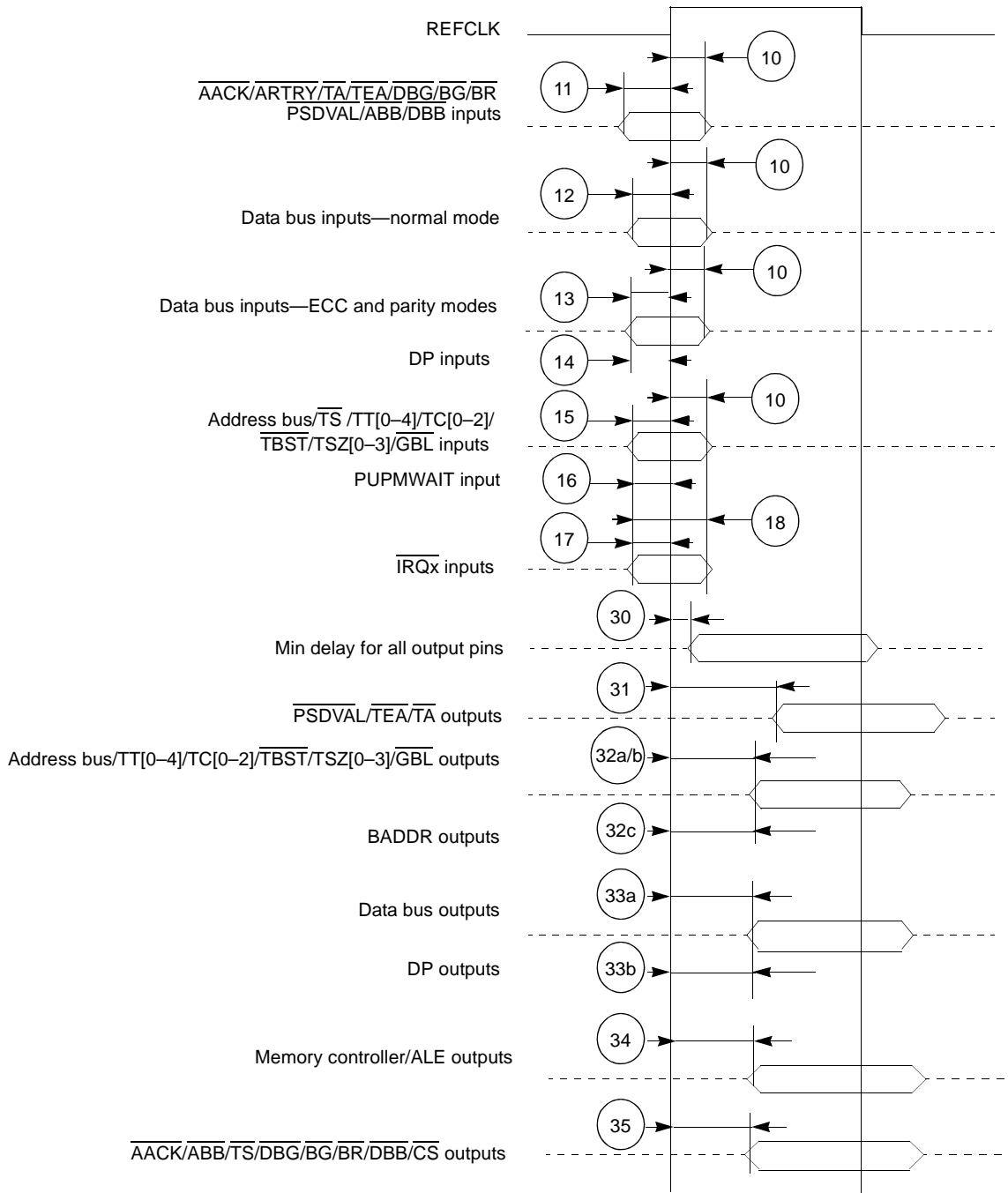

Figure 11. SIU Timing Diagram

2.5.5.2 CLKIN to CLKOUT Skew

Table 17 describes the CLKOUT-to-CLKIN skew timing.

Table 16. CLKOUT Skew

No.	Characteristic	Min ¹	Max ¹	Units
20	Rise-to-rise skew	0	0.85	ns
21	Fall-to-fall skew	-0.8	1.0	ns
22	CLKOUT phase high and low (1.2 V, 133 MHz)	2.8	—	ns
Notes:	1. A positive number indicates that CLKOUT precedes CLKIN, A negative number indicates that CLKOUT follows CLKIN. 2. Skews are measured in clock mode 29, with a CLKIN:CLKOUT ratio of 1:1. The same skew is valid for all clock modes. 3. CLKOUT skews are measured using a load of 10 pF. 4. CLKOUT skews and phase are not measured for 500/166 Mhz parts because these parts only use CLKIN mode.			

For designs that use the CLKOUT synchronization mode, use the skew values listed in Table 16 to adjust the rise-to-fall timing values specified for CLKIN synchronization. Figure 12 shows the relationship between the CLKOUT and CLKIN timings.

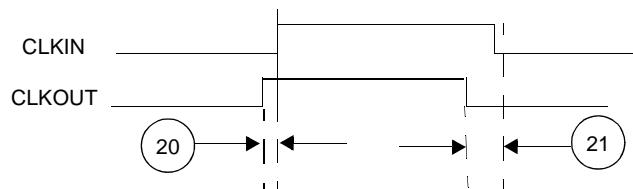

Figure 12. CLKOUT and CLKIN Signals.

2.5.5.3 DMA Data Transfers

Table 17 describes the DMA signal timing.

Table 17. DMA Signals

No.	Characteristic	Ref = CLKIN		Ref = CLKOUT (1.2 V only)		Units
		Min	Max	Min	Max	
37	DREQ set-up time before the 50% level of the falling edge of REFCLK	5.0	—	5.0	—	ns
38	DREQ hold time after the 50% level of the falling edge of REFCLK	0.5	—	0.5	—	ns
39	DONE set-up time before the 50% level of the rising edge of REFCLK	5.0	—	5.0	—	ns
40	DONE hold time after the 50% level of the rising edge of REFCLK	0.5	—	0.5	—	ns
41	DACK/DRACK/DONE delay after the 50% level of the REFCLK rising edge	0.5	7.5	0.5	8.4	ns

The DREQ signal is synchronized with REFCLK. To achieve fast response, a synchronized peripheral should assert DREQ according to the timings in Table 17. Figure 13 shows synchronous peripheral interaction.

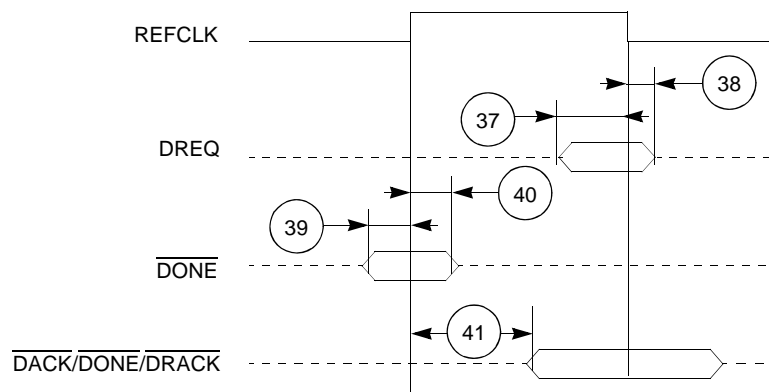

Figure 13. DMA Signals

2.5.6 DSI Timing

The timings in the following sections are based on a 20 pF capacitive load.

2.5.6.1 DSI Asynchronous Mode

Table 18. DSI Asynchronous Mode Timing

No.	Characteristics	Min	Max	Unit
100	Attributes ¹ set-up time before strobe (HWBS[n]) assertion	1.5	—	ns
101	Attributes ¹ hold time after data strobe deassertion	1.3	—	ns
102	Read/Write data strobe deassertion width: <ul style="list-style-type: none"> • DCR[HTAAD] = 1 <ul style="list-style-type: none"> — Consecutive access to the same DSI — Different device with DCR[HTADT] = 01 — Different device with DCR[HTADT] = 10 — Different device with DCR[HTADT] = 11 • DCR[HTAAD] = 0 	$1.8 + T_{REFCLK}$ $5 + T_{REFCLK}$ $5 + (1.5 \times T_{REFCLK})$ $5 + (2.5 \times T_{REFCLK})$ $1.8 + T_{REFCLK}$	—	ns ns ns ns ns
103	Read data strobe deassertion to output data high impedance	—	8.5	ns
104	Read data strobe assertion to output data active from high impedance	2.0	—	ns
105	Output data hold time after read data strobe deassertion	2.2	—	ns
106	Read/Write data strobe assertion to HTA active from high impedance	2.2	—	ns
107	Output data valid to HTA assertion	3.2	—	ns
108	Read/Write data strobe assertion to HTA valid ² <ul style="list-style-type: none"> • 1.1 V core • 1.2 V core 	— —	7.4 6.7	ns ns
109	Read/Write data strobe deassertion to output HTA high impedance. (DCR[HTAAD] = 0, HTA at end of access released at logic 0)	—	6.5	ns
110	Read/Write data strobe deassertion to output HTA deassertion. (DCR[HTAAD] = 1, HTA at end of access released at logic 1)	—	6.5	ns
111	Read/Write data strobe deassertion to output HTA high impedance. (DCR[HTAAD] = 1, HTA at end of access released at logic 1 <ul style="list-style-type: none"> • DCR[HTADT] = 01 • DCR[HTADT] = 10 • DCR[HTADT] = 11 	—	$5 + T_{REFCLK}$ $5 + (1.5 \times T_{REFCLK})$ $5 + (2.5 \times T_{REFCLK})$	ns ns ns
112	Read/Write data strobe assertion width	$1.8 + T_{REFCLK}$	—	ns
201	Host data input set-up time before write data strobe deassertion	1.0	—	ns
202	Host data input hold time after write data strobe deassertion <ul style="list-style-type: none"> • 1.1 V core • 1.2 V core 	1.7 1.5	— —	ns ns
Notes:	<ol style="list-style-type: none"> 1. <i>Attributes</i> refers to the following signals: HCS, HA[11–29], HCID[0–4], HDST, HRW, HRDS, and HWBSn. 2. This specification is tested in dual-strobe mode. Timing in single-strobe mode is guaranteed by design. 3. All values listed in this table are tested or guaranteed by design. 			

Figure 14 shows DSI asynchronous read signals timing.

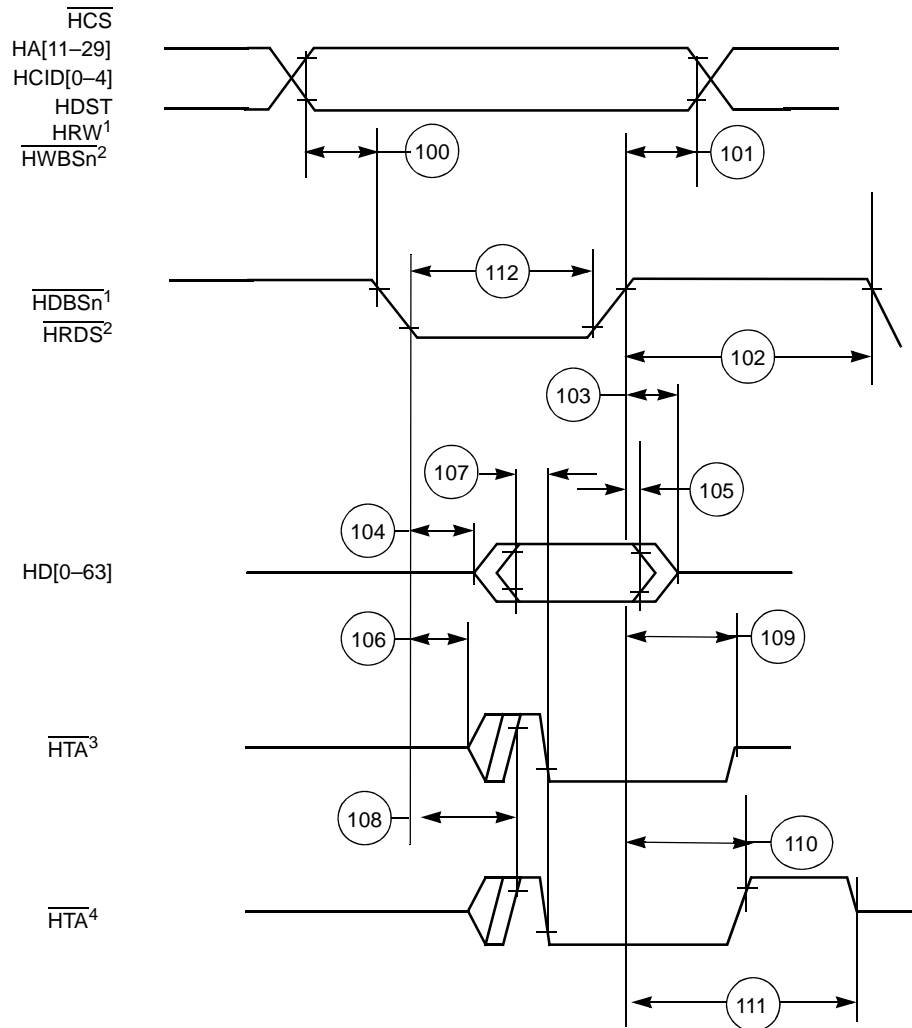

- Notes:**
1. Used for single-strobe mode access.
 2. Used for dual-strobe mode access.
 3. HTA released at logic 0 (DCR[HTAAD] = 0) at end of access; used with pull-down implementation.
 4. HTA released at logic 1 (DCR[HTAAD] = 1) at end of access; used with pull-up implementation.

Figure 14. Asynchronous Single- and Dual-Strobe Modes Read Timing Diagram

Figure 15 shows DSI asynchronous write signals timing.

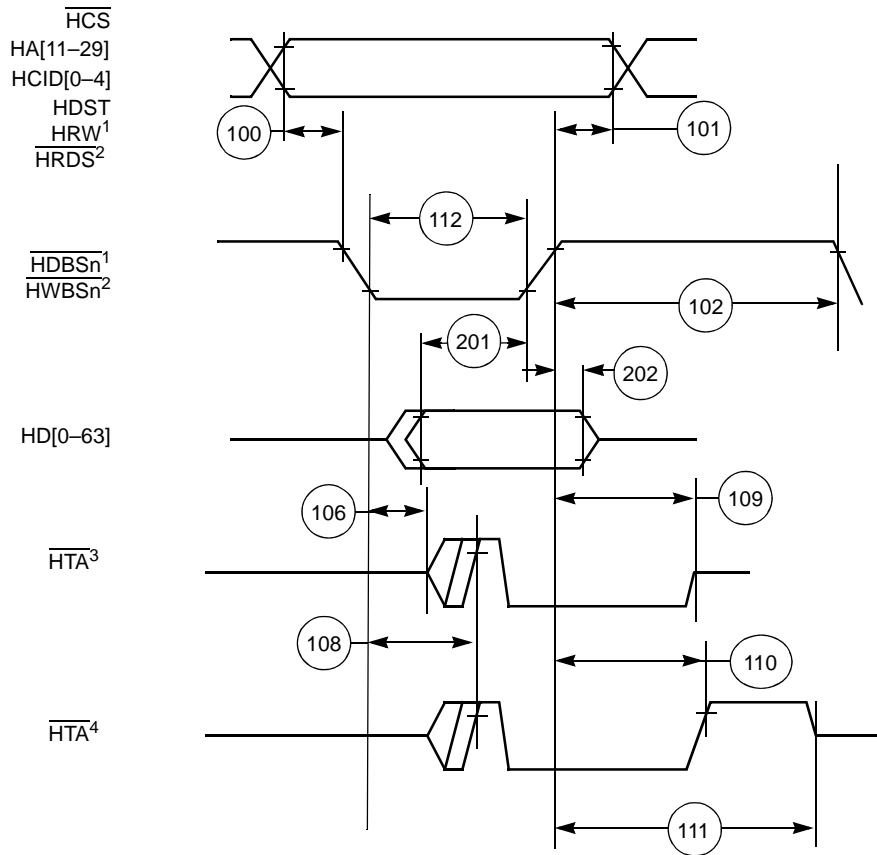

- Notes:**
1. Used for single-strobe mode access.
 2. Used for dual-strobe mode access.
 3. \overline{HTA} released at logic 0 (DCR[HTAAD] = 0) at end of access; used with pull-down implementation.
 4. \overline{HTA} released at logic 1 (DCR[HTAAD] = 1) at end of access; used with pull-up implementation.

Figure 15. Asynchronous Single- and Dual-Strobe Modes Write Timing Diagram

Figure 16 shows DSI asynchronous broadcast write signals timing.

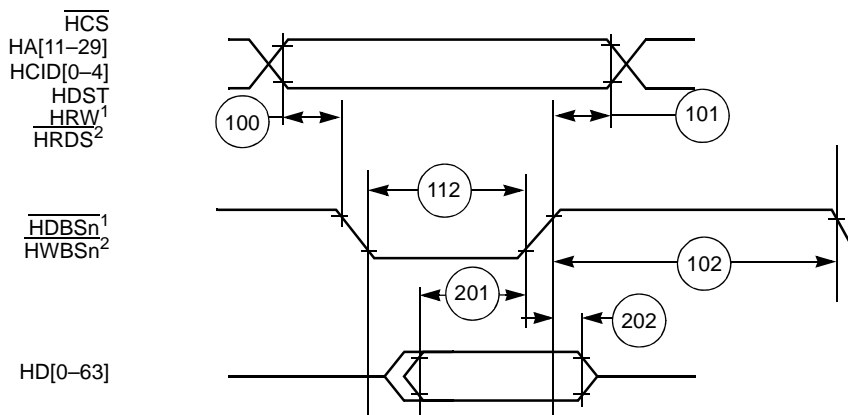

- Notes:**
1. Used for single-strobe mode access.
 2. Used for dual-strobe mode access.

Figure 16. Asynchronous Broadcast Write Timing Diagram

2.5.6.2 DSI Synchronous Mode

Table 19. DSI Inputs—Synchronous Mode

No.	Characteristic	Expression	Min	Max	Units
120	HCLKIN Cycle Time ^{1, 2}	HTC	10.0	55.6	ns
121	HCLKIN high Pulse Width	$(0.5 \pm 0.1) \times \text{HTC}$	4.0	33.3	ns
122	HCLKIN low Pulse Width	$(0.5 \pm 0.1) \times \text{HTC}$	4.0	33.3	ns
123	HA[11–29] inputs set-up time	—	1.2	—	ns
124	HD[0–63] inputs set-up time	—	0.4	—	ns
125	HCID[0–4] inputs set-up time	—	1.3	—	ns
126	All other inputs set-up time	—	1.2	—	ns
127	All inputs hold time	—	1.5	—	ns

Notes: 1. Values are based on a frequency range of 18–100 MHz.
2. Refer to Table 7 for HCLKIN frequency limits.

Table 20. DSI Outputs—Synchronous Mode

No.	Characteristic	Min	Max	Units
128	HCLKIN high to HD[0–63] output active	2.0	—	ns
129	HCLKIN high to HD[0–63] output valid	—	6.3	ns
130	HD[0–63] output hold time	1.7	—	ns
131	HCLKIN high to HD[0–63] output high impedance	—	7.6	ns
132	HCLKIN high to $\overline{\text{HTA}}$ output active	2.0	—	ns
133	HCLKIN high to $\overline{\text{HTA}}$ output valid	—	5.9	ns
134	$\overline{\text{HTA}}$ output hold time	1.7	—	ns
135	HCLKIN high to $\overline{\text{HTA}}$ high impedance	—	6.3	ns

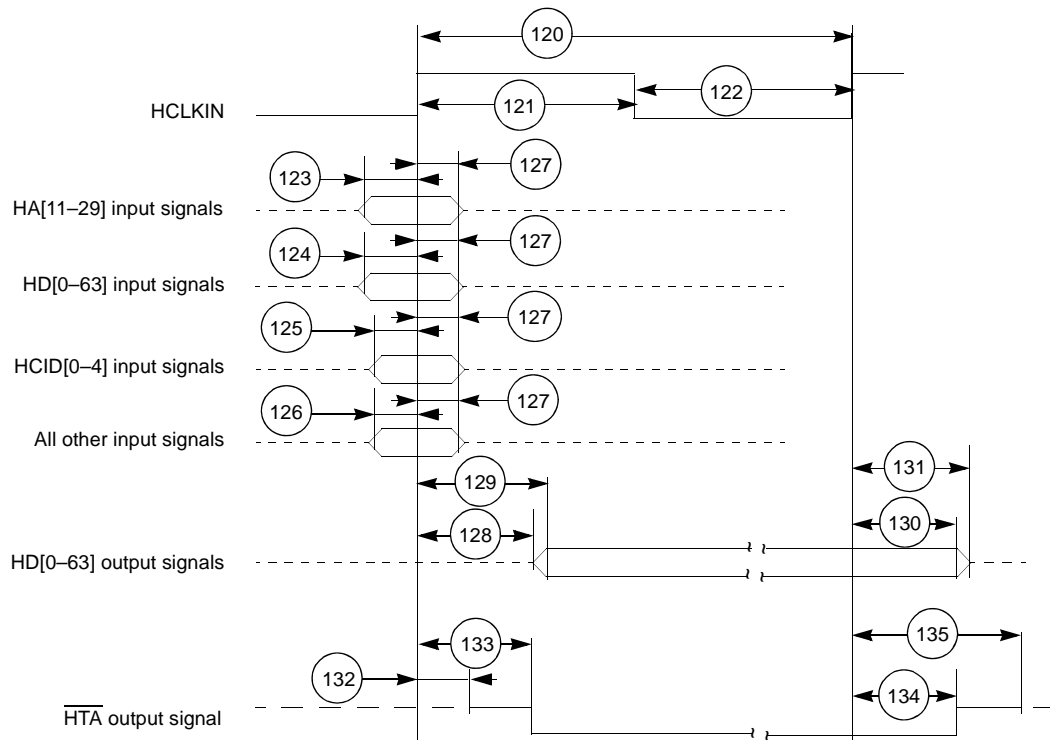

Figure 17. DSI Synchronous Mode Signals Timing Diagram

2.5.7 TDM Timing

Table 21. TDM Timing

No.	Characteristic	Expression	Ref = CLKIN		Units
			Min	Max	
300	TDMxRCLK/TDMxTCLK	TC^1	16	—	ns
301	TDMxRCLK/TDMxTCLK high pulse width	$(0.5 \pm 0.1) \times TC$	7	—	ns
302	TDMxRCLK/TDMxTCLK low pulse width	$(0.5 \pm 0.1) \times TC$	7	—	ns
303	TDM receive all input set-up time		1.3	—	ns
304	TDM receive all input hold time		1.0	—	ns
305	TDMxTCLK high to TDMxTDAT/TDMxRCLK output active ^{2,3}		2.8	—	ns
306	TDMxTCLK high to TDMxTDAT/TDMxRCLK output valid ^{2,3}		—	8.8	ns
307	All output hold time ⁵		2.5	—	ns
308	TDMxTCLK high to TDMxTDAT/TDMxRCLK output high impedance ^{2,3}		—	10.5	ns
309	TDMxTCLK high to TDMxTSYN output valid ²		—	8.5	ns
310	TDMxTSYN output hold time ⁵		2.5	—	ns

Notes:

1. Values are based on a a maximum frequency of 62.5 MHz. The TDM interface supports any frequency below 62.5 MHz.
2. Values are based on 20 pF capacitive load.
3. When configured as an output, TDMxRCLK acts as a second data link. See the *MSC8126 Reference Manual* for details.
4. CLKOUT synchronization is not supported for cores operating at above 400 MHz.
5. Values are based on 10 pF capacitive load.

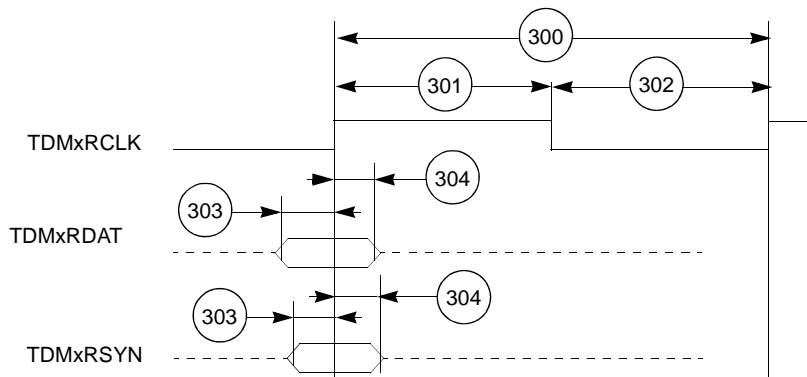

Figure 18. TDM Inputs Signals

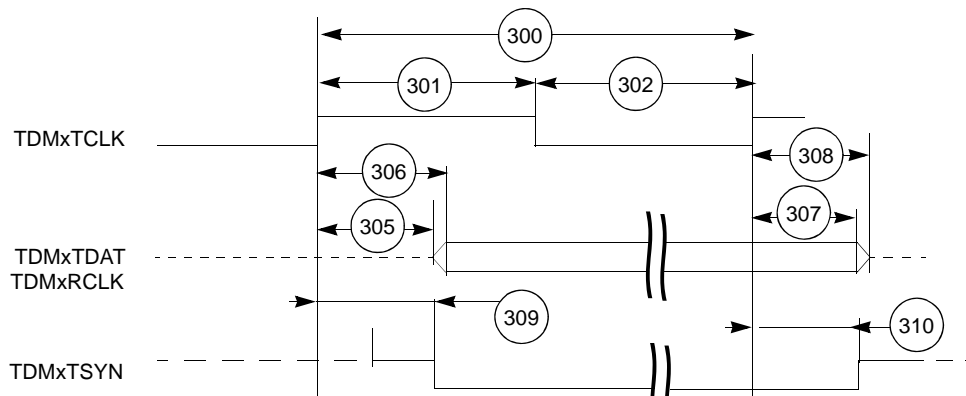

Figure 19. TDM Output Signals

2.5.8 UART Timing

Table 22. UART Timing

No.	Characteristics	Expression	Min	Max	Unit
400	URXD and UTXD inputs high/low duration	$16 \times T_{REFCLK}$	160.0	—	ns
401	URXD and UTXD inputs rise/fall time			10	ns
402	UTXD output rise/fall time			10	ns

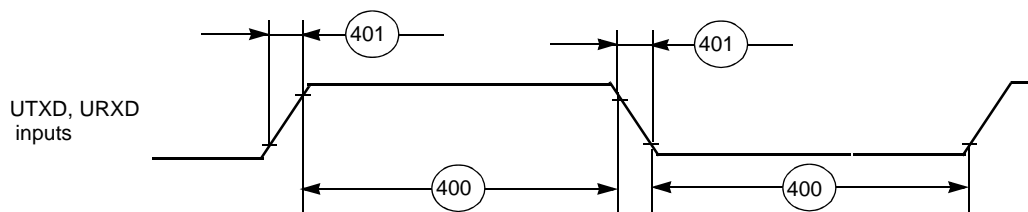

Figure 20. UART Input Timing

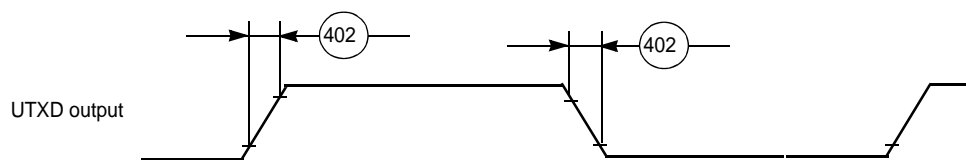

Figure 21. UART Output Timing

2.5.9 Timer Timing

Table 23. Timer Timing

No.	Characteristics	Ref = CLKIN		Unit
		Min	Max	
500	TIMERx frequency	10.0	—	ns
501	TIMERx Input high period	4.0	—	ns
502	TIMERx Output low period	4.0	—	ns
503	TIMERx Propagations delay from its clock input <ul style="list-style-type: none"> • 1.1 V core • 1.2 V core 	3.1	9.5	ns
		2.8	8.1	ns

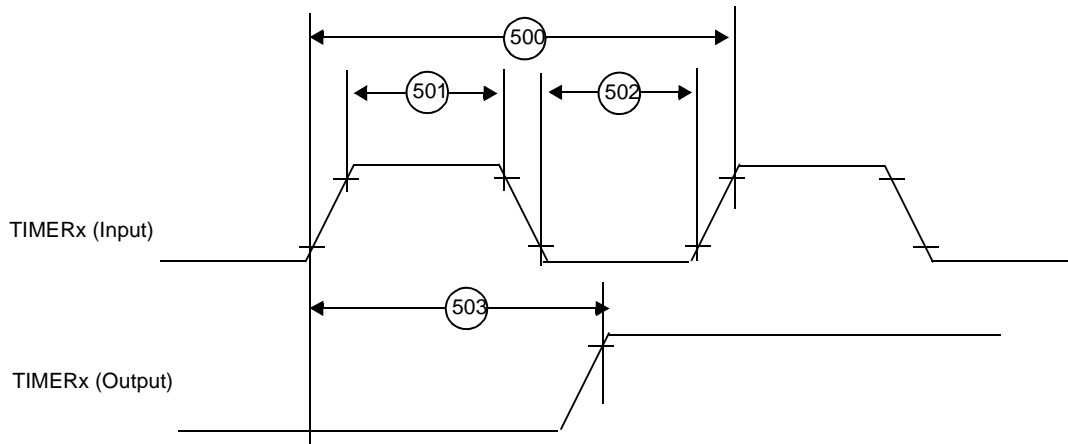

Figure 22. Timer Timing

2.5.10 Ethernet Timing

2.5.10.1 Management Interface Timing

Table 24. Ethernet Controller Management Interface Timing

No.	Characteristics	Min	Max	Unit
801	ETHMDIO to ETHMDC rising edge set-up time	10	—	ns
802	ETHMDC rising edge to ETHMDIO hold time	10	—	ns

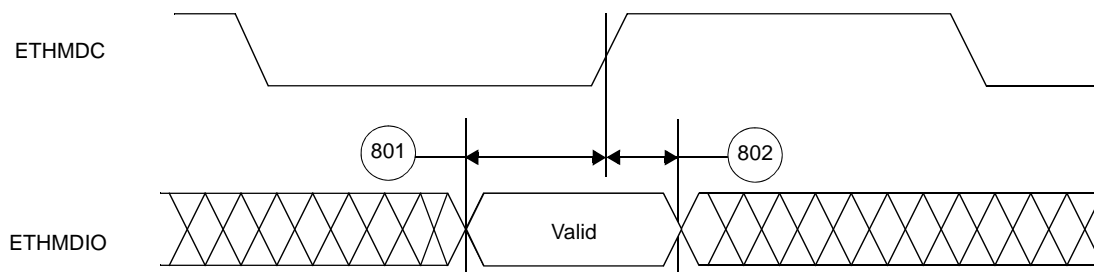

Figure 23. MDIO Timing Relationship to MDC

2.5.10.2 MII Mode Timing

Table 25. MII Mode Signal Timing

No.	Characteristics	Min	Max	Unit
803	ETHRX_DV, ETHRXD[0–3], ETHRX_ER to ETHRX_CLK rising edge set-up time	3.5	—	ns
804	ETHRX_CLK rising edge to ETHRX_DV, ETHRXD[0–3], ETHRX_ER hold time	3.5	—	ns
805	ETHTX_CLK to ETHTX_EN, ETHTXD[0–3], ETHTX_ER output delay	1	14.6	ns
		1	12.6	ns

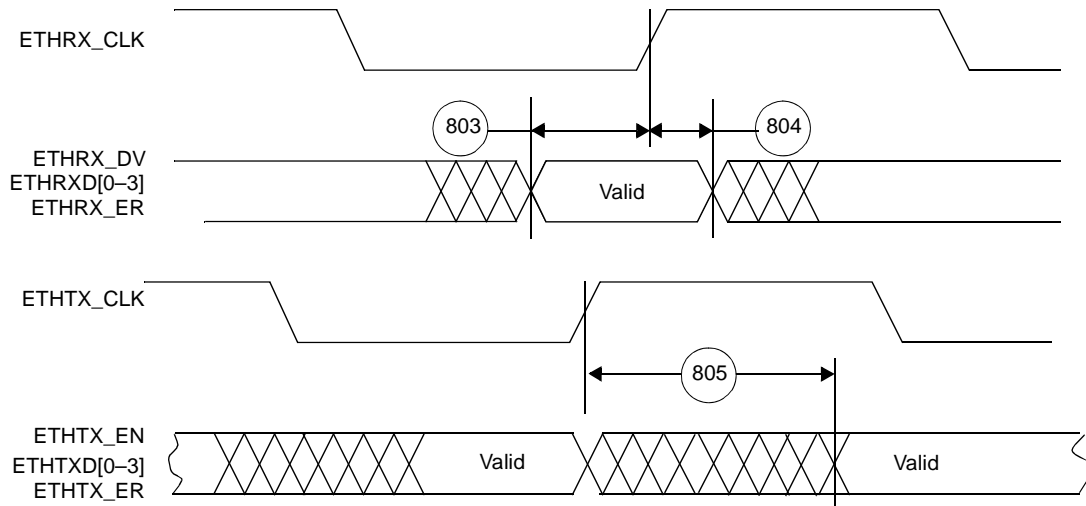

Figure 24. MII Mode Signal Timing

2.5.10.3 RMII Mode

Table 26. RMII Mode Signal Timing

No.	Characteristics	1.1 V Core		1.2 V Core		Unit
		Min	Max	Min	Max	
806	ETHTX_EN, ETHRXD[0–1], ETHCRS_DV, ETHRX_ER to ETHREF_CLK rising edge set-up time	1.6	—	2	—	ns
807	ETHREF_CLK rising edge to ETHRXD[0–1], ETHCRS_DV, ETHRX_ER hold time	1.6	—	1.6	—	ns
811	ETHREF_CLK rising edge to ETHTXD[0–1], ETHTX_EN output delay.	3	12.5	3	11	ns

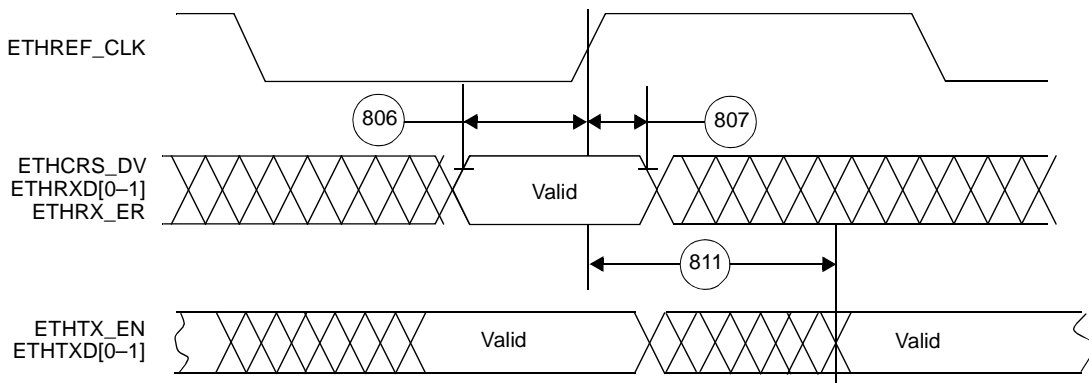

Figure 25. RMII Mode Signal Timing

2.5.10.4 SMII Mode

Table 27. SMII Mode Signal Timing

No.	Characteristics	Min	Max	Unit
808	ETHSYNC_IN, ETHRXD to ETHCLOCK rising edge set-up time	1.0	—	ns
809	ETHCLOCK rising edge to ETHSYNC_IN, ETHRXD hold time	1.0	—	ns
810	ETHCLOCK rising edge to ETHSYNC, ETHTXD output delay	1.5 ¹ 1.5 ¹	6.0 ² 5.0 ²	ns ns
Notes:	1. Measured using a 5 pF load. 2. Measured using a 15 pF load.			

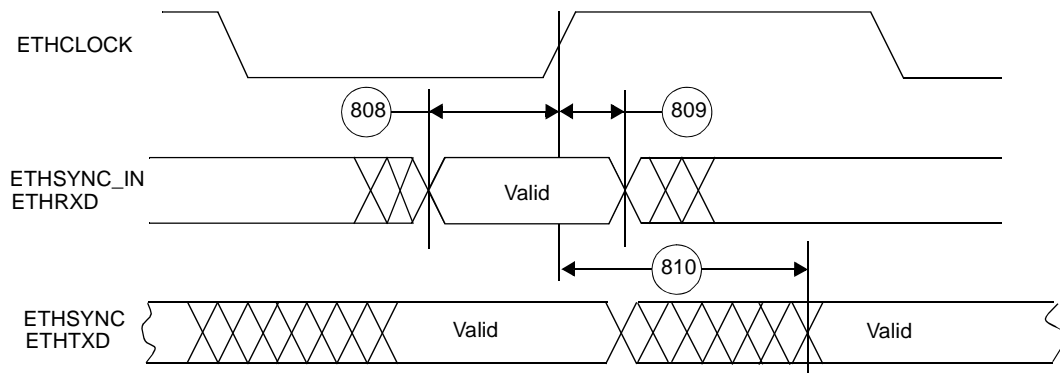

Figure 26. SMII Mode Signal Timing

2.5.11 GPIO Timing

Table 28. GPIO Timing

No.	Characteristics	Ref = CLKIN		Ref = CLKOUT		Unit
		Min	Max	Min	Max	
601	REFCLK edge to GPIO out valid (GPIO out delay time)	—	6.1	—	6.9	ns
602	REFCLK edge to GPIO out not valid (GPIO out hold time)	1.1	—	1.3	—	ns
603	REFCLK edge to high impedance on GPIO out	—	5.4	—	6.2	ns
604	GPIO in valid to REFCLK edge (GPIO in set-up time)	3.5	—	3.7	—	ns
605	REFCLK edge to GPIO in not valid (GPIO in hold time)	0.5	—	0.5	—	ns

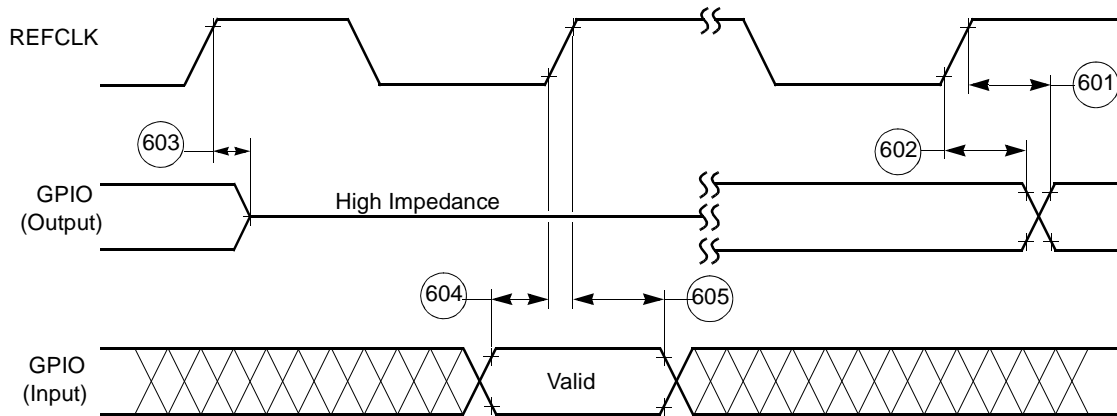

Figure 27. GPIO Timing

2.5.12 EE Signals

Table 29. EE Pin Timing

Number	Characteristics	Type	Min
65	EE0 (input)	Asynchronous	4 core clock periods
66	EE1 (output)	Synchronous to Core clock	1 core clock period

- Notes:
1. The core clock is the SC140 core clock. The ratio between the core clock and CLKOUT is configured during power-on-reset.
 2. Refer to **Table 1-4** on page 1-6 for details on EE pin functionality.

Figure 28 shows the signal behavior of the EE pins.

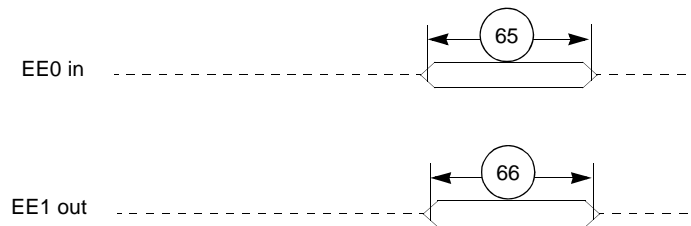

Figure 28. EE Pin Timing

2.5.13 JTAG Signals

Table 30. JTAG Timing

No.	Characteristics	All frequencies		Unit
		Min	Max	
700	TCK frequency of operation ($1/(T_C \times 4)$; maximum 25 MHz)	0.0	25	MHz
701	TCK cycle time	40.0	—	ns
702	TCK clock pulse width measured at $V_M = 1.6$ V	High	—	ns
		Low	—	ns
703	TCK rise and fall times	0.0	3.0	ns

Table 30. JTAG Timing (continued)

No.	Characteristics	All frequencies		Unit
		Min	Max	
704	Boundary scan input data set-up time	5.0	—	ns
705	Boundary scan input data hold time	20.0	—	ns
706	TCK low to output data valid	0.0	30.0	ns
707	TCK low to output high impedance	0.0	30.0	ns
708	TMS, TDI data set-up time	5.0	—	ns
709	TMS, TDI data hold time	20.0	—	ns
710	TCK low to TDO data valid	0.0	20.0	ns
711	TCK low to TDO high impedance	0.0	20.0	ns
712	TRST assert time	100.0	—	ns
713	TRST set-up time to TCK low	30.0	—	ns

Note: All timings apply to OnCE module data transfers as well as any other transfers via the JTAG port.

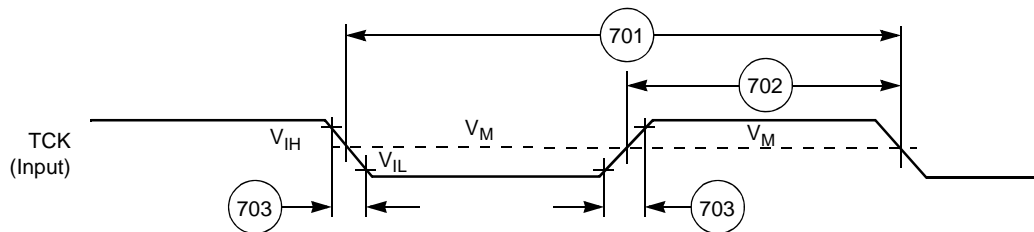

Figure 29. Test Clock Input Timing Diagram

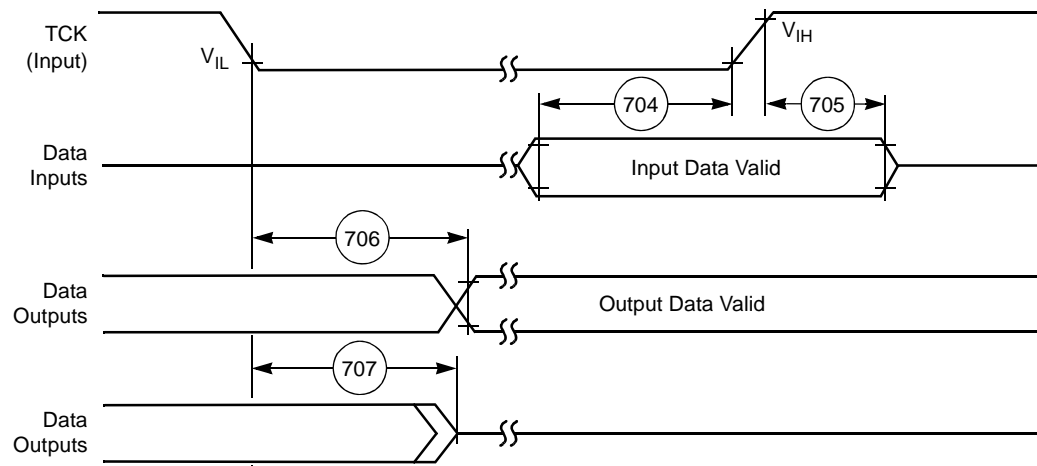

Figure 30. Boundary Scan (JTAG) Timing Diagram

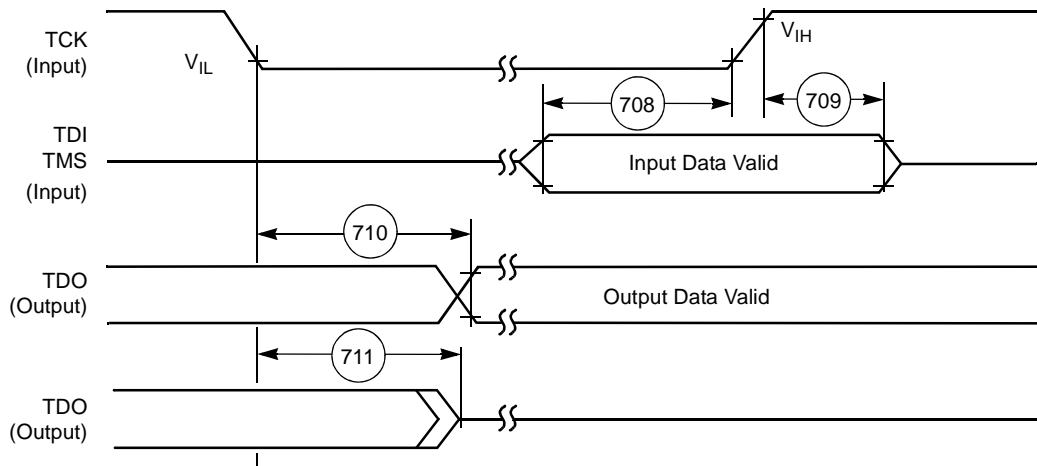

Figure 31. Test Access Port Timing Diagram

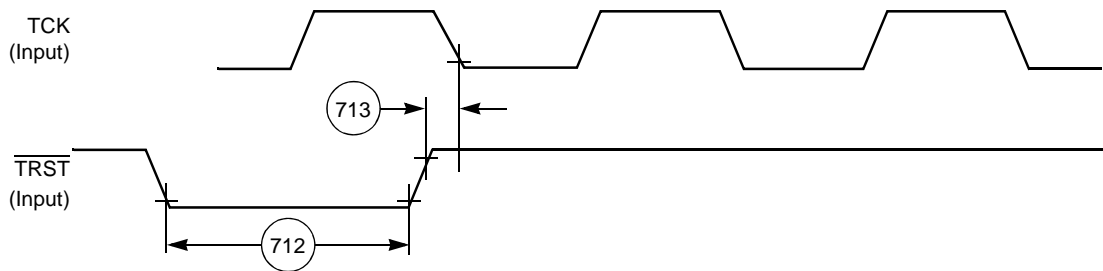

Figure 32. $\overline{\text{TRST}}$ Timing Diagram

3 Hardware Design Considerations

The following sections discuss areas to consider when the MSC8126 device is designed into a system.

3.1 Start-up Sequencing Recommendations

Use the following guidelines for start-up and power-down sequences:

- Assert $\overline{\text{PORESET}}$ and $\overline{\text{TRST}}$ before applying power and keep the signals driven low until the power reaches the required minimum power levels. This can be implemented via weak pull-down resistors.
- CLKIN can be held low or allowed to toggle during the beginning of the power-up sequence. However, CLKIN must start toggling before the deassertion of PORESET and after both power supplies have reached nominal voltage levels.
- If possible, bring up $V_{\text{DD}}/V_{\text{CCSYN}}$ and V_{DDH} together. If it is not possible, raise $V_{\text{DD}}/V_{\text{CCSYN}}$ first and then bring up V_{DDH} . V_{DDH} should not exceed $V_{\text{DD}}/V_{\text{CCSYN}}$ until $V_{\text{DD}}/V_{\text{CCSYN}}$ reaches its nominal voltage level. Similarly, bring both voltage levels down together. If that is not possible reverse the power-up sequence, with V_{DDH} going down first and then $V_{\text{DD}}/V_{\text{CCSYN}}$.

Note: This recommended power sequencing for the MSC8126 is different from the MSC8102. See **Section 2.5.2** for start-up timing specifications.

External voltage applied to any input line must not exceed the I/O supply V_{DDH} by more than 0.8 V at any time, including during power-up. Some designs require pull-up voltages applied to selected input lines during power-up for configuration purposes. This is an acceptable exception to the rule. However, each such input can draw up to 80 mA per input pin per device in the system during start-up.

During the power-up sequence, if V_{DD} rises before V_{DDH} (see **Figure 6**), current can pass from the V_{DD} supply through the device ESD protection circuits to the V_{DDH} supply. The ESD protection diode can allow this to occur when V_{DD} exceeds V_{DDH} by more than 0.8 V. Design the power supply to prevent or minimize this effect using one of the following optional methods:

- Never allow V_{DD} to exceed $V_{\text{DDH}} + 0.8\text{V}$.
- Design the V_{DDH} supply to prevent reverse current flow by adding a minimum 10 Ω resistor to GND to limit the current. Such a design yields an initial V_{DDH} level of $V_{\text{DD}} - 0.8\text{V}$ before it is enabled.

After power-up, V_{DDH} must not exceed $V_{\text{DD}}/V_{\text{CCSYN}}$ by more than 2.6 V.

3.2 Power Supply Design Considerations

When used as a drop-in replacement in MSC8102 applications or when implementing a new design, use the guidelines described in *Migrating Designs from the MSC8102 to the MSC8122* (AN2716) and the *MSC8126 Design Checklist* (AN3374) for optimal system performance. *MSC8122 and MSC8126 Power Circuit Design Recommendations and Examples* (AN2937) provides detailed design information. See **Section 2.5.2** for start-up timing specifications.

Figure 33 shows the recommended power decoupling circuit for the core power supply. The voltage regulator and the decoupling capacitors should supply the required device current without any drop in voltage on the device pins. The voltage on the package pins should not drop below the minimum specified voltage level even for a very short spikes. This can be achieved by using the following guidelines:

- For the core supply, use a voltage regulator rated at 1.2 V with nominal rating of at least 3 A. This rating does not reflect actual average current draw, but is recommended because it resists changes imposed by transient spikes and has better voltage recovery time than supplies with lower current ratings.

- Decouple the supply using low-ESR capacitors mounted as close as possible to the socket. **Figure 33** shows three capacitors in parallel to reduce the resistance. Three capacitors is a recommended minimum number. If possible, mount at least one of the capacitors directly below the MSC8126 device.

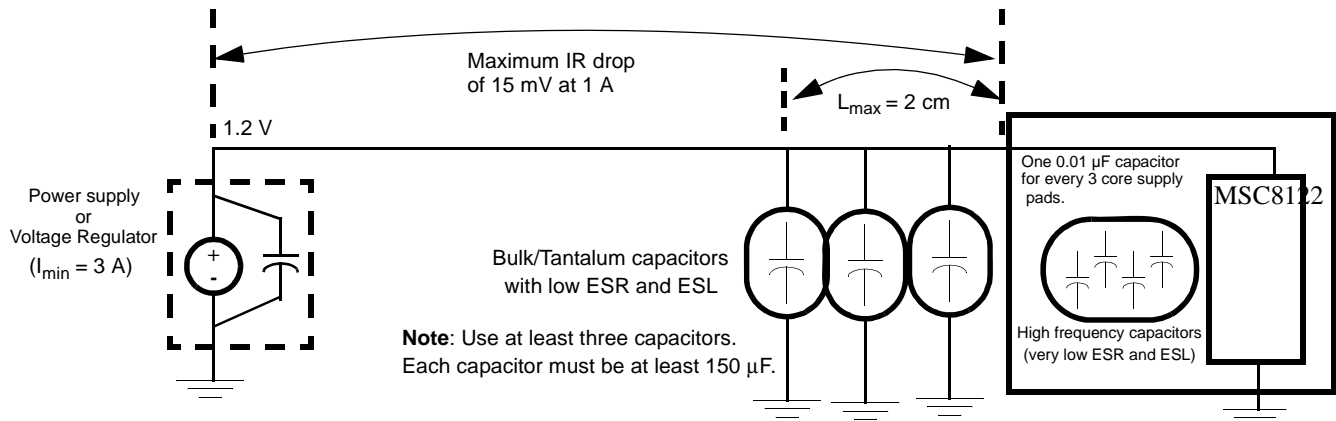

Figure 33. Core Power Supply Decoupling

Each V_{CC} and V_{DD} pin on the MSC8126 device should have a low-impedance path to the board power supply. Similarly, each GND pin should have a low-impedance path to the ground plane. The power supply pins drive distinct groups of logic on the chip. The V_{CC} power supply should have at least four 0.1 μF by-pass capacitors to ground located as closely as possible to the four sides of the package. The capacitor leads and associated printed circuit traces connecting to chip V_{CC} , V_{DD} , and GND should be kept to less than half an inch per capacitor lead. A four-layer board is recommended, employing two inner layers as V_{CC} and GND planes.

All output pins on the MSC8126 have fast rise and fall times. PCB trace interconnection length should be minimized to minimize undershoot and reflections caused by these fast output switching times. This recommendation particularly applies to the address and data buses. Maximum PCB trace lengths of six inches are recommended. For the DSI control signals in synchronous mode, ensure that the layout supports the DSI AC timing requirements and minimizes any signal crosstalk. Capacitance calculations should consider all device loads as well as parasitic capacitances due to the PCB traces. Attention to proper PCB layout and bypassing becomes especially critical in systems with higher capacitive loads because these loads create higher transient currents in the V_{CC} , V_{DD} , and GND circuits. Pull up all unused inputs or signals that will be inputs during reset.

Special care should be taken to minimize the noise levels on the PLL supply pins: V_{CCSYN} - GND_{SYN} . To ensure internal clock stability, filter the power to the V_{CCSYN} input with a circuit similar to the one in **Figure 34**. For optimal noise filtering, place the circuit as close as possible to V_{CCSYN} . The 0.01- μF capacitor should be closest to V_{CCSYN} , followed by the 10- μF capacitor, the 10-nH inductor, and finally the 10- Ω resistor to V_{DD} . These traces should be kept short and direct. Provide an extremely low impedance path to the ground plane for GND_{SYN} . Bypass GND_{SYN} to V_{CCSYN} by a 0.01- μF capacitor located as close as possible to the chip package. For best results, place this capacitor on the backside of the PCB aligned with the depopulated void on the MSC8126 located in the square defined by positions, L11, L12, L13, M11, M12, M13, N11, N12, and N13.

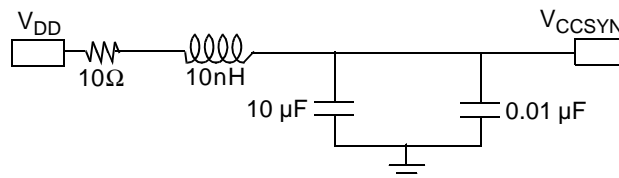

Figure 34. V_{CCSYN} Bypass

3.3 Connectivity Guidelines

Unused output pins can be disconnected, and unused input pins should be connected to the non-active value, via resistors to V_{DDH} or GND, except for the following:

- If the DSI is unused (DDR[DSIDIS] is set), \overline{HCS} and \overline{HBCS} must be pulled up and all the rest of the DSI signals can be disconnected.
- When the DSI uses synchronous mode, \overline{HTA} must be pulled up. In asynchronous mode, \overline{HTA} should be pulled either up or down, depending on design requirements.
- \overline{HDST} can be disconnected if the DSI is in big-endian mode, or if the DSI is in little-endian mode and the DCR[DSRFA] bit is set.
- When the DSI is in 64-bit data bus mode and DCR[BEM] is cleared, pull up $\overline{HWBS[1-3]}/\overline{HDBS[1-3]}/\overline{HWBE[1-3]}/\overline{HDBE[1-3]}$ and $\overline{HWBS[4-7]}/\overline{HDBS[4-7]}/\overline{HWBE[4-7]}/\overline{HDBE[4-7]}/\overline{PWE[4-7]}/\overline{PSDDQM[4-7]}/\overline{PBS[4-7]}$.
- When the DSI is in 32-bit data bus mode and DCR[BEM] is cleared, $\overline{HWBS[1-3]}/\overline{HDBS[1-3]}/\overline{HWBE[1-3]}/\overline{HDBE[1-3]}$ must be pulled up.
- When the DSI is in asynchronous mode, \overline{HBRST} and HCLKIN should either be disconnected or pulled up.
- When the DSI uses sliding window address mode (DCR[SLDWA] = 1), the external HA[11-13] signals must be connected (tied) to the correct voltage levels so that the host can perform the first access to the DCR. After reset, the DSI expects full address mode (DCR[SLDWA] = 0). The DCR address in the DSI memory map is 0x1BE000, which requires the following connections:
 - HA11 must be pulled high (1)
 - HA12 must be pulled high (1)
 - HA13 must be pulled low (0)
- The following signals must be pulled up: \overline{HRESET} , \overline{SRESET} , \overline{ARTRY} , \overline{TA} , \overline{TEA} , \overline{PSDVAL} , and \overline{AACK} .
- In single-master mode (BCR[EBM] = 0) with internal arbitration (PPC_ACR[EARB] = 0):
 - \overline{BG} , \overline{DBG} , and \overline{TS} can be left unconnected.
 - $\overline{EXT_BG[2-3]}$, $\overline{EXT_DBG[2-3]}$, and \overline{GBL} can be left unconnected if they are multiplexed to the system bus functionality. For any other functionality, connect the signal lines based on the multiplexed functionality.
 - \overline{BR} must be pulled up.
 - $\overline{EXT_BR[2-3]}$ must be pulled up if multiplexed to the system bus functionality.
- If there is an external bus master (BCR[EBM] = 1):
 - \overline{BR} , \overline{BG} , \overline{DBG} , and \overline{TS} must be pulled up.
 - $\overline{EXT_BR[2-3]}$, $\overline{EXT_BG[2-3]}$, and $\overline{EXT_DBG[2-3]}$ must be pulled up if multiplexed to the system bus functionality.
- In single-master mode, \overline{ABB} and \overline{DBB} can be selected as \overline{IRQ} inputs and be connected to the non-active value. In other modes, they must be pulled up.

Note: The MSC8126 does not support DLL-enabled mode. For the following two clock schemes, ensure that the DLL is disabled (that is, the DLLDIS bit in the Hard Reset Configuration Word is set).

- If no system synchronization is required (for example, the design does not use SDRAM), you can use any of the available clock modes.
- In the CLKIN synchronization mode, use the following connections:
 - Connect the oscillator output through a buffer to CLKIN.
 - Connect the CLKIN buffer output to the slave device (for example, SDRAM) making sure that the delay path between the clock buffer to the MSC8126 and the SDRAM is equal (that is, has a skew less than 100 ps).
 - Valid clock modes in this scheme are: 0, 7, 15, 19, 21, 23, 28, 29, 30, and 31.
- In CLKOUT synchronization mode (for 1.2 V devices), CLKOUT is the main clock to SDRAM. Use the following connections:
 - Connect the oscillator output through a buffer to CLKIN.
 - Connect CLKOUT through a zero-delay buffer to the slave device (for example, SDRAM) using the following guidelines:
 - The maximum delay between the slave and CLKOUT must not exceed 0.7 ns.

- The maximum load on CLKOUT must not exceed 10 pF.
- Use a zero-delay buffer with a jitter less than 0.3 ns.
- All clock modes are valid in this clock scheme.

Note: See the Clock chapter in the *MSC8122 Reference Manual* for details.

- If the 60x-compatible system bus is not used and SIUMCR[PBSE] is set, $\overline{\text{PPBS}}$ can be disconnected. Otherwise, it should be pulled up.
- The following signals: SWTE, DSISYNC, DSI64, MODCK[1–2], CNFGS, CHIPID[0–3], RSTCONF and BM[0–2] are used to configure the MSC8126 and are sampled on the deassertion of the $\overline{\text{PORESET}}$ signal. Therefore, they should be tied to GND or V_{DDH} or through a pull-down or a pull-up resistor until the deassertion of the $\overline{\text{PORESET}}$ signal.
- When they are used, $\overline{\text{INT_OUT}}$ (if SIUMCR[INTODC] is cleared), $\overline{\text{NMI_OUT}}$, and $\overline{\text{IRQxx}}$ (if not full drive) signals must be pulled up.
- When the Ethernet controller is enabled and the SMII mode is selected, GPIO10 and GPIO14 must not be connected externally to any signal line.

Note: For details on configuration, see the *MSC8126 User's Guide* and *MSC8126 Reference Manual*. For additional information, refer to the *MSC8126 Design Checklist* (AN2903).

3.4 External SDRAM Selection

The external bus speed implemented in a system determines the speed of the SDRAM used on that bus. However, because of differences in timing characteristics among various SDRAM manufacturers, you may have to use a faster speed rated SDRAM to assure efficient data transfer across the bus. For example, for 166 MHz operation, you may have to use 183 or 200 MHz SDRAM. Always perform a detailed timing analysis using the MSC8126 bus timing values and the manufacturer specifications for the SDRAM to ensure correct operation within your system design. The output delay listed in SDRAM specifications is usually given for a load of 30 pF. Scale the number to your specific board load using the typical scaling number provided by the SDRAM manufacturer.

3.5 Thermal Considerations

An estimation of the chip-junction temperature, T_J , in °C can be obtained from the following:

$$T_J = T_A + (R_{\theta JA} \times P_D) \quad \text{Eqn. 1}$$

where

- T_A = ambient temperature near the package (°C)
- $R_{\theta JA}$ = junction-to-ambient thermal resistance (°C/W)
- $P_D = P_{INT} + P_{I/O}$ = power dissipation in the package (W)
- $P_{INT} = I_{DD} \times V_{DD}$ = internal power dissipation (W)
- $P_{I/O}$ = power dissipated from device on output pins (W)

The power dissipation values for the MSC8126 are listed in **Table 2-3**. The ambient temperature for the device is the air temperature in the immediate vicinity that would cool the device. The junction-to-ambient thermal resistances are JEDEC standard values that provide a quick and easy estimation of thermal performance. There are two values in common usage: the value determined on a single layer board and the value obtained on a board with two planes. The value that more closely approximates a specific application depends on the power dissipated by other components on the printed circuit board (PCB). The value obtained using a single layer board is appropriate for tightly packed PCB configurations. The value obtained using a board with internal planes is more appropriate for boards with low power dissipation (less than 0.02 W/cm² with natural convection) and well separated components. Based on an estimation of junction temperature using this technique, determine whether a more detailed thermal analysis is required. Standard thermal management techniques can be used to maintain the device thermal junction temperature below its maximum. If T_J appears to be too high, either lower the ambient temperature or the power dissipation of the chip. You can verify the junction temperature by measuring the case temperature using a small diameter thermocouple (40 gauge is recommended) or an infrared temperature sensor on a spot on the device case that is painted black. The MSC8126 device case surface is too shiny (low emissivity) to yield an accurate infrared temperature measurement. Use the following equation to determine T_J :

$$T_J = T_T + (\theta_{JA} \times P_D) \quad \text{Eqn. 2}$$

where

- T_T = thermocouple (or infrared) temperature on top of the package (°C)
- θ_{JA} = thermal characterization parameter (°C/W)
- P_D = power dissipation in the package (W)

Note: See *MSC8102, MSC8122, and MSC8126 Thermal Management Design Guidelines (AN2601/D)*.

4 Ordering Information

Consult a Freescale Semiconductor sales office or authorized distributor to determine product availability and place an order.

Part	Package Type	Spheres	Core Voltage	Operating Temperature	Core Frequency (MHz)	Order Number
MSC8126	Flip Chip Plastic Ball Grid Array (FC-PBGA)	Lead-free	1.2 V	-40° to 105°C	400	MSC8126TVT6400
		Lead-bearing				MSC8126TMP6400
		Lead-free	0° to 90°C	500	MSC8126VT8000	
		Lead-bearing			MSC8126MP8000	

5 Package Information

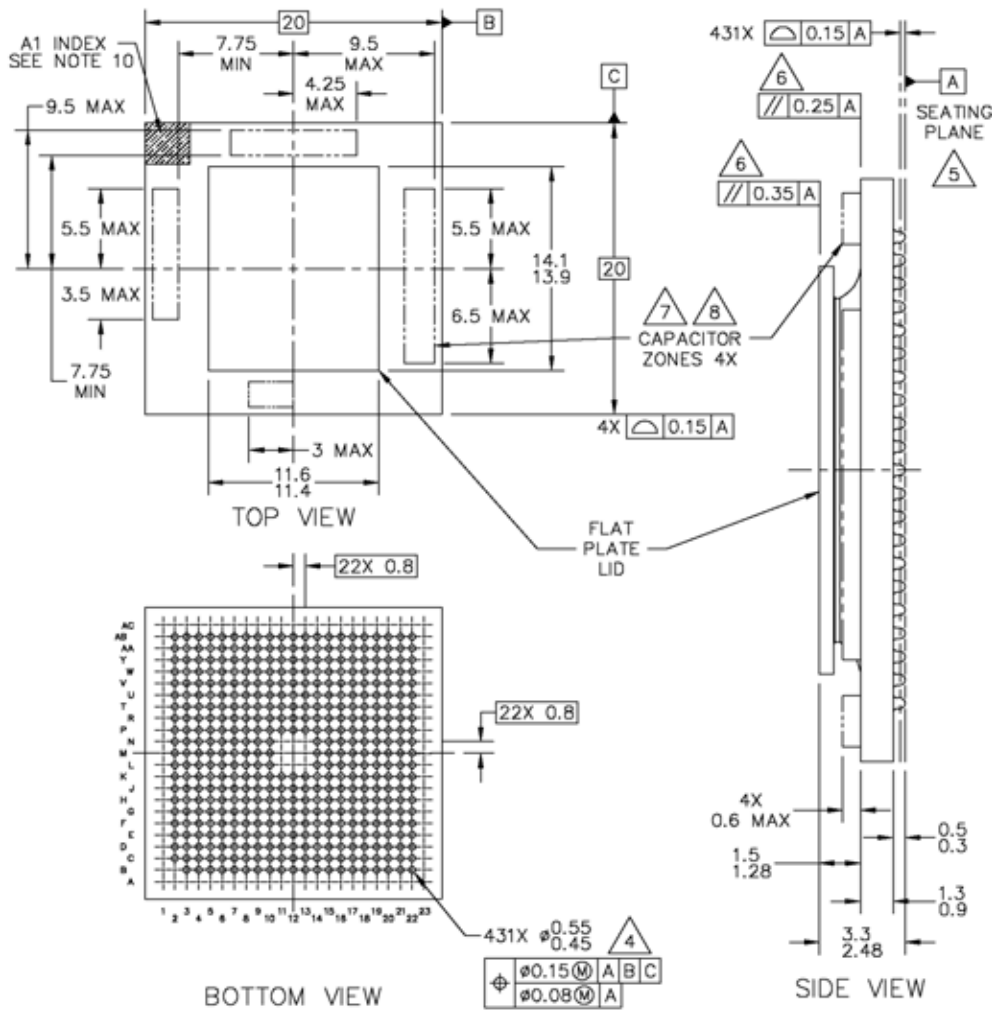

Notes:

- 1. All dimensions in millimeters.
- 2. Dimensioning and tolerancing per ASME Y14.5M-1994.
- 3. Features are symmetrical about the package center lines unless dimensioned otherwise.
- △ Maximum solder ball diameter measured parallel to Datum A.
- △ Datum A, the seating plane, is determined by the spherical crowns of the solder balls.
- △ Parallelism measurement shall exclude any effect of mark on top surface of package.
- △ Capacitors may not be present on all devices.
- △ Caution must be taken not to short capacitors or exposed metal capacitor pads on package top.
- △ FC CBGA (Ceramic) package code: 5238.
FC PBGA (Plastic) package code: 5263.
- 10. Pin 1 indicator can be in the form of number 1 marking or an "L" shape marking.

Figure 35. MSC8126 Mechanical Information, 431-pin FC-PBGA Package

6 Product Documentation

- *MSC8126 Technical Data Sheet* (MSC8126). Details the signals, AC/DC characteristics, clock signal characteristics, package and pinout, and electrical design considerations of the MSC8126 device.
- *MSC8126 Reference Manual* (MSC8126RM). Includes functional descriptions of the extended cores and all the internal subsystems including configuration and programming information.
- *Application Notes*. Cover various programming topics related to the StarCore DSP core and the MSC8126 device.
- *SC140 DSP Core Reference Manual*. Covers the SC140 core architecture, control registers, clock registers, program control, and instruction set.

7 Revision History

Table 31 provides a revision history for this data sheet.

Table 31. Document Revision History

Revision	Date	Description
0	May 2004	<ul style="list-style-type: none"> Initial release.
1	Jun. 2004	<ul style="list-style-type: none"> Updated timing number 32b. Updated DSI timing specifications.
2	Sep 2004	<ul style="list-style-type: none"> New orderable parts added with other core voltage and temperature options. Updated thermal characteristics. In Table 2-14, removed references to 30 pF. Design guidelines and layout recommendations updated.
3	Nov. 2004	<ul style="list-style-type: none"> Added 500 MHz core and 166 MHz bus speed options. Definitions of GPIO[27–28] updated. Bus, TDM, and GPIO timing updated. I²C timing changed to GPIO timing. GPIO[27–28] connections updated. MWBE_n replaced with correct name HWBE_n. Design guidelines update.
4	Jan. 2005	<ul style="list-style-type: none"> Package type changed to FC-PBGA for all frequencies. Low-voltage 300 MHz power changed to 1.1 V. $\overline{\text{HRESET}}$ and $\overline{\text{SRESET}}$ definitions updated. Undershoot and overshoot values added for V_{DDH}. RMI timing updated. Design guidelines updated and reorganized.
5	May 2005	<ul style="list-style-type: none"> Multiple AC timing specifications updated.
6	May 2005	<ul style="list-style-type: none"> Multiple AC timing specifications updated.
7	Jul. 2005	<ul style="list-style-type: none"> Multiple AC timing specifications updated.
8	Jul. 2005	<ul style="list-style-type: none"> AC specification table layout modified.
9	Sep. 2005	<ul style="list-style-type: none"> ETH_{TX}_EN type and $\overline{\text{TRST}}$ description updated. Package drawing updated. Clock specifications updated. Start-up sequence updated.
10	Oct 2005	<ul style="list-style-type: none"> V_{DDH} + 10% changed to V_{DDH} + 8% in Figure 2-1. V_{DDH} + 20% changed to V_{DDH} + 17% in Figure 2-1.
11	Apr 2006	<ul style="list-style-type: none"> Reset timing updated to reflect actual values in Table 2-11.
12	Oct. 2006	<ul style="list-style-type: none"> Added new timings 17 and 18 for IRQ set time and pulse width in Table 2-13
13	Dec. 2007	<ul style="list-style-type: none"> Converted to new data sheet format. Added PLL supply current to Table 5 in Section 2.4. Modified Figure 5 in Section 2.4 to make it clear that the time limits for undershoot referred to values below –0.3 V and not GND. Added cross-references between Sections 2.5.2 and Section 3.1 and 3.2. Added power-sequence guidelines to Sections 2.5.2. Added CLKIN jitter characteristic specifications to Table 9. Added additional guidelines to prevent reverse current to Section 3.1. Added connectivity guidelines for DSI in sliding windows mode to Section 3.3.
14	May 2008	<ul style="list-style-type: none"> Changed V_{IL} maximum and reference value to 0.8 V in Table 5.
15	Dec 2008	<ul style="list-style-type: none"> Clarified the wording of note 2 in Table 15 on p. 24.

How to Reach Us:

Home Page:

www.freescale.com

Web Support:

<http://www.freescale.com/support>

USA/Europe or Locations Not Listed:

Freescale Semiconductor, Inc.
Technical Information Center, EL516
2100 East Elliot Road
Tempe, Arizona 85284
+1-800-521-6274 or
+1-480-768-2130
www.freescale.com/support

Europe, Middle East, and Africa:

Freescale Halbleiter Deutschland GmbH
Technical Information Center
Schatzbogen 7
81829 Muenchen, Germany
+44 1296 380 456 (English)
+46 8 52200080 (English)
+49 89 92103 559 (German)
+33 1 69 35 48 48 (French)
www.freescale.com/support

Japan:

Freescale Semiconductor Japan Ltd.
Headquarters
ARCO Tower 15F
1-8-1, Shimo-Meguro, Meguro-ku
Tokyo 153-0064
Japan
0120 191014 or
+81 3 5437 9125
support.japan@freescale.com

Asia/Pacific:

Freescale Semiconductor China Ltd.
Exchange Building 23F
No. 118 Jianguo Road
Chaoyang District
Beijing 100022
China
+86 010 5879 8000
support.asia@freescale.com

For Literature Requests Only:

Freescale Semiconductor
Literature Distribution Center
P.O. Box 5405
Denver, Colorado 80217
+1-800 441-2447 or
+1-303-675-2140
Fax: +1-303-675-2150
LDCForFreescaleSemiconductor@hibbertgroup.com

Information in this document is provided solely to enable system and software implementers to use Freescale Semiconductor products. There are no express or implied copyright licenses granted hereunder to design or fabricate any integrated circuits or integrated circuits based on the information in this document.

Freescale Semiconductor reserves the right to make changes without further notice to any products herein. Freescale Semiconductor makes no warranty, representation or guarantee regarding the suitability of its products for any particular purpose, nor does Freescale Semiconductor assume any liability arising out of the application or use of any product or circuit, and specifically disclaims any and all liability, including without limitation consequential or incidental damages. "Typical" parameters that may be provided in Freescale Semiconductor data sheets and/or specifications can and do vary in different applications and actual performance may vary over time. All operating parameters, including "Typicals", must be validated for each customer application by customer's technical experts. Freescale Semiconductor does not convey any license under its patent rights nor the rights of others. Freescale Semiconductor products are not designed, intended, or authorized for use as components in systems intended for surgical implant into the body, or other applications intended to support or sustain life, or for any other application in which the failure of the Freescale Semiconductor product could create a situation where personal injury or death may occur. Should Buyer purchase or use Freescale Semiconductor products for any such unintended or unauthorized application, Buyer shall indemnify and hold Freescale Semiconductor and its officers, employees, subsidiaries, affiliates, and distributors harmless against all claims, costs, damages, and expenses, and reasonable attorney fees arising out of, directly or indirectly, any claim of personal injury or death associated with such unintended or unauthorized use, even if such claim alleges that Freescale Semiconductor was negligent regarding the design or manufacture of the part.

RoHS-compliant and/or Pb-free versions of Freescale products have the functionality and electrical characteristics as their non-RoHS-compliant and/or non-Pb-free counterparts. For further information, see <http://www.freescale.com> or contact your Freescale sales representative.

For information on Freescale's Environmental Products program, go to <http://www.freescale.com/epp>.

Freescale™, the Freescale logo, CodeWarrior, StarCore, and QUICC Engine are trademarks of Freescale Semiconductor, Inc. RapidIO is a registered trademark of the RapidIO Trade Association. All other product or service names are the property of their respective owners.

© Freescale Semiconductor, Inc. 2004, 2008. All rights reserved.

Document Number: MSC8126
Rev. 15
12/2008

