

## THIN POWER ROCKER SWITCH

# TR Series

### Features

- 16A switching in 11mm wide package
- Lighted and non-lighted versions
- Available in a wide variety of colors
- Double-throw and three-position versions available
- Fits industry-standard cut-outs
- Mechanical life: min. 50,000 operations

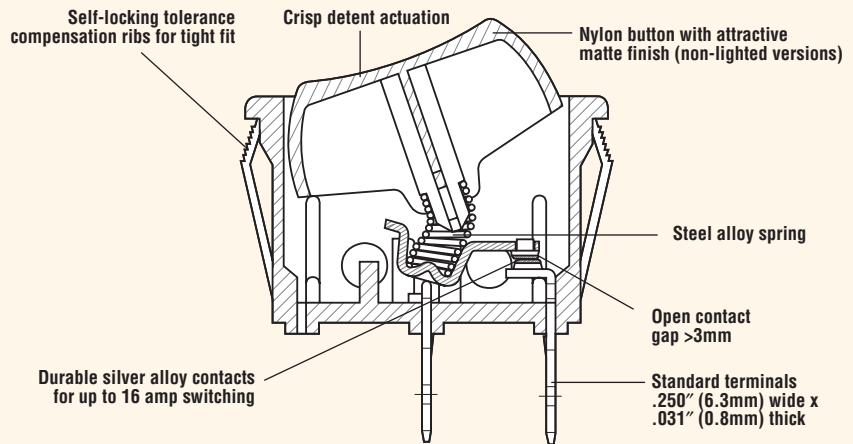

### Electrical Ratings

Switch Series	EN61058 Rating	UL1054 Rating	Electrical Life at Rated Load	
			According to VDE (Min. Operations)	According to UL (Min. Operations)
TR	16(4)A, 250V~, T85 1E4	16A, 125/250VAC, 1/4HP@125V; 3/4HP@250V	10,000	6,000

### Specifications

#### Electrical

Dielectric Strength:	1000VAC for 1 minute
Insulation Resistance:	10 <sup>9</sup> ohms min at 500VDC
Initial Contact Resistance:	0.020 ohms max
Temperature Range:	-20°C to +65°C

#### Materials

Actuator (non-lighted):	Nylon 66 94V-2
Actuator (lighted):	Polycarbonate
Case:	Nylon 66 94V-2
Spring:	Steel Wire
Contacts:	Silver Alloy
Movable Arm:	Silver-Plated Copper Alloy
Fixed Contact Terminals:	Tin-Plated Copper Alloy



