

LM1086

1.5A Low Dropout Positive Regulators

General Description

The LM1086 is a series of low dropout positive voltage regulators with a maximum dropout of 1.5V at 1.5A of load current. It has the same pin-out as National Semiconductor's industry standard LM317.

The LM1086 is available in an adjustable version, which can set the output voltage with only two external resistors. It is also available in six fixed voltages: 1.8V, 2.5V, 2.85V, 3.3V, 3.45V and 5.0V. The fixed versions integrate the adjust resistors.

The LM1086 circuit includes a zener trimmed bandgap reference, current limiting and thermal shutdown.

The LM1086 series is available in TO-220, TO-263, and LLP packages. Refer to the LM1084 for the 5A version, and the LM1085 for the 3A version.

Features

- Available in 1.8V, 2.5V, 2.85V, 3.3V, 3.45V, 5V and Adjustable Versions
- Current Limiting and Thermal Protection
- Output Current 1.5A
- Line Regulation 0.015% (typical)
- Load Regulation 0.1% (typical)

Applications

- SCSI-2 Active Terminator
- High Efficiency Linear Regulators
- Battery Charger
- Post Regulation for Switching Supplies
- Constant Current Regulator
- Microprocessor Supply

Connection Diagrams

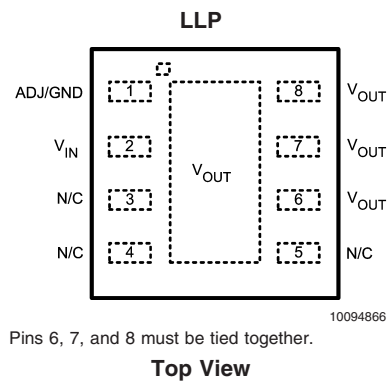
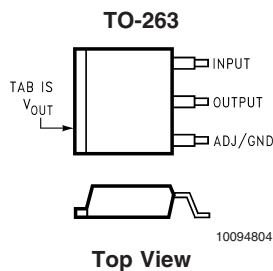
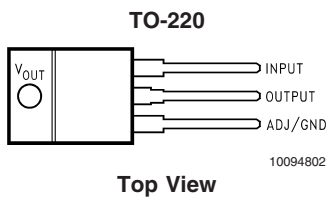

Basic Functional Diagram, Adjustable Version

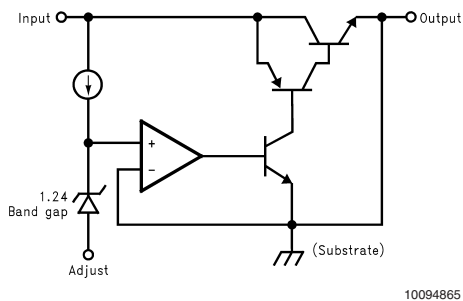

Application Circuit

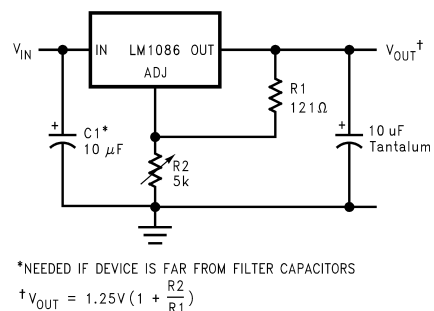

1.2V to 15V Adjustable Regulator

Ordering Information

Package	Temperature Range	Part Number	Transport Media	NSC Drawing
3-lead TO-263	-40°C to +125°C	LM1086IS-ADJ	Rails	TS3B
		LM1086ISX-ADJ	Tape and Reel	
		LM1086IS-1.8	Rails	
		LM1086ISX-1.8	Tape and Reel	
		LM1086IS-2.85	Rails	
		LM1086ISX-2.85	Tape and Reel	
		LM1086IS-3.3	Rails	
		LM1086ISX-3.3	Tape and Reel	
		LM1086IS-3.45	Rails	
		LM1086ISX-3.45	Tape and Reel	
	LM1086IS-5.0	Rails		
	LM1086ISX-5.0	Tape and Reel		
	0°C to +125°C	LM1086CS-ADJ	Rails	
		LM1086CSX-ADJ	Tape and Reel	
		LM1086CS-2.5	Rails	
		LM1086CSX-2.5	Tape and Reel	
		LM1086CS-2.85	Rails	
		LM1086CSX-2.85	Tape and Reel	
		LM1086CS-3.3	Rails	
		LM1086CSX-3.3	Tape and Reel	
LM1086CS-5.0		Rails		
LM1086CSX-5.0		Tape and Reel		
3-lead TO-220	-40°C to +125°C	LM1086IT-ADJ	Rails	T03B
		LM1086IT-1.8	Rails	
		LM1086IT-2.85	Rails	
		LM1086IT-3.3	Rails	
		LM1086IT-5.0	Rails	
	0°C to +125°C	LM1086CT-ADJ	Rails	
		LM1086CT-2.85	Rails	
		LM1086CT-3.3	Rails	
		LM1086CT-5.0	Rails	
8-Lead LLP	-40°C to +125°C	LM1086ILD-ADJ	Rails	LDC008AA
		LM1086ILD-ADJ	Tape and Reel	
		LM1086ILD-1.8	Rails	
		LM1086ILD-1.8	Tape and Reel	
		LM1086ILD-2.5	Rails	
		LM1086ILD-2.5	Tape and Reel	
		LM1086ILD-2.85	Rails	
		LM1086ILD-2.85	Tape and Reel	
		LM1086ILD-3.3	Rails	
		LM1086ILD-3.3	Tape and Reel	
		LM1086ILD-5.0	Rails	
LM1086ILD-5.0	Tape and Reel			

Absolute Maximum Ratings (Note 1)

If Military/Aerospace specified devices are required, please contact the National Semiconductor Sales Office/Distributors for availability and specifications.

Maximum Input-to-Output Voltage Differential	
LM1086-ADJ	29V
LM1086-1.8	27V
LM1086-2.5	27V
LM1086-2.85	27V
LM1086-3.3	27V
LM1086-3.45	27V
LM1086-5.0	25V
Power Dissipation (Note 2)	Internally Limited
Junction Temperature (T _J)(Note 3)	150°C

Storage Temperature Range	-65°C to 150°C
Lead Temperature	260°C, to 10 sec
ESD Tolerance (Note 4)	2000V

Operating Ratings (Note 1)

Junction Temperature Range (T _J) (Note 3)	
"C" Grade	
Control Section	0°C to 125°C
Output Section	0°C to 150°C
"I" Grade	
Control Section	-40°C to 125°C
Output Section	-40°C to 150°C

Electrical Characteristics

Typicals and limits appearing in normal type apply for T_J = 25°C. Limits appearing in **Boldface** type apply over the entire junction temperature range for operation.

Symbol	Parameter	Conditions	Min (Note 6)	Typ (Note 5)	Max (Note 6)	Units
V _{REF}	Reference Voltage	LM1086-ADJ I _{OUT} = 10mA, V _{IN} -V _{OUT} = 3V 10mA ≤ I _{OUT} ≤ I _{FULL LOAD} , 1.5V ≤ V _{IN} -V _{OUT} ≤ 15V (Note 7)	1.238	1.250	1.262	V
			1.225	1.250	1.270	V
V _{OUT}	Output Voltage (Note 7)	LM1086-1.8 I _{OUT} = 0mA, V _{IN} = 5V 0 ≤ I _{OUT} ≤ I _{FULL LOAD} , 3.3V ≤ V _{IN} ≤ 18V	1.782	1.8	1.818	V
			1.764	1.8	1.836	V
		LM1086-2.5 I _{OUT} = 0mA, V _{IN} = 5V 0 ≤ I _{OUT} ≤ I _{FULL LOAD} , 4.0V ≤ V _{IN} ≤ 18V	2.475	2.50	2.525	V
			2.450	2.50	2.55	V
		LM1086-2.85 I _{OUT} = 0mA, V _{IN} = 5V 0 ≤ I _{OUT} ≤ I _{FULL LOAD} , 4.35V ≤ V _{IN} ≤ 18V	2.82	2.85	2.88	V
			2.79	2.85	2.91	V
		LM1086-3.3 I _{OUT} = 0mA, V _{IN} = 5V 0 ≤ I _{OUT} ≤ I _{FULL LOAD} , 4.75V ≤ V _{IN} ≤ 18V	3.267	3.300	3.333	V
	3.235	3.300	3.365	V		
ΔV _{OUT}	Line Regulation (Note 8)	LM1086-ADJ I _{OUT} = 10mA, 1.5V ≤ (V _{IN} -V _{OUT}) ≤ 15V		0.015	0.2	%
				0.035	0.2	%
		LM1086-1.8 I _{OUT} = 0mA, 3.3V ≤ V _{IN} ≤ 18V		0.3	6	mV
			0.6	6	mV	
	LM1086-2.5 I _{OUT} = 0mA, 4.0V ≤ V _{IN} ≤ 18V		0.3	6	mV	
			0.6	6	mV	

Electrical Characteristics (Continued)

Typicals and limits appearing in normal type apply for $T_J = 25^\circ\text{C}$. Limits appearing in **Boldface** type apply over the entire junction temperature range for operation.

Symbol	Parameter	Conditions	Min (Note 6)	Typ (Note 5)	Max (Note 6)	Units
		LM1086-2.85 $I_{OUT} = 0\text{mA}$, $4.35\text{V} \leq V_{IN} \leq 18\text{V}$		0.3 0.6	6 6	mV mV
		LM1086-3.3 $I_{OUT} = 0\text{mA}$, $4.5\text{V} \leq V_{IN} \leq 18\text{V}$		0.5 1.0	10 10	mV mV
		LM1086-3.45 $I_{OUT} = 0\text{mA}$, $4.95\text{V} \leq V_{IN} \leq 18\text{V}$		0.5 1.0	10 10	mV mV
		LM1086-5.0 $I_{OUT} = 0\text{mA}$, $6.5\text{V} \leq V_{IN} \leq 20\text{V}$		0.5 1.0	10 10	mV mV
ΔV_{OUT}	Load Regulation (Note 8)	LM1086-ADJ $(V_{IN} - V_{OUT}) = 3\text{V}$, $10\text{mA} \leq I_{OUT} \leq I_{FULL\ LOAD}$		0.1 0.2	0.3 0.4	% %
		LM1086-1.8, 2.5, 2.85 $V_{IN} = 5\text{V}$, $0 \leq I_{OUT} \leq I_{FULL\ LOAD}$		3 6	12 20	mV mV
		LM1086-3.3, 3.45 $V_{IN} = 5\text{V}$, $0 \leq I_{OUT} \leq I_{FULL\ LOAD}$		3 7	15 25	mV mV
		LM1086-5.0 $V_{IN} = 8\text{V}$, $0 \leq I_{OUT} \leq I_{FULL\ LOAD}$		5 10	20 35	mV mV
		Dropout Voltage (Note 9)	LM1086-ADJ, 1.8, 2.5, 2.85, 3.3, 3.45, 5 ΔV_{REF} , $\Delta V_{OUT} = 1\%$, $I_{OUT} = 1.5\text{A}$		1.3	1.5
I_{LIMIT}	Current Limit	LM1086-ADJ $V_{IN} - V_{OUT} = 5\text{V}$ $V_{IN} - V_{OUT} = 25\text{V}$	1.50 0.05	2.7 0.15		A A
		LM1086-1.8, 2.5, 2.85, 3.3, 3.45, $V_{IN} = 8\text{V}$	1.5	2.7		A
		LM1086-5.0, $V_{IN} = 10\text{V}$	1.5	2.7		A
		Minimum Load Current (Note 10)	LM1086-ADJ $V_{IN} - V_{OUT} = 25\text{V}$		5.0	10.0
	Quiescent Current	LM1086-1.8, 2.5, 2.85, $V_{IN} \leq 18\text{V}$		5.0	10.0	mA
		LM1086-3.3, $V_{IN} \leq 18\text{V}$		5.0	10.0	mA
		LM1086-3.45, $V_{IN} \leq 18\text{V}$		5.0	10.0	mA
		LM1086-5.0, $V_{IN} \leq 20\text{V}$		5.0	10.0	mA
	Thermal Regulation	$T_A = 25^\circ\text{C}$, 30ms Pulse		0.008	0.04	%/W
	Ripple Rejection	$f_{RIPPLE} = 120\text{Hz}$, $C_{OUT} = 25\mu\text{F}$ Tantalum, $I_{OUT} = 1.5\text{A}$				
		LM1086-ADJ, $C_{ADJ} = 25\mu\text{F}$, $(V_{IN} - V_O) = 3\text{V}$	60	75		dB
		LM1086-1.8, 2.5, 2.85, $V_{IN} = 6\text{V}$	60	72		dB
		LM1086-3.3, $V_{IN} = 6.3\text{V}$	60	72		dB
		LM1086-3.45, $V_{IN} = 6.3\text{V}$	60	72		dB
		LM1086-5.0, $V_{IN} = 8\text{V}$	60	68		dB
	Adjust Pin Current	LM1086		55	120	μA
	Adjust Pin Current Change	$10\text{mA} \leq I_{OUT} \leq I_{FULL\ LOAD}$, $1.5\text{V} \leq (V_{IN} - V_{OUT}) \leq 15\text{V}$		0.2	5	μA
	Temperature Stability			0.5		%
	Long Term Stability	$T_A = 125^\circ\text{C}$, 1000Hrs		0.3	1.0	%
	RMS Noise (% of V_{OUT})	$10\text{Hz} \leq f \leq 10\text{kHz}$		0.003		%
θ_{JC}	Thermal Resistance Junction-to-Case	3-Lead TO-263: Control Section/Output Section			1.5/4.0	$^\circ\text{C/W}$
		3-Lead TO-220: Control Section/Output Section			1.5/4.0	$^\circ\text{C/W}$

Physical Dimensions inches (millimeters) unless otherwise noted

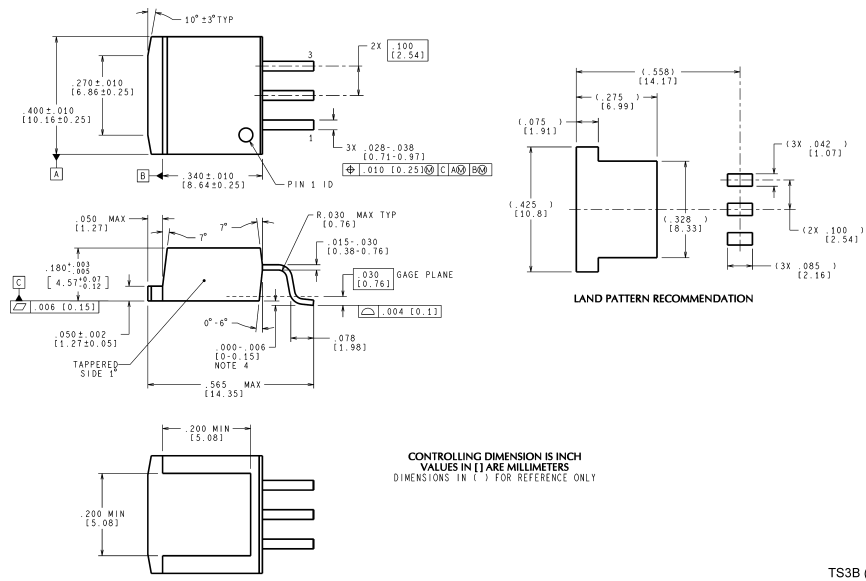

**3-Lead TO-263
NS Package Number TS3B**

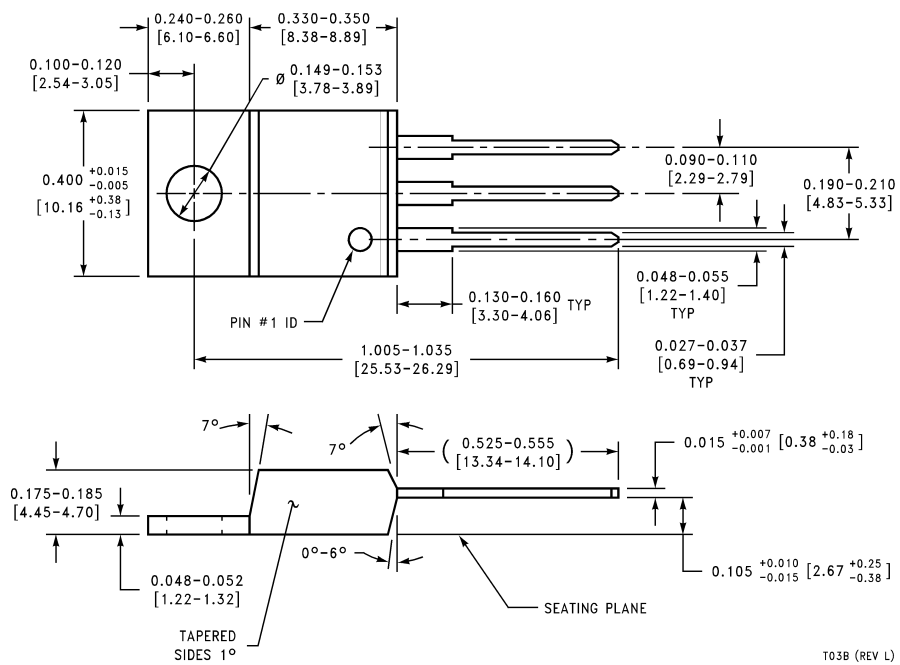

**3-Lead TO-220
NS Package Number T03B**