

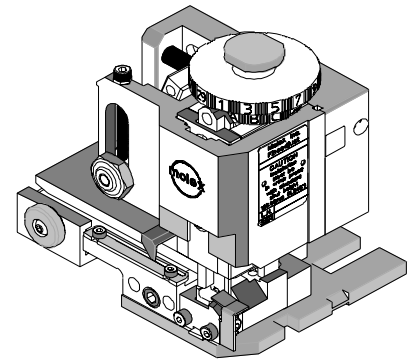

FineAdjust Applicator Specification Sheet Part No. 63860-7000



FEATURES

- Directly adapts to most automatic wire processing machines
- Quick punch removal with the push of a button for fast and easy tooling change
- Applicator designed to industry standard mounting and shut height 135.80mm (5.346")
- Quick set-up time; plus the crimp height, track and feed adjustments can be set without removing the applicator from the press
- Fine adjustment allows users to achieve target with little effort by adjusting in increments of 0.15mm (.0006") for conductor crimp height and .063mm (.0025") for insulation height
- Independent adjustment rings allow users to quickly adjust the conductor or insulation crimp height without affecting each other

SCOPE

Terminal Series No.	Wire Size		Insulation Diameter		Strip Length	
	AWG	mm ²	mm	In.	mm	In.
50058-8000	28-32	0.08-0.03	0.50-1.00	.020-.039	1.40-1.90	.055-.075
50079-8000	26-28	0.12-0.08	0.50-1.00	.020-.039	1.40-1.90	.055-.075

DEFINITION OF TERMS

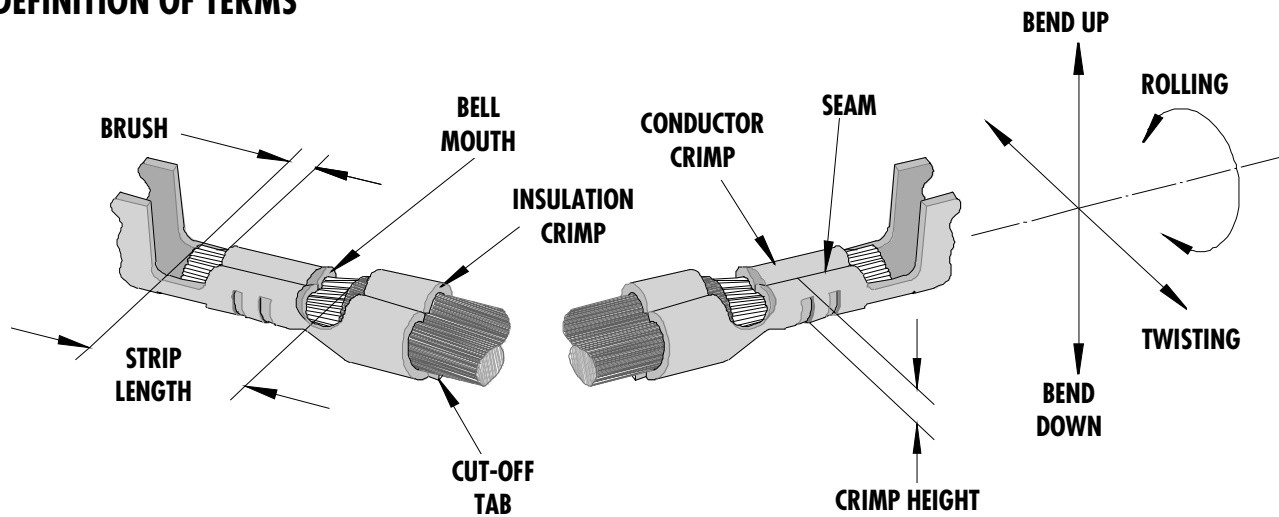

The above terminal drawing is a generic terminal representation. It is not an image of a terminal listed in the scope.

INSULATION CRIMP FORM

This crimp terminal is designed for miniaturization; therefore, each dimension of insulation crimp portion appears small as compared to the terminal material thickness. In order to avoid insulation piercing the crimp forms by the insulation barrel, coining is provided inside of the insulation barrel. For this reason, various crimp forms will occur at the tip of the insulation crimp barrel shown in the figure below.

These crimp forms maybe changed completely by a small change in the wire, insulation punch, or terminal.

These crimp forms are satisfactory for original function of the insulation crimp portion and it is confirmed that all of these forms below are acceptable insulation crimps.

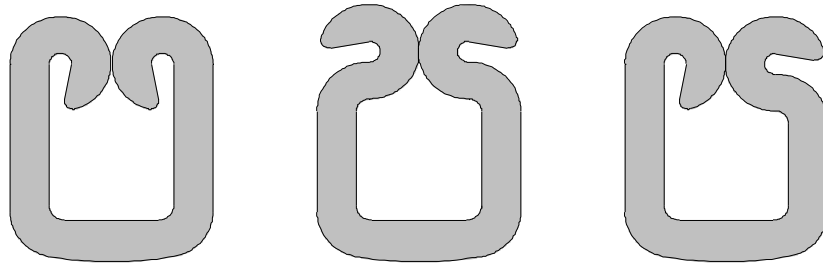

CRIMP SPECIFICATION

Terminal Series No.	Bell mouth		Cut-off Tab Max.		Conductor Brush	
	mm	In.	mm	In.	mm	In.
50058-8000	0.00	.000	0.15	.006	0.00-0.70	.000-.028
50079-8000	0.00	.000	0.15	.006	0.00-0.70	.000-.028

Terminal Series No.	Bend up	Bend down	Twist	Roll	Punch Width mm (Ref)				Seam Seam shall not be open and no wire allowed out of the crimping area
	Degree		Degree		Conductor		Insulation		
	mm	In	mm	In	mm	In	mm	In	
50058-8000	5	4	6	8	0.80	.031	0.85	.033	
50079-8000	5	4	6	8	0.80	.031	0.85	.033	

After crimping, the conductor profile should measure the following.

Terminal Series No.	Wire Size		Crimp Height		Pull Force Min.	
	AWG	mm ²	mm	In.	N	Lb.
50058-8000	28	0.80	0.51-0.56	.020-.022	9.8	2.2
50058-8000	30	0.05	0.48-0.53	.019-.021	4.9	1.1
50058-8000	32	0.03	0.46-0.51	.018-.020	2.9	0.7
50079-8000	26	0.12	0.60-0.65	.023-.025	9.8	2.2
50079-8000	28	0.08	0.56-0.61	.022-.024	9.8	2.2

Pull Force should be measured with no influence from the insulation crimp.

The above specifications are guidelines to an optimum crimp.

PARTS LIST

Item	Order No	Engineering No.	Description	Quantity
	63860-7000	63860-7000	FineAdjust Applicator (Fig. 1)	REF
1	63444-0805	63444-0805	Conductor Punch	1 Y
2	63445-0821	63445-0821	Combination Anvil	1 Y
3	63454-0031	63454-0031	Insulation Punch	1 Y
4	63443-0003	63443-0003	Cut-Off Plunger	1 Y
5	63443-0012	63443-0012	Front Plunger Retainer	1 Y
6	11-24-1067	4996-4	Cut-off Plunger Spring	1
7	11-40-4039	8302-5	Front Plunger Striker	1
8	63443-0021	63443-0021	Lower Tooling Key	1
9	63443-6003	63443-6003	Rear Cover	1
10	11-18-4083	60707-8	Front Cover	1
11	63443-2402	63443-2402	Anvil Mount	1
12	63443-4025	63443-4025	Wire Stop	1
13	63443-0009	63443-0009	Scrape Chute	1
14	63800-4900	63800-4900	Fine Adjust Applicator Frame	1
15	N/A	N/A	M3 by 6Lg. SHCS	2**
16	N/A	N/A	M4 by 6Lg. SHCS	1**
17	N/A	N/A	M4 by 10Lg. BHCS	3**
18	N/A	N/A	M4 by 20Lg. SHCS	1**
19	N/A	N/A	M4 by 50Lg. SHCS	1**
20	N/A	N/A	3MM by 6Lg. Roll Pin	1**
21	N/A	N/A	#10-32 by 1/4"Lg. BHCS	1**
22	63860-7070	63860-7070	Tool Kit (All Y Items)	REF

** The following purchased parts are available from an Industrial supply company such as MSC (1-800-645-7270).

Assembly Drawing

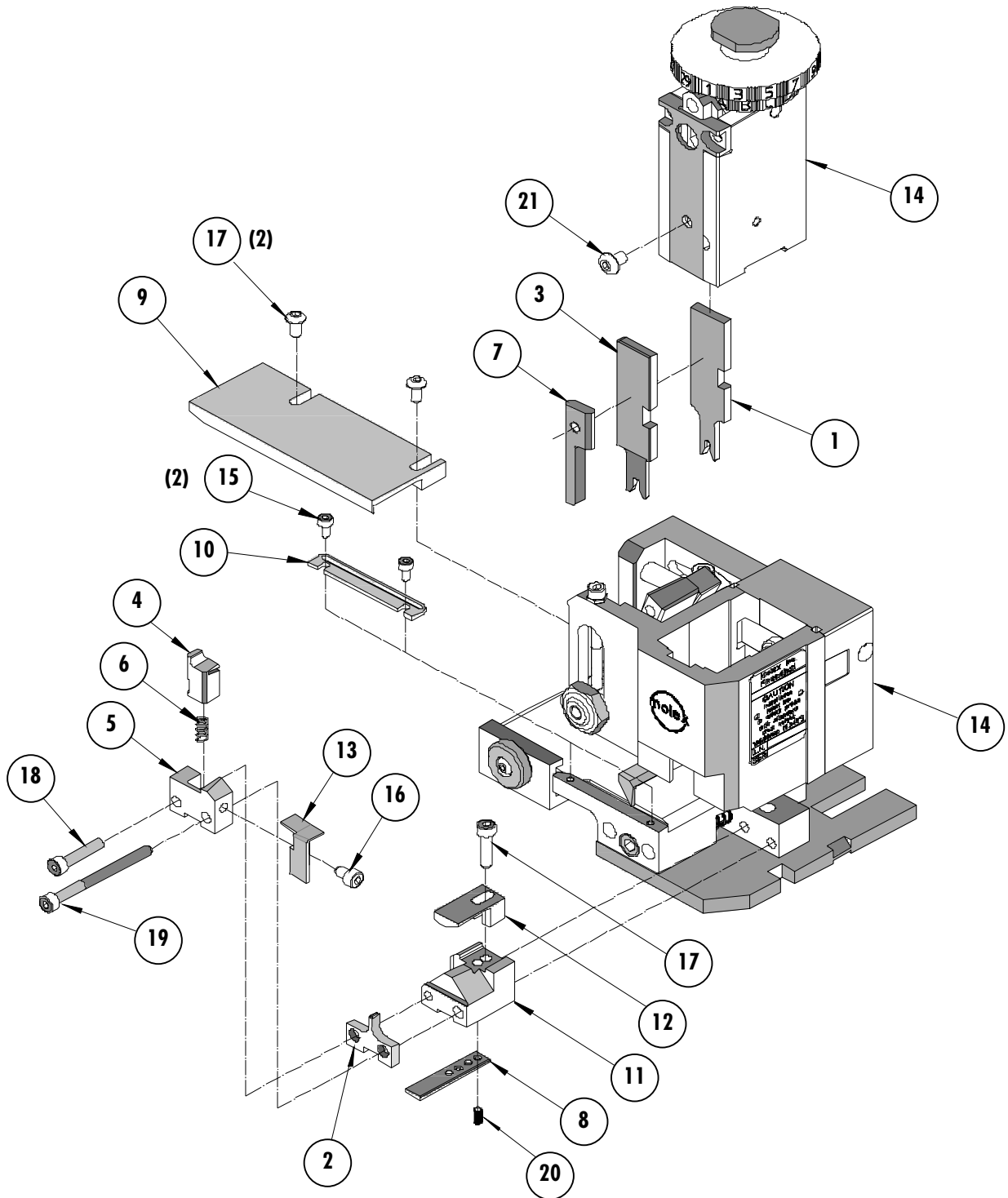

Figure 1

NOTES

1. Molex recommends an extra perishable tooling kit be maintained at your facility.
2. Verify tooling alignment by manually cycling the press and Applicator before crimping under power. Check that all screws are tight.
3. Slugs, Terminals, Dirt and Oil should be kept clear of work area.
4. Wear safety glasses at all times.
5. For recommended maintenance, refer to the FineAdjust Manual.

CAUTION: This applicator should only be used in a press with a shut height of 135.8mm (5.346"). Tooling damage could result at a lower setting.

CAUTION: To prevent injury never operate this Applicator without the guards supplied with the press or wire-processing machine in place. Reference the press or wire processing manufacturer's instruction manual.

CAUTION: Molex crimp specifications are valid only when used with Molex terminals, applicators and tooling.

Molex Application Tooling Group

1150 E. Diehl Road
Naperville, IL 60563
Tel: (630) 969-4550
Fax: (630) 505-0049

Visit our Web site at <http://www.molex.com>