



BU806
BU807

MEDIUM VOLTAGE NPN FAST SWITCHING DARLINGTON TRANSISTORS

- STMicroelectronics PREFERRED SALESTYPES
- NPN DARLINGTONS
- LOW BASE-DRIVE REQUIREMENTS
- INTEGRATED ANTIPARALLEL COLLECTOR-EMITTER DIODE

APPLICATION

- HORIZONTAL DEFLECTION FOR MONOCHROME TVs

DESCRIPTION

The devices are silicon Epitaxial Planar NPN power transistors in Darlington configuration with integrated base-emitter speed-up diode, mounted in TO-220 plastic package.

They can be used in horizontal output stages of 110 °CRT video displays.

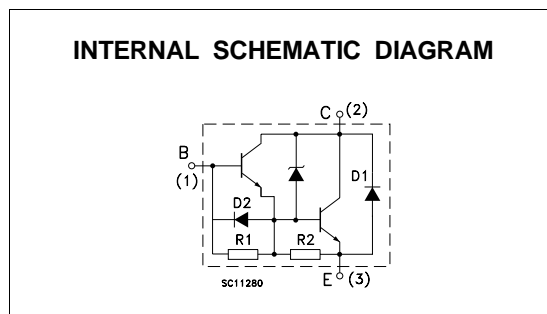
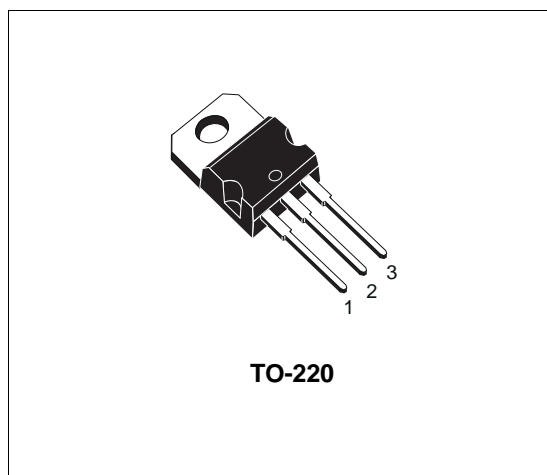

ABSOLUTE MAXIMUM RATINGS

Symbol	Parameter	Value		Unit
		BU806	BU807	
V_{CBO}	Collector-base Voltage ($I_E = 0$)	400	330	V
V_{CEV}	Collector-emitter Voltage ($V_{BE} = -6V$)	400	330	V
V_{CEO}	Collector-emitter Voltage ($I_B = 0$)	200	150	V
V_{EBO}	Emitter-Base Voltage ($I_C = 0$)	6		V
I_C	Collector Current	8		A
I_{CM}	Collector Peak Current	15		A
I_{DM}	Damper Diode Peak Forward Current	10		A
I_B	Base Current	2		A
P_{tot}	Total Power Dissipation at $T_{case} < 25\text{ °C}$	60		W
T_{stg}	Storage Temperature	-65 to 150		°C
T_j	Max Operating Junction Temperature	150		°C

BU806 / BU807

THERMAL DATA

R _{thj-case}	Thermal Resistance Junction-case	Max	2.08	°C/W
R _{thj-amb}	Thermal Resistance Junction-ambient	Max	70	°C/W

ELECTRICAL CHARACTERISTICS (T_{case} = 25 °C unless otherwise specified)

Symbol	Parameter	Test Conditions	Min.	Typ.	Max.	Unit
I _{CEs}	Collector Cut-off Current (V _{BE} = 0)	for BU807 for BU806 V _{CE} = 330 V V _{CE} = 400 V			100 100	μA μA
I _{CEV}	Collector Cut-off Current (V _{BE} = -6V)	for BU807 for BU806 V _{CE} = 330 V V _{CE} = 400 V			100 100	μA μA
I _{EBO}	Emitter Cut-off Current (I _C = 0)	V _{EB} = 6 V			3.5	mA
V _{CEO(sus)*}	Collector-Emitter Sustaining Voltage (I _B = 0)	I _C = 100 mA for BU807 for BU806	150 200			V V
V _{CE(sat)*}	Collector-Emitter Saturation Voltage	I _C = 5A I _B = 50mA			1.5	V
V _{BE(sat)*}	Base-Emitter Saturation Voltage	I _C = 5A I _B = 50mA			2.4	V
V _{F*}	Damper Diode Forward Voltage	I _F = 4A			2	V
t _{on} t _{off} t _s t _f	RESISTIVE LOAD Turn-on Time Turn-off Time Storage Time Fall Time	I _C = 5 A I _{B1} = 50 mA V _{CC} = 100 V I _{B2} = -500 mA		0.35 0.4 0.55 0.2	1	μs μs μs μs

* Pulsed: Pulse duration = 300 μs, duty cycle < 1.5 %

TO-220 MECHANICAL DATA

DIM.	mm			inch		
	MIN.	TYP.	MAX.	MIN.	TYP.	MAX.
A	4.40		4.60	0.173		0.181
C	1.23		1.32	0.048		0.052
D	2.40		2.72	0.094		0.107
E	0.49		0.70	0.019		0.027
F	0.61		0.88	0.024		0.034
F1	1.14		1.70	0.044		0.067
F2	1.14		1.70	0.044		0.067
G	4.95		5.15	0.194		0.202
G1	2.40		2.70	0.094		0.106
H2	10.00		10.40	0.394		0.409
L2		16.40			0.645	
L4	13.00		14.00	0.511		0.551
L5	2.65		2.95	0.104		0.116
L6	15.25		15.75	0.600		0.620
L7	6.20		6.60	0.244		0.260
L9	3.50		3.93	0.137		0.154
M		2.60			0.102	
DIA.	3.75		3.85	0.147		0.151

