

HFCT-5701L/LP

Single Mode Laser Small Form Factor Pluggable (SFP) Transceivers
for 1.25 GBd Ethernet and 1.0625 GBd Fibre Channel Applications



Data Sheet

Description

The HFCT-5701L/LP Small Form Factor Pluggable LC optical transceiver is compliant with both the IEEE 802.3Z (1000BASE-LX) and Fiber Channel 100-SM-LC-L, also it complies to Small Form Factor Pluggable (SFP) Multi-Source Agreement (MSA) specifications. The transceiver is intended for premise, public and access networking equipment. The product transmits data over single mode cable for a link distance of 10 km, which is in excess of the standard.

The transmitter section incorporates a 1300 nm Fabry Perot (FP) laser. The transmitter has full IEC 825 and CDRH Class 1 eye safety.

Related Products

- HFBR-5701L/LP: 850 nm 1.25 GBd 3.3 V multimode SFP Gigabit Ethernet transceiver
- HDMP-1687: Quad Channel SerDes IC 1.25 GBd Ethernet
- HDMP-1646A: Single Channel SerDes IC for 1.25 GBd Ethernet and 1.0625 GBd Fibre Channel

Features

- IEEE 802.3Z Gigabit Ethernet (1.25 GBd) 1000BASE-LX compliant
- Compliant with ANSI Fiber Channel Physical Interfaces (FC-PI Rev 13)
- Small Form Factor Pluggable (SFP) Multi-Source Agreement (MSA) compliant
- Manufactured in an ISO 9001 "compliant facility"
- Hot-pluggable
- HFCT-5701LP bail wire delatch
HFCT-5701L standard delatch
- +3.3 V dc power supply
- 1310 nm longwave laser
- Eye safety certified:
 - US 21 CFR(J)
 - IEC 60825-1 (+All)
- LC-Duplex fiber connector compatible
- Fiber compatibility:
 - 2 m to 10 km with 9 μ m SM fiber
 - 2 m to 550 m with 62.5 μ m MM fiber

Applications

- Switch to switch applications
- Switched backplane applications
- High Speed Interface for server farms
- Metro access switch GbE connections

General Features

The receiver section for the HFCT-5701L/LP contains an InGaAs/InP photo detector and a preamplifier mounted in an optical subassembly. This optical subassembly is coupled to a post amplifier/decision circuit on a circuit board. The design of the optical subassembly is such that it provides better than 12 dB Optical Return Loss (ORL).

The HFCT-5701L/LP is compliant to 1 GbE and 1G FC specifications. This includes specifications for the signal coding, optical fiber and connector types, optical and electrical transmitter characteristics, optical and electrical receiver characteristics, jitter characteristics, and compliance testing methodology for the aforementioned.

This transceiver is capable of implementing both Single Mode (SM) and Multimode (MM) optical fiber applications in that order of precedence in the event of conflicting specifications. In addition, the SM link type exceeds the 2 m to 5 km 1000BASE-LX specification by achieving compliance over 2 m to 10 km. The MM link type is expected to meet the 62.5 μm MMF specification when used with an "offset launch" fiber.

The optical connector is LC duplex.

SFP MSA Compliance

The product package is compliant with the SFP MSA with the LC connector option. The SFP MSA includes specifications for mechanical packaging and performance as well as dc, ac and control signal timing and performance.

The power supply is 3.3 V dc.

The High Speed I/O (HSIO) signal interface is a Low Voltage Differential type. It is ac coupled and terminated internally to the module. The internal termination is a 100 Ohm differential load.

Operating Temperature

The HFCT-5701L/LP has an operating case temperature of -10 to +85 °C .

Serial Identification (EEPROM)

The HFCT-5701L/LP is compliant with the SFP MSA, which defines the serial identification protocol. This protocol uses the 2-wire serial CMOS E2PROM protocol of the ATMEL AT24C01A or similar. MSA compliant, example contents of the HFCT-5701L/LP serial ID memory are defined in Table 3.

Eye Safety

For details of product compliance, see Table 1.

Delatch Mechanism

The delatching mechanism uses the same design as the MM HFBR-5701L. The HFCT-5701L/LP is designed with an MSA complaint standard delatch as well as an optional bail wire delatch. The bail wire delatch has been slightly modified outside MSA compliance to optimize the mechanical performance of the product. These modifications do not interfere with the overall form, fit and function as specified by the SFP MSA.

Power Supply Noise

The HFCT-5701L/LP can withstand an injection of PSN on the V_{CC} lines of 100 mV ac without a degradation in eye mask margin to 10% on the transmitter and a 1 dB sensitivity penalty on the receiver. This occurs when the product is used in conjunction with the MSA recommended power supply filter shown in Figure 1.

Regulatory Compliance

The product meets all of the regulatory compliance listed in Table 1.

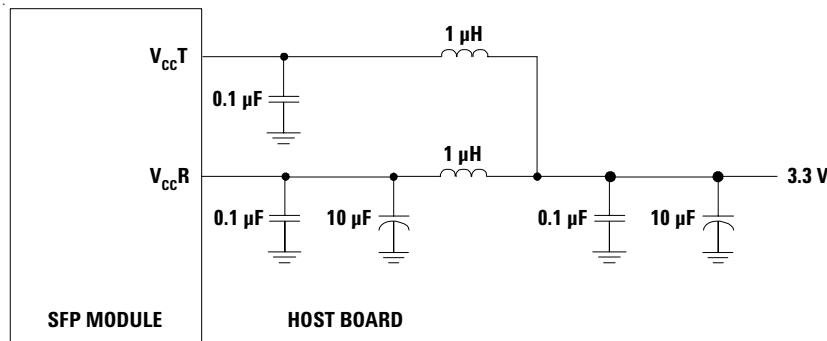

Figure 1 - MSA required power supply filter

Table 1 - Regulatory Compliance

Feature	Test Method	Performance
Electrostatic Discharge (ESD) to the Electrical Pins	MIL-STD-883C Method 3015	Class 2 (>2000 Volts)
Electrostatic Discharge (ESD) to the Duplex LC Receptacle	Bellcore GR1089-CORE	25 kV Air Discharge 10 Zaps at 8 kV (contact discharge) on the electrical faceplate on panel.
Electromagnetic Interference (EMI)	FCC Class B	Applications with high SFP port counts are expected to be compliant; however, margins are dependent on customer board and chassis design.
Immunity	Variation of IEC 61000-4-3	No measurable effect from a 10 V/m field swept from 80 to 1000 MHz applied to the transceiver without a chassis enclosure.
Eye Safety	US FDA CDRH AEL Class 1 EN (IEC) 60825-1, 2, EN60950 Class 1	CDRH certification # 9521220-52 TUV file # 933/510206/02 UL file # E173874
Component Recognition	Underwriter's Laboratories and Canadian Standards Association Joint Component Recognition for Information Technology Equipment Including Electrical Business Equipment	UL file # E173874

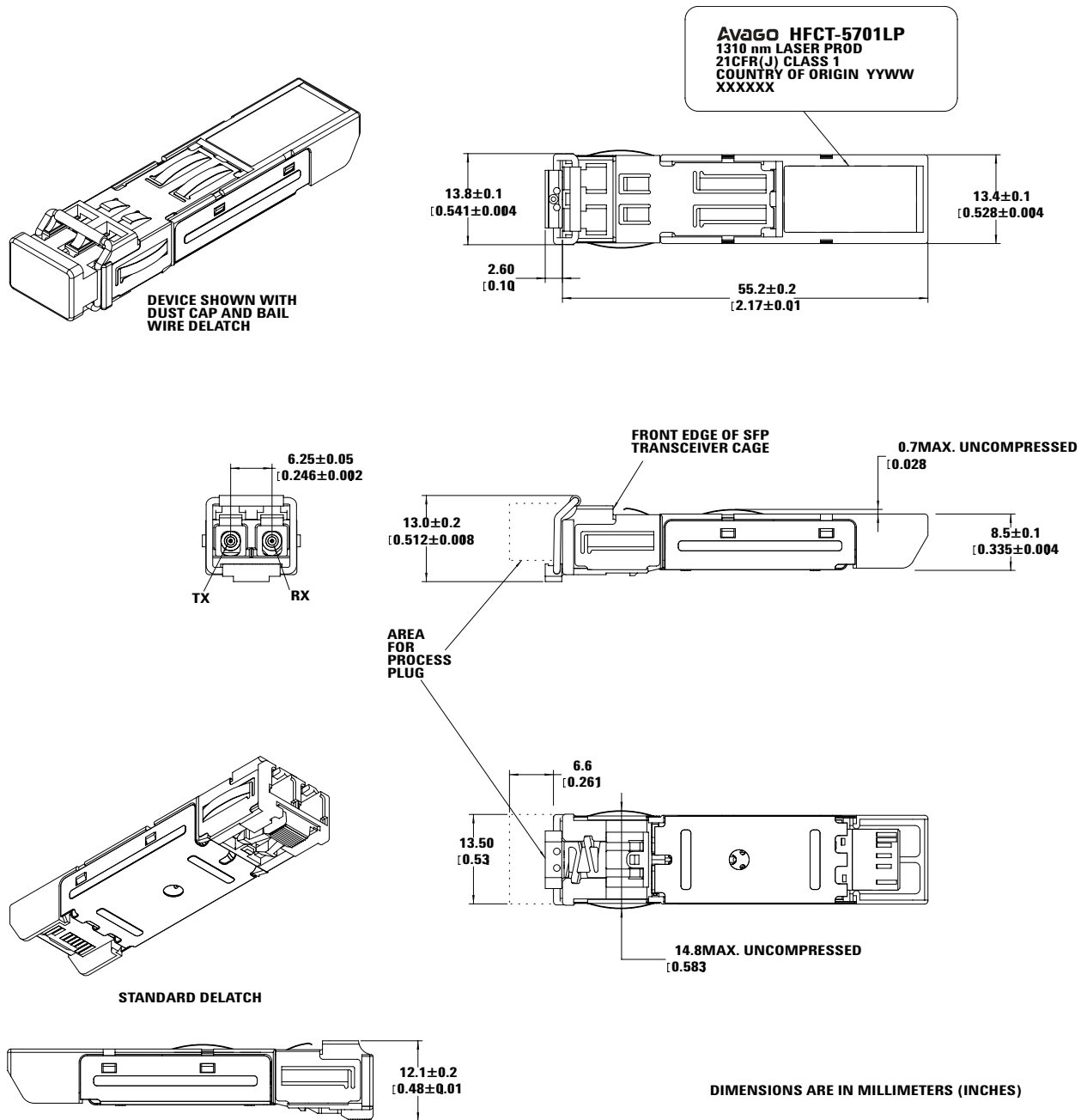

Figure 2a. Drawing of SFP Transceiver

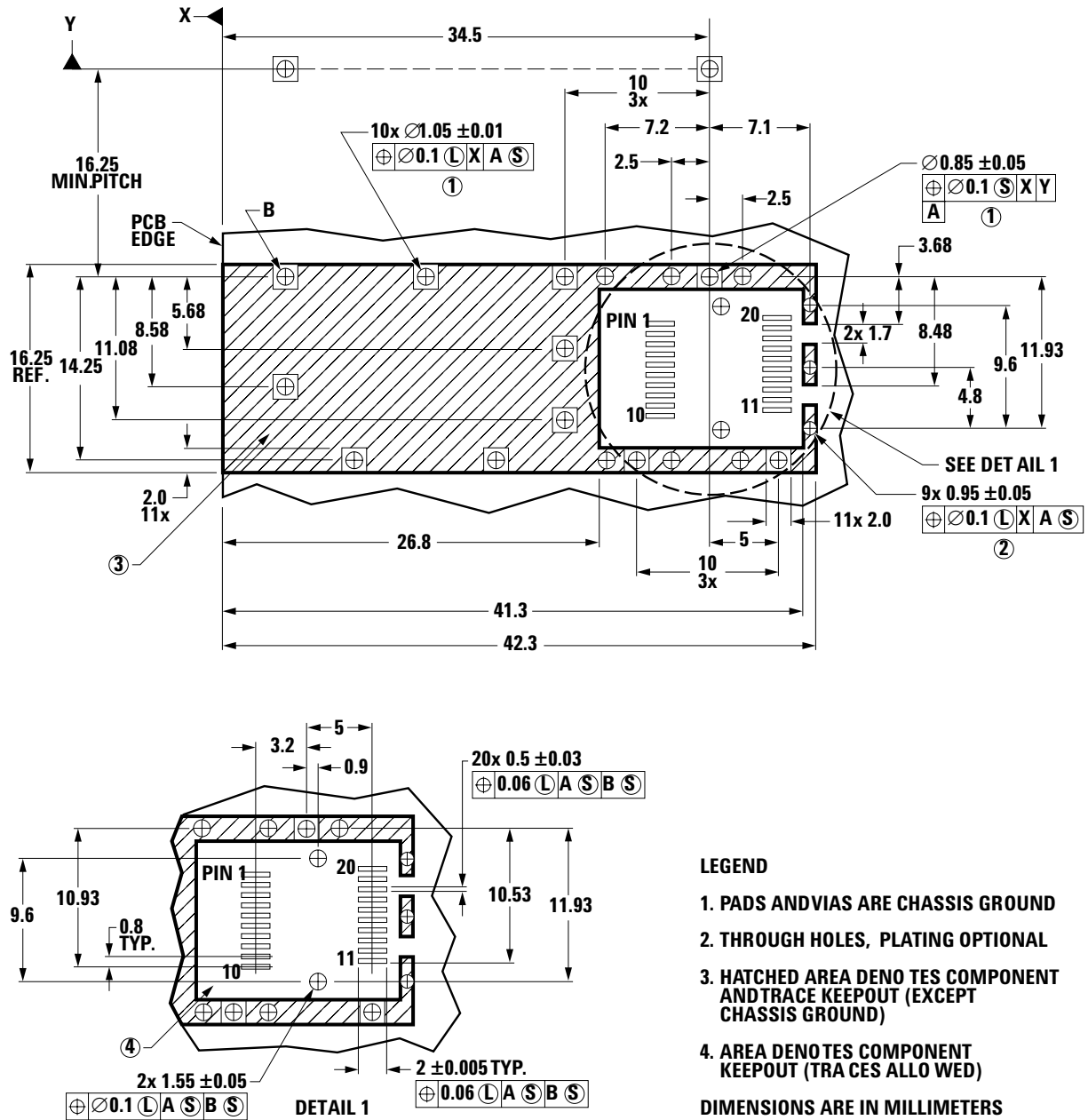
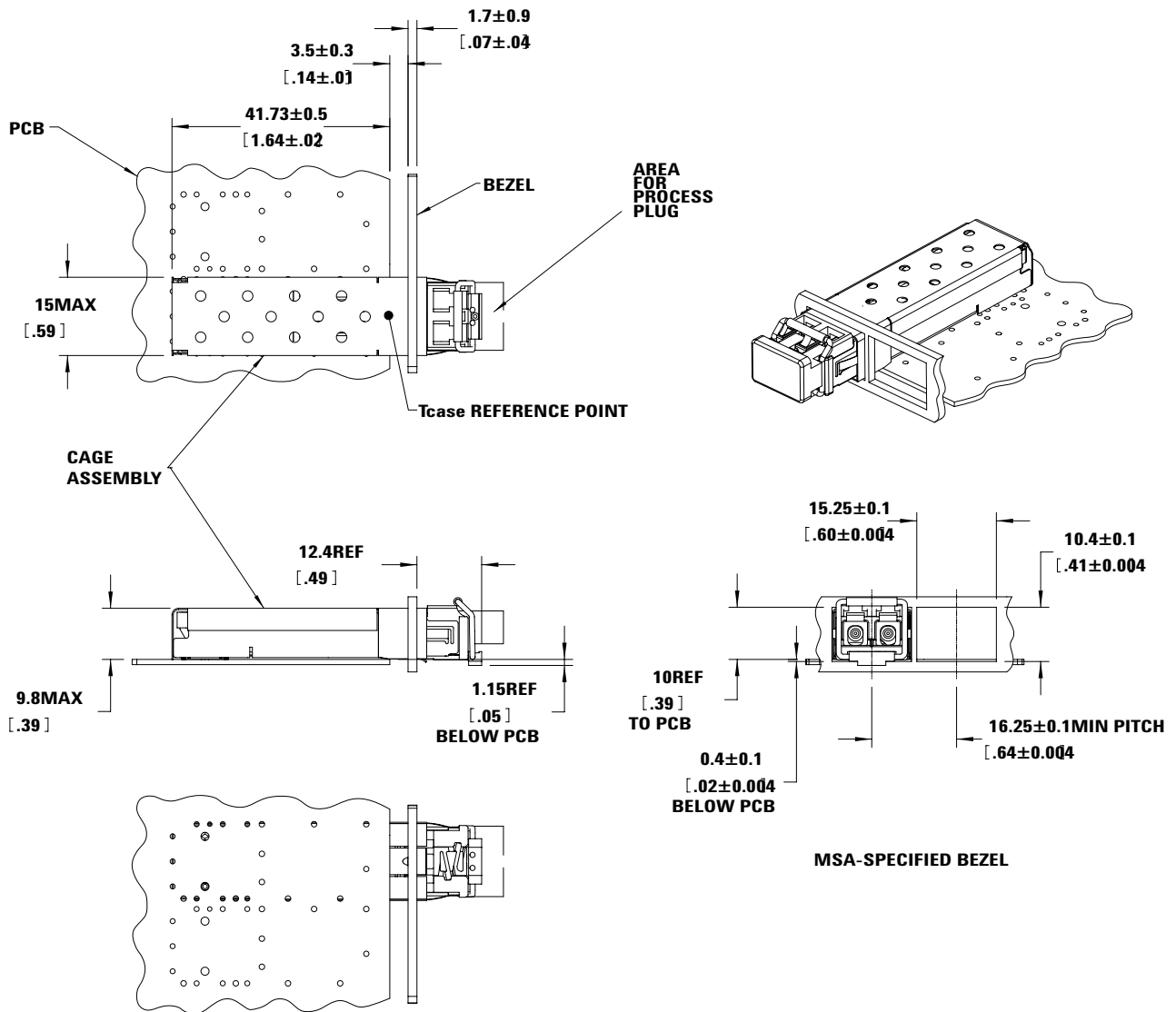

Figure 2b. SFP host board mechanical layout



DIMENSIONS ARE IN MILLIMETERS [INCHES].

Figure 2c.

Pin-out Table

The pin arrangement and definition of this product meets SFP MSA. Table 2 lists the pin description.

Table 2 - Pin description

Pin	Name	Function/Description	MSA Notes
1	VeeT	Transmitter Ground	
2	TX Fault	Transmitter Fault Indication	Note 1
3	TX Disable	Transmitter Disable - Module disables on high or open	Note 2
4	MOD-DEF2	Module Definition 2 - Two wire serial ID interface	Note 3
5	MOD-DEF1	Module Definition 1 - Two wire serial ID interface	Note 3
6	MOD-DEF0	Module Definition 0 - Grounded in module	Note 3
7	Rate Select	Not Connected	
8	LOS	Loss of Signal	Note 4
9	VeeR	Receiver Ground	
10	VeeR	Receiver Ground	
11	VeeR	Receiver Ground	
12	RD-	Inverse Received Data Out	Note 5
13	RD+	Received Data Out	Note 5
14	VeeR	Receiver Ground	
15	VccR	Receiver Power - 3.3 V \pm 5%	Note 6
16	VccT	Transmitter Power - 3.3 V \pm 5%	Note 6
17	VeeT	Transmitter Ground	
18	TD+	Transmitter Data In	Note 7
19	TD-	Inverse Transmitter Data In	Note 7
20	VeeT	Transmitter Ground	

Notes:

- TX Fault is an open collector/drain output, which should be pulled up with a 4.7K – 10K resistor on the host board. Pull up voltage between 2.0 V and VccT, R+0.3 V. When high, output indicates a laser fault of some kind. Low indicates normal operation. In the low state, the output will be pulled to < 0.8 V
- TX Disable input is used to shut down the laser output per the state table below with an external 4.7 - 10 K Ω pull-up resistor.

Low (0 - 0.8 V):	Transmitter on
Between (0.8 V and 2.0 V):	Undefined
High (2.0 - 3.465 V):	Transmitter Disabled
Open:	Transmitter Disabled
- MOD-DEF 0,1,2. These are the module definition pins. They should be pulled up with a 4.7 - 10 K Ω resistor on the host board to a supply less than VccT +0.3 V or VccR+0.3 V.
 - MOD-DEF 0 is grounded by the module to indicate that the module is present
 - MOD-DEF 1 is clock line of two wire serial interface for optional serial ID
 - MOD-DEF 2 is data line of two wire serial interface for optional serial ID
- LOS (Loss of Signal) is an open collector/drain output which should be pulled up externally with a 4.7K - 10 K Ω resistor on the host board to a supply < VccT,R+0.3 V. When high, this output indicates the received optical power is below the worst case receiver sensitivity (as defined by the standard in use). Low indicates normal operation. In the low state, the output will be pulled to < 0.8 V.
- RD-/+ : These are the differential receiver outputs. They are ac coupled 100 Ω differential lines which should be terminated with 100 Ω differential at the user SERDES. The ac coupling is done inside the module and is thus not required on the host board. The voltage swing on these lines will be between 370 and 1600 mV differential (185 - 800 mV single ended) when properly terminated.
- VccR and VccT are the receiver and transmitter power supplies. They are defined as 3.135 - 3.465 V at the SFP connector pin. The maximum supply current is 300 mA and the associated inrush current will be no more than 30 mA above steady state after 500 nanoseconds.
- TD-/+ : These are the differential transmitter inputs. They are ac coupled differential lines with 100 Ω differential termination inside the module. The ac coupling is done inside the module and is thus not required on the host board. The inputs will accept differential swings of 500 - 2400 mV (250 - 1000 mV single ended), though it is recommended that values between 500 and 1200 mV differential (250 - 600 mV single ended) be used for best EMI performance.

Absolute Maximum Ratings

Absolute maximum ratings are those values beyond which functional performance is not intended, device reliability is not implied, and damage to the device may occur.

Parameter	Symbol	Minimum	Maximum	Unit	Notes
Storage Temperature (non-operating)	T_s	-40	+85	° C	
Relative Humidity	RH	5	85	%	
Supply Voltage	V_{cc}	-0.5	3.63	V	
Input Voltage on any Pin	V_i	-0.5	V_{cc}	V	

Recommended Operating Conditions

Typical operating conditions are those values for which functional performance and device reliability is implied.

Parameter	Symbol	Minimum	Typical	Maximum	Unit	Notes
Case Operating Temperature	T_c	-10		+85	° C	
Supply Voltage	V_{cc}	3.14	3.3	3.47	V	

Transceiver Electrical Characteristics

Parameter	Symbol	Minimum	Typical	Maximum	Unit	Notes
Module supply current	I_{cc}		200	240	mA	1
Power Dissipation	P_{DISS}		660	762.3	mW	1

AC Electrical Characteristics

Power Supply Noise Rejection (peak - peak)	PSNR		100		mV	2
Inrush Current				30	mA	3

DC Electrical Characteristics

Sense Outputs:

Transmit Fault (TX_FAULT)	V_{OH}	2.0		$V_{ccT, R+0.3}$	V	4
Loss of Signal (LOS) MOD-DEF2	V_{OL}			0.8	V	

Control Inputs:

Transmitter Disable (TX_DISABLE)	V_{IH}	2.0		V_{cc}	V	4, 5
MOD-DEF1, 2	V_{IL}			0.8	V	

Data Input:

Transmitter Differential Input Voltage (TD+/-)	V_i	500		2000	mV	6
--	-------	-----	--	------	----	---

Data Output:

Receiver Differential Output Voltage (RD+/-)	V_o	370		1600	mV	7
Receiver Data Rise and Fall Times	T_{rf}			400	ps	

Notes:

- Over temperature and Beginning of Life.
- MSA filter is required on host board 10 Hz to 1 MHz. See Figure 1 (Page 2)
- Satisfied after 500 nanoseconds. Within 500 nanoseconds, maximum of current of 2000 mA and energy of 700 nanojoules
- LVTTL, External 4.7 - 10 K Ω Pull-Up Resistor required
- LVTTL, Internal 4.7 - 10 K Ω Pull-Up Resistor required for TX_Disable
- Internally ac coupled and terminated (100 Ohm differential)
- Internally ac coupled and load termination located at the user SerDes

Transmitter Optical Characteristics

Parameter	Symbol	Minimum	Typical	Maximum	Unit	Notes
Output Optical Power (Average)	P _{out}	-9.5		-3	dBm	SMF IEEE 802.3Z
	P _{out}	-9.5		-3	dBm	62.5/125 μm NA = 0.2 IEEE 802.3Z
	P _{out}	-9.5		-3	dBm	62.5/125 μm NA = 0.275 IEEE 802.3Z
Optical Extinction Ratio	EXR	9			dB	IEEE 802.3Z
Optical Modulation Amplitude	OMA	130			μW	
Center Wavelength	λ _c	1270		1355	nm	
Spectral Width - RMS	s		1.4	2.8	nm	Fig 3
Optical Rise/Fall Time	T _{rise/fall}			320	ps	20% - 80% FC-PI rev 13
RIN ₁₂ (OMA), maximum	RIN			-120	dB/Hz	IEEE 802.3Z
Contributed Deterministic Jitter	DJ (1.0625 Gbps)			0.09	UI	8
Contributed Total Jitter	TJ (1.25 Gbps)			0.28	UI	8
	TJ (1.0625 Gbps)			0.284	UI	8

Receiver Optical Characteristics

Parameter	Symbol	Minimum	Typical	Maximum	Unit	Notes
Optical Power	P _{IN}			-3	dBm	IEEE 802.3Z
Receiver Sensitivity	P _{REC}			-20	dBm	At BER of 10 ⁻¹²
Stressed Receiver Sensitivity				-14.4	dBm	IEEE 802.3Z 8
Receiver Electrical 3 dB Upper Cutoff Frequency				1500	MHz	IEEE 802.3Z
Operating Center Wavelength	λ _c	1270		1355	nm	
Contributed Total Jitter	TJ (1.25Gb/s)			0.332	UI	IEEE 802.3Z
Return Loss (minimum)		12			dB	IEEE 802.3Z 9
Loss of Signal - Deasserted (Average)	P _D	-30			dB	
Loss of Signal - Asserted (Average)	P _A			-20	dB	
Loss of Signal - Hysteresis	P _D - P _A	0.5			dB	

Notes:

8. Deterministic jitter (DJ) and total jitter (TJ) values are measured according to the methods defined in ANSI, T11.2/Project 1230/Rev.10, Fibre Channel-Methodologies for Jitter Specifications (MJS).

Transceiver Timing Characteristics

Parameter	Symbol	Minimum	Typical	Maximum	Unit	Notes
Tx Disable Assert Time	t_off			10	μs	9 IEEE 802.3
Tx Disable Negate Time	t_on			1	Ms	10 IEEE 802.3
Time to initialize, including reset of Tx-Fault	t_init			300	Ms	11
Tx Fault Assert Time	t_fault			100	μs	12
Tx Disable to Reset	t_reset	10			μs	13
LOS Assert Time	t_loss_on			100	μs	14
LOS Deassert Time	t_loss_off			100	μs	15
Serial ID Clock Rate	f_serial_clock			100	KHz	

Notes:

9. Time from rising edge of Tx Disable to when the optical output falls below 10% of nominal.
10. Time from falling edge of Tx Disable to when the modulated optical output rises above 90% of nominal.
11. From power on or negation of Tx Fault using Tx Disable.
12. Time from fault to Tx fault on.
13. Time Tx Disable must be held high to reset Tx_fault.
14. Time from LOS state to Rx LOS assert.
15. Time from non-LOS state to RX LOS deassert.

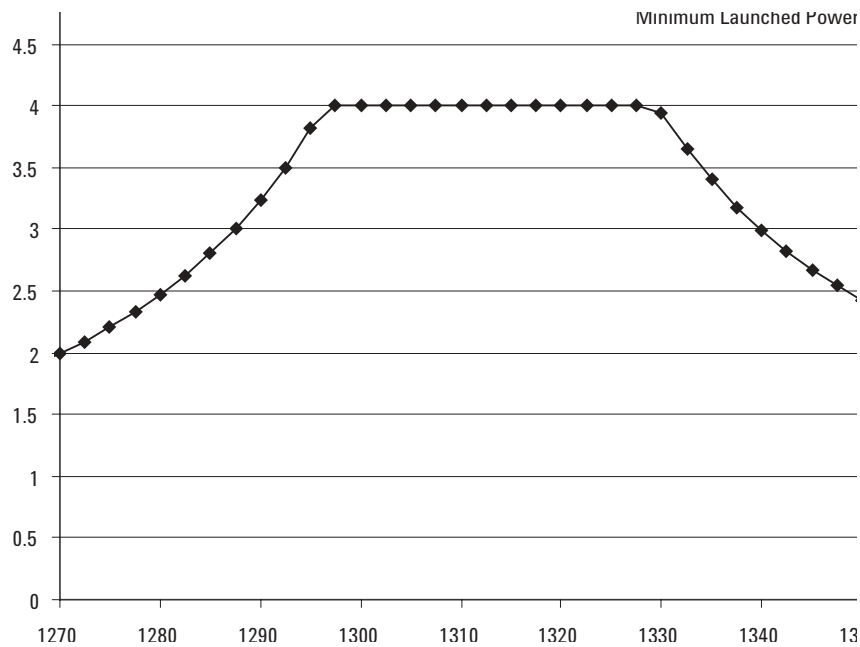

Figure 3. Trade-off curves from FC-PI Rev 13

Note:

In order to meet the link power budget the transmitter can trade off OMA, spectral width and center wavelength as shown in Figure 3.

Table 3. EEPROM Serial ID Memory Contents

Addr	Hex	ASCII	Addr	Hex	ASCII	Addr	Hex	ASCII	Addr	Hex	ASCII
0	03		40	48	H	68	Serial #		96		20
1	04		41	46	F	69	Serial #		97		20
2	07		42	43	C	70	Serial #		98		20
3	00		43	54	T	71	Serial #		99		20
4	00		44	2D	-	72	Serial #		100		20
5	00		45	35	5	73	Serial #		101		20
6	02		46	37	7	74	Serial #		102		20
7	00		47		0	75	Serial #		103		20
8	00		48		1	76	Serial #		104		20
9	00		49	4C	L	77	Serial #		105		20
10	00		50	20		78	Serial #		106		20
11	01		51	20		79	Serial #		107		20
12	0C		52	20		80	Serial #		108		20
13	00		53	20		81	Serial #		109		20
14	0A		54	20		82	Serial #		110		20
15	64		55	20		83	Serial #		111		20
16	32		56	20		84	Datecode		112		20
17	32		57	20		85	Datecode		113		20
18	00		58	20		86	Datecode		114		20
19	00		59	20		87	Datecode		115		20
20	41	A	60	00		88	Datecode		116		20
21	47	G	61	00		89	Datecode		117		20
22	49	I	62	00		90	Datecode		118		20
23	4C	L	63	Checksum		91	Datecode		119		20
24	45	E	64	00		92	0		120		20
25	4E	N	65	1A		93	0		121		20
26	54	T	66	00		94	0		122		20
27	20		67	00		95	Checksum		123		20
28	20								124		20
29	20								125		20
30	20								126		20
31	20								127		20
32	20										
33	20										
34	20										
35	20										
36	00										
37	00										
38	30										
39	D3										

For product information and a complete list of distributors, please go to our web site: www.avagotech.com

Avago, Avago Technologies, and the A logo are trademarks of Avago Technologies, Limited in the United States and other countries.
Data subject to change. Copyright © 2006 Avago Technologies Limited. All rights reserved.
5988-8705EN - December 4, 2006

